



Research Institute Davos

ARI Activity Report 2019



Contents

1	Introduction	4
2	ARI Purpose / Goals / Outlook.....	5
3	Funding Summary	6
4	Research Structure & Advisory Committees.....	7
4.1	AO Research Institute Davos (ARI) Organigram	7
4.2	AO Foundation R&D Platform	7
4.3	AO Research Institute Davos Advisory Committee.....	8
5	ARI Teams / Personnel	9
5.1	Biomedical Development Program	9
5.2	Preclinical Services	10
5.3	Musculoskeletal Regeneration Program	11
5.4	Musculoskeletal Infection Focus Area	13
5.5	ARI Administrative Services	14
5.6	Operations standard and safety.....	15
6	eCM Journal & eCM periodical	16
6.1	eCM annual conference	18
7	Institutional and Professional Relations	19
8	Good News	23
8.1	A new start up built on ARI Research.....	23
8.2	New extramural funding	23
8.3	New AO Foundation intramural funding (grants beyond ARI retainer)	23
8.4	Awards	24
8.5	ARI new MOU's (Memorandums of Understanding)	28
8.6	New Board Positions	28
8.7	Collaborations	30
8.8	Congress news	35
8.9	Visits of ARI.....	36
8.10	AO Research Institute Davos (ARI) at 60	38
9	AO Research Institute Davos Medical Research Fellows	43
10	Remembering Prof Stephan M Perren	54
11	Project Abstracts by Sponsors	58
11.1	AOCMF.....	58
11.2	AOSpine.....	60
11.3	AOTrauma	62
11.4	AOVET.....	75
11.5	AOTC System	76
11.6	ARI Exploratory Research	80

11.7	OCD Consortium.....	100
11.8	AO Development Incubator	102
11.9	Extramural projects	104
12	Team Members.....	119
13	ARI Patents	126
14	Publications & Presentations	128
14.1	2014-2019 Six-year ARI Key Performance Indicators.....	128
14.2	2019 Published peer reviewed papers (epub & in print)	129
14.3	2018 epub, 2019 in print – counted as published paper in 2018.....	133
14.4	Books / Bookchapters	135
14.5	Theses / Dissertations.....	135
14.6	Abstracts published in journals.....	136
14.7	Abstracts (conference participations)	137
14.8	Presentations (not in conference proceedings).....	146

1 Introduction

The AO Research Institute Davos (ARI), which celebrated its 60th anniversary on June 22nd, 2019, has pioneered a significant number of scientific breakthroughs over this time. These advances ranged from providing – during the AO’s first decade – scientific support that enabled compression fixation and development of the dynamic compression plate (DCP), an implant function that is still the backbone of tissue-friendly internal fracture fixation, to the groundbreaking digitalization-enabled treatments under development today. A short [visual history](#) from 1959 to 2019 has been set up on the ARI web site. Five directors have led the institute’s march to the future of patient care, each bringing a passion for the research so essential to the evolution of evidence-based medicine. ARI is recognized as a global research-leader in the musculoskeletal field.

The passing of the globally acclaimed research scientist and AO founding father Prof Dr med Stephan Perren on Wednesday, November 21, 2019 was a poignant incident of the past year. Globally renowned for his strain theory explaining tissue deformation as a critical mechanical factor that controls bone healing, Perren was director of the ARI from 1967–1996. Lauded as an icon and a visionary, he is equally revered for his commitment to mentoring young researchers. An [obituary](#) has been written from many who knew him. This came as a surprise, as we were working with him earlier in the week on a project of his strain theory. [Remembering Prof Stephan M Perren](#) has been published as a web page on the AO site containing many whole-hearted tributes from around the world.

2019 completes a decade as director of the ARI. I am proud that we as a team have focused our research and development having both fundamental research and targeted research for translation and valorization. I am very proud that we have both sold ARI technology to a major orthopaedic company and have helped to valorize our bioprocessing technology, Sound Induced Morphogenesis through a Swiss start up Mimix. These are two major milestones in our new era of valorizing our innovative technologies that we have created and developed to proof of concept. It is highly important to have both areas of research within the ARI, to both extend our knowledge and to create space for innovative solutions to problems faced by the surgeons to help the patient recover faster.

In 2019 ARI has surpassed itself with extramural funding from prestigious Swiss and international funding and AO intramural funding which has led to a growth in projects and students and post docs to work on them. There are many cases of good news from awards, prizes, fellowships, professorships to the launch of a new start-up company MimiX Biotherapeutics exploiting research and technology developed by ARI. In 2019 ARI Autogauge technology and the ARI Xin1 technology including all X-ray based application modules was sold as part of its translation to help patient care. The fracture monitor system was further developed and the system was commenced with an external partner in an agile approach targeting a minimal viable product usable in clinical trials.

I thank the whole ARI team for all their dedication to our purpose and the AO Foundation's mission, that has kept ARI at the peak of research and helped bring this knowledge to our surgeons and operational room personnel to improve patient care.

Sincerely

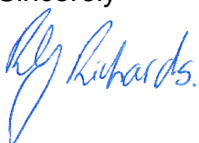

Prof Dr R Geoff Richards FBSE, FIOR,
Director AO Research Institute Davos (ARI)

2 ARI Purpose / Goals / Outlook

Purpose

In its work to further the AO Foundation's mission (promoting excellence in patient care and outcomes in trauma and musculoskeletal disorders), ARI has the purpose to advance patient care through innovative orthopedic R&D.

Orthopedics concerns musculoskeletal, spine and cranio-maxillo-facial trauma, degenerative musculoskeletal diseases, infections, and congenital disorders.

Goals

- Contribute to high quality applied preclinical research and development (exploratory and translational) focused towards clinical applications/solutions.
- Investigate and improve the performance of surgical procedures, devices and substances.
- Foster a close relationship with the AO medical community, academic societies, and universities.
- Provide research environment- / research mentorship / research support for AO clinicians.

Goal Achievements

- Develop productive potential of ARI innovation technology portfolio and create an ARI intellectual property strategy: **Achieved** (ARI Processes used now as standard by AO Foundation, ARI projects evaluated with Canvas model for possible valorization and translation).
- Valorization of Autogauge and Perfect Circle. Acquired over to DPS (who will develop it for the market) **Achieved**
- Launch of a new start-up company MimiX Biotherapeutics to commercialize and exploit ARI developed bioprocessing technology, Sound Induced Morphogenesis (SIM) **Achieved**

Rolling Outlook ARI goals (3 years 2020-2023):

- Development & translation of our unique smart surgery concepts: AO Fracture Monitor
- Establishment of the first European SPF sheep facility (AO Specific Pathogen Free Sheep)
- Strengthen and advance our research activities in patient diagnostics and stratification
- Support Mimix Biotherapeutics in valorization of ARI-based biofabrication technology

Rolling Outlook ARI (next 5 years 2020-2025)

- Maintain our world-class research level and nurture our in-house talents for long-term innovation for AO
- Support AO Clinical Divisions and with cutting edge research and development for their clinical problems
- Develop ARI technology portfolio. Translate and valorize ARI innovations (utilize the new AO Innovation Translation Centre (AO ITC))
- Nurture innovation and further.
- Support AO Clinical Divisions with cutting edge research for their clinical problems (e.g. bone infection models, patient-specific implants).
- Maintain our world-class certifications (ISO, AAALAC, GLP).
- Continue to develop our 3D polymer printing & bioprinting technologies.
- Nurture our scientific networks (e.g. ARI collaborative research consortium).

3 Funding Summary

Income Statement	2018 Actual		2019 Actual	
in CHF '000	abs	%	abs	%
AO Foundation Contribution	9'745	77%	10'519	74%
3rd party Income	2'278	18%	2'295	16%
AO Intercompany	560	4%	1'387	10%
Total Income	12'584	100%	14'201	100%
AOTrauma *	3'821	30%	3'846	28%
AOSpine*	506	4%	752	6%
AOCMF	526	4%	746	5%
AOVET *	53	0%	75	1%
AOTC *	561	4%	596	4%
AO Fundamental Research	2'066	16%	2'166	16%
AO Foundation *	2'863	23%	3'112	23%
3rd party projects	2'278	18%	2'295	17%
Total Expenses	12'674	100%	13'590	100%
Net Result	-90		612	

* incl. AO Intercompany

3rd Party Income' amounted to CHF 2,295 K and was 4% (CHF 92 K) above budget and 1% (CHF 17 K) above previous year. The main reason for the change is a higher number of 3rd party funded grants.

With regards to the split of the 'Total Expenses' by organizational unit, 'Musculoskeletal Regeneration' had the highest share with 41% followed by 'Biomedical Development' and 'Preclinical Services' with 22% and 17% respectively. The overspend versus budget of 'Musculoskeletal Regeneration' amounted to CHF 465 K (+9%) and was mainly caused by higher expenses for R&D material, external services and travel expenses for additional project work fully covered by 3rd party grants. The underspend in 'Management' of CHF 213 K (-20%) versus budget resulted mainly from lower accruals for vacation and flexitime balances of the ARI staff. The variance versus budget in 'Fellowships' (CHF 186 K / 28%) is driven by higher cost for additional fully 3rd party funded Fellows and Internships.

From a cost type point of view, the main categories were 'Personnel Expenses' with 68%, followed by 'Material Expenses' with 13% and 'Scientific & Regional Expenses' with 6% of total costs.

Overall, a positive 'Net Result' of CHF 612 K was achieved compared to a balanced budget. Compared to the 3 years Mid-term Plan, the result represents an increase of CHF 350 K.

4 Research Structure & Advisory Committees

4.1 AO Research Institute Davos (ARI) Organigram

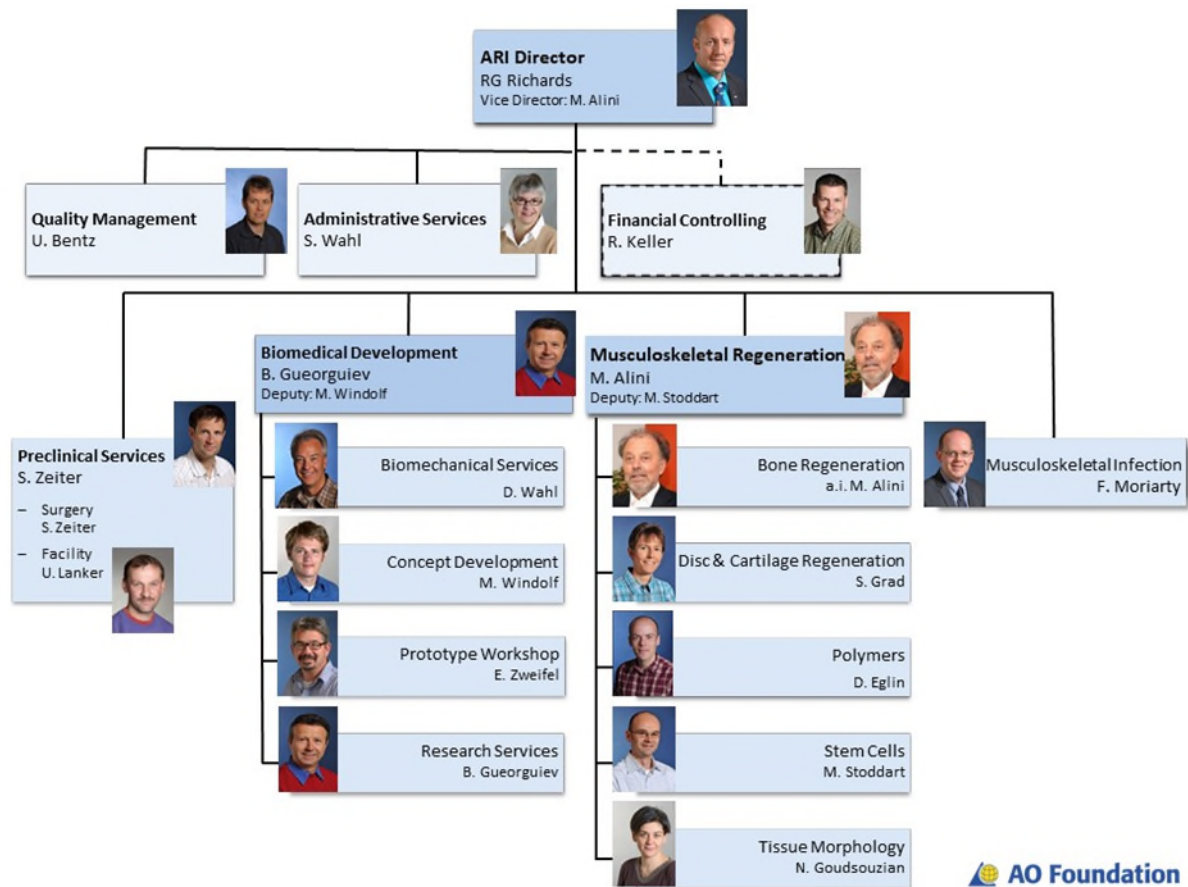

4.2 AO Foundation R&D Platform

The AO Research and Development (R&D) Platform monitors, reviews and further develops the strategy defining clinical needs and implementation on behalf of the AO Foundation (AOFB) in an advisory capacity. The AOFB is responsible for setting the overall R&D strategy for all divisions and Institutes, advising the AO Foundation on the overall funding and evaluating the overview outcomes for all AO research and development* initiatives. All research stakeholders are accountable to the AOFB. The AO R&D Platform coordinates among research stakeholders of the Institutes and clinical divisions to exchange information and develop best practice in overall operations and evaluation. It has no funding or decision authority. The R&D Platform is represented on the AOEM by the Director of the ARI. The R&D expert of the AOFB is the Chair of the R&D Platform. For the first half of 2019 the chair remained Prof Keita Ito, Orthopaedic Biomechanics Department of Biomedical Engineering, Eindhoven University of Technology, Netherlands who completed his term of office in June 2019. We thank him for his excellent advice and long-term friendship. For the second half of 2019 the chair was Prof Anita Ignatius, Director and Chair of the Trauma Research Center Ulm (ZTF), University Hospital Ulm, University of Ulm, Germany.

**This includes any R&D funded by the AO Foundation, it does not include industrial funded R&D or extramural funded R&D carried out through AO ITC or ARI.*

4.3 AO Research Institute Davos Advisory Committee

The ARI Advisory Committee (ARI AC) provides operational and strategic scientific advice to the ARI on behalf of the AO Foundation Board. ARI AC acts as both a sounding board and sparring partner for the Director and scientists of the ARI.

The ARI AC's tasks and responsibilities include advising ARI on:

- Portfolio of competences (skills of personnel and type of equipment)
- Strategy and priority setting for direct funds of ARI
- Exploratory collaborative research program(s)
- Business development and initial advice on technology transfer
- Regulatory issues
- Use of ARI funds
- Advancement of the ARI capabilities, to assure the efficient use of the infrastructure

The ARI AC comprises the following members:

- Prof Theodore Miclau (Chair, represents the ARI AC and member of the AO R&D Platform), Orthopedic Trauma Institute, USA
- Prof Chris Evans, Mayo Clinic, USA
- Prof Brian Johnstone, Oregon Health and Science University, USA
- Prof Joost de Bruijn, University of Twente, Netherlands



Left to right: Prof Geoff Richards, Prof Christopher Evans, Prof Dr Theodore Miclau, Prof Brian Johnstone, Prof Joost de Bruijn

5 ARI Teams / Personnel

5.1 Biomedical Development Program

Program Leader: Boyko Gueorguiev-Rüegg, Deputy: Markus Windolf

Team Members: Jan Barcik, Benjamin Burkhard, Jan Buschbaum, Jan Caspar, Daniel Ciric, Simon Comtesse, Carolin Danker, Ursula Eberli, Manuela Ernst, Dominic Gehweiler, Ladina Hofmann-Fliri, Lukas Kamer, Katharina Keck, Dominic Mischler, Karen Mys, Hansrudi Noser, Ronald Schwyn, Flurin Spiller, Peter Varga, Viktor Varjas, Dieter Wahl, Ivan Zderic, Erich Zweifel

Fellows: Satish Babu, Jan Dauwe, Kristin Handrich, Stoyan Ivanov, Moritz Lodde, Georg Osterhoff, Vasiliki Panagiotopoulou, Carlotta Pari, Jana Schader, Clemens Schopper, Alesandre Sitnik, Aleksandar Stefanov, Markos Valsamis

Guests: Yves Acklin, Charlotte Arand, Bijan Cheikh-Sarraf, Ladina Christoffel, Christian Giger, Tobias Helfen, Lisa Hofbauer, Dietrich Huibuur, Lena Kasper, Mark Lenz, Orlin Malouchev, Johanna Menze, Ruben Oliveros, Günther Peeters, Paul Raders, Melanie Rehli, Eladio Saura-Sanchez, Kerstin Schneider, Jason Shiroft, Philipp Stöckli, André Weber, Karin Wyss

Supporting the in-house processes for development and design of medical devices according to EN ISO 13485 and running advanced projects in close collaboration with clinical, scientific and industrial partners, as well as with the AO clinical divisions and the AOTC System, the Biomedical Development Program offers extensive know-how, expertise and experience in the fields of biomechanical testing and computational analyses to improve patient care.

A variety of clinical problems are addressed by development of new concepts, approaches, tools and novel implant systems for surgical applications and research in traumatology and orthopedics. The process of finding optimal solutions to clinical questions is enhanced by capabilities ranging from in silico methods to very well-equipped anatomical labs for quick and effective hands-on work when an anatomical environment is required. Specifically, tailored test procedures with implementation of supplemental X-rays, video and motion tracking systems are applied in diverse experiments on fracture fixation and joint reconstruction. Advancing with state-of-the-art technologies, powerful numerical methods and comprehensive tools for virtual simulations are integrated to answer various questions with special reference to biomechanical performance of bone-implant constructs. Modalities for medical imaging, processing and analysis, including CT scanners with a wide range of resolutions and scanned volumes, are



interlinked to account for increasingly sophisticated demands for morphological investigations, extract statistical and individual information from medical image data and extend the knowledge on variations of biomechanical bone characteristics and their role in persisting clinical problems. The capabilities of the Program are completed by the Prototype Workshop offering rapid and high-quality manufacturing of devices, tools and implants.

Test setup with a pelvic specimen being mounted for biomechanical testing by team members Dominic Mischler (left) and Carolin Danker (right).

5.2 Preclinical Services

Program Leader: Stephan Zeiter, Deputy: Urban Lanker

Team Members: Daniel Arens, Carmen Brazerol, Tim Buchholz, Caroline Constant, Peter Erb, Loris Faoro, Pierina Faoro, Andrea Furter, Nilo Hämmerl, Maria Hildebrand, Reto Müller, Dominic Perren, Monika Schneider, Valentina Stenger

Fellows: Brenna Pugliese, Charlotte Wittmann

Student Externs: Nora Krejczinger, Marija Matvejeva, Marine Michault, James Tapia-Dean

Guests: Josh Chang

Preclinical Services conducts *in vivo* studies for ARI internal project partners and collaborates with external partners such as companies and other research institutions. Due to the variety of project partners, a multitude of different topics related to the mission of the ARI to advance patient care through innovative orthopedic research and development were addressed via the studies performed in 2019. With a total of 11 projects, infection-related studies have the largest share in the total number of 22 conducted studies. Within these 11 different studies, a variety of different models and species were operated from subcutaneous implantation and plate-stabilized femoral osteotomies in mice to tibial screw insertion in rats, humeral defects in rabbits and tibial intramedullary nailing with revision in sheep.

The second most raised research topic addressed via *in vivo* studies was implant development with 3 successfully conducted studies looking at monitoring bone healing via smart implants and growth regulation in sheep. Another 3 studies investigated techniques of enhancing bone healing in rat, rabbit and sheep models.

Another important aspect of preclinical research is development of new models in order to address a growing variety of clinical problems. Two projects conducted in 2019 were aimed at developing such new models to establish a platform to test new treatment strategies for annulus fibrosus defects and infection of large bone defects. In the field of craniomaxillofacial surgery, one project looked at a new treatment technique for large mandibular defects using a sheep model.

For all *in vivo* studies performed at Preclinical Services, we aim for the highest standard of animal welfare, quality of generated data and occupational health and safety through consequent implementation of the 3R principles and adherence to the regulations of our GLP, AAALAC and ISO 9001:2015 accreditations. In this regard, in order to constantly challenging ourselves to improve, two studies were conducted looking at the refinement of analgesic protocols for different surgeries.

Being active in different societies i.e. the Preclinical Model Section at the Orthopaedic Research Society (ORS), the European College of Laboratory Animal Medicine (ECLAM), the Federation for Laboratory Animal Science Associations (FELASA) and the Swiss Laboratory Animal Science Association (SGV), ensures that we pursue best in class policies in the sensitive area of animal models. Preclinical Services was involved in or has organized national and international preclinical workshops, scientific sessions and practical courses throughout the year.

5.3 Musculoskeletal Regeneration Program

Program Leader: Mauro Alini, Deputy: Martin Stoddart

Team Members: Angela Armiento, Romain Bagnol, Cecilia Bärtschi, Valentina Basoli, Mauro Bluvol, Lino Casty, Elena Della Bella, Matteo D'Este, Nicolas Devantay, Nunzia Di Luise, Nicola Di Marzio, David Eglin, Priscilla Füllemann, Nora Goudsouzian, Sibylle Grad, Surya Häne, Johannes Hasler, Phelipe Hatt, Philippa Jörger, Tino Jucker, Hermann Kasper, Nadine Kluser, William Lackington, Yann Ladner, Wenyue Li, Zhen Li, Flavio Linardi, Junxuan Ma, Ursula Menzel, Graziana Monaco, Dirk Nehrbass, Daniele Pellicciotta, Marianna Peroglio, Robert Peter, Stijn Rotman, Andrea Schwab, Yemane Semere, Tiziano Serra, Astrid Soubrier, Christoph Sprecher, Despina Stefanoska, Keith Thompson, Letizia Vainieri, Daphne van der Heide, Andrea Vernengo, Sophie Verrier, Sebastian Wangler, Christina Wapp, Taiyo Yamamoto, Reihane Ziadlou

Fellows: Paras Ahmad, Shangbin Cui, Maria Antonia Gomez Sierra, Seyed Amir Kamali, Gowrishankar Muthukrishnan, Guillermo Sanchez Rosenberg, Céline Tourbier, Frederik Westbrock, Yichi Xu

Guests: Melanie Acosta, Ivan Al Saify, Dmitriy Alexeev, Talita Aygün, Enrico Biondani, Wei Guo, Nan Jiang, Joyce Kieran, Konstantin Kirchhoff, Diane Ledroit, Marta Marangoni, Dalila Petta, Judith-Johanna Pfannkuche, Lizette Utomo, Tim Wesdorp

The Musculoskeletal Regeneration program develops biological approaches addressing pathologies of the musculoskeletal system, with a focus on bone, cartilage and intervertebral disc. The ultimate goals are to identify strategies for prevention or attenuation of degenerative processes and to re-establish tissue functionality.

Bone Regeneration Focus Area

Bone healing in response to fracture involves a complex sequence of dynamic events, directed by numerous different cell types and growth factors. A critical factor for bone repair is the maintenance, or effective restoration, of an adequate blood supply, which is necessary to provide the damaged tissue with oxygen, nutrients and growth factors, as well as immune cells and mesenchymal stem cells required to repair the damage and induce new bone formation. Although bone generally has a high regenerative capacity, in some cases this inherent bone healing is compromised, which results in delaying healing or non-union of the bone fracture with increased health care costs and reduced quality of life issues for affected patients. While a variety of risk factors have been identified that predispose to an increased risk of developing delayed bone healing or non-union, it is currently not possible to identify specific at-risk patients at an early stage. Using *in vitro* and *in vivo* techniques, the aim of the Bone Regeneration Focus Area is to gain a greater understanding of the immunoregulation, cellular interactions and mediators, underlying impaired healing responses. By determining how cells such as immune cells, mesenchymal stem cells and endothelial cells normally interact during the repair process, and how this process is altered during impaired healing, we can then identify key events in the healing process. Our goal is to use tissue engineering and regenerative medicine approaches to promote bone healing, aimed at restoring bone integrity and its effective biomechanical properties.

Disc/Cartilage Focus Area

We aim at investigating mechanisms that lead to intervertebral disc (IVD) damage and evaluating novel biological treatment methods for IVD repair and regeneration. Acute and chronic damage to the IVD are major causes of low back pain. However, factors that contribute to loss of IVD function and the underlying pathophysiology are still poorly understood. We have established a whole IVD organ culture system with the ability to maintain entire discs with the endplates for several weeks under controlled nutrient and mechanical loading conditions. Within this bioreactor, the beneficial or detrimental effects of nutrition, mechanical forces,

and/or biochemical factors on disc cell viability and metabolic activity are investigated. We have developed various defect and degeneration models, allowing us to design and evaluate appropriate biological treatment strategies. These include implantation of cells, delivery of anabolic, anti-catabolic or anti-inflammatory molecules, biomaterials or a combination thereof. Data from *ex vivo* models are also correlated to *in vivo* observations to identify molecular markers of IVD damage or degeneration.

To study the potential of new therapies for articular cartilage repair and regeneration, a bioreactor system applying multi-axial load to tissue-engineered constructs or osteo-chondral explants has been established. The bioreactor mimics the load and motion characteristics of an articulating joint. Chondral and osteochondral defect and disease models enable us to test tailored treatments under physiologically relevant mechanically loaded *ex-vivo* conditions. Cell- and material-based therapies as well as chondrogenic or anti-inflammatory factors are under investigation for cartilage repair and regeneration.

Polymers and Surfaces Focus Area

Biomaterials for skeletal repair can provide structural and mechanical features for the filling of defects, but also be carrier for drugs, cells and biological factors. One of our goals is the development of 3D structures for bone and cartilage tissue engineering, using tailored polymers and composites manufactured with additive manufacturing processes. Our experience lies in the design of biocompatible, biodegradable polymers and their processing with controlled architecture and embedded biologics. A second field of research investigates the preparation of hyaluronan, a natural occurring biopolymer, based biomaterials which can be used to deliver drugs and cells. These injectable biodegradable materials have considerable potential in infection prophylaxis and tissues repair. We are also developing innovative technologies for the structuration and assembly of tissue-like matrices aiming to mimic for example, biological matrix mechanical and structural anisotropy.

Stem Cell Focus Area

The Stem Cell Focus area is particularly interested in stem cell therapies for bone and cartilage that could be applied within a clinical setting. We are increasingly investigating donor variation with the aim to predictively identify the potency of cells from individual donors. In the search for biomarkers to determine patient specific healing potential, extracellular vesicles and non-coding RNA sequences such as miRNA are increasingly being used as a diagnostic and therapeutic tool. The development of a serum-based biomarker approach would dramatically improve patient specific clinical decisions. We also aim to investigate the role of mechanical and soluble factors in the activation of mesenchymal stem cells, and the promotion of differentiation and tissue repair. Mechanical forces can be applied by way of rehabilitation protocols and are able to modify stem cell and macrophage function. Such studies are forming the basis of the emerging field of regenerative rehabilitation. In addition to the effect of load on direct differentiation, it is known that biomechanical stimulation can modulate the cell secretome. Investigating these changes could lead to the identification of new targets, that may be present during articulation. This offers new avenues for potential clinical therapies.

Tissue Morphology Focus Area

The Tissue Morphology Focus area primarily supports the other Focus areas within the ARI, but also works with external collaborators and commercial contractors. Hard tissue, undecalcified bone with or without implants, is the majority of the tissue that is processed. With specialized hard tissue microtomes, sectioning and modified stainings of these tissues are considered routine. Conventional microtomes such as paraffin and cryostat are also used, especially by the investigators performing *in vitro*, *ex vivo*, and cell culture experiments. Immunohistochemical staining is also routinely performed. Fluorescence microscopy, scanning electron microscopy (SEM), equipped with an Energy-dispersive X-ray spectroscope (EDX) to identify chemical elements for surface evaluation and profilometry, and confocal microscopy complement the spectrum of available techniques.

5.4 Musculoskeletal Infection Focus Area

Leader: Fintan Moriarty

Team Members: Willemijn Boot, Pamela Furlong, Marloes Hofstee, Iris Keller, Virginia Post, Claudia Siverino, Barbara Stanic, Eric Sumrall, Alexandra Wallimann

Fellows: Marc Antoine Burch, Andrew Foster, Aron Keshishian, Alexander Milstrey, Jolien Onsea, Igors Terjajevs, Ferdinand Weisemann

Guests: Clara M. Guarch Peréz, Mario Morgenstern, Martijn Riool

Fracture-related infection (FRI) remains one of the most challenging complications in orthopedic and musculoskeletal trauma surgery. FRI has been convincingly shown to delay healing, worsen functional outcome, and incur significant socio-economic costs. Antibiotic prophylaxis, wound debridement, and postsurgical care can reduce, but not prevent, the incidence of these infections and so novel interventional strategies are required. The musculoskeletal infection team work on in vitro, in vivo and ex vivo studies to better understand, diagnose, prevent and treat FRI.

A significant portion of the work performed by the Musculoskeletal Infection team involves collaboration with the preclinical services team in ARI to model FRI in a complex living system and provide robust evaluation of the new interventional technologies under development such as antibiotic loaded hydrogels. This expertise also extends to extramural studies performed with industrial partners to evaluate external innovations in the prevention and treatment of FRI prior to clinical implementation. In parallel to the preclinical in vivo evaluations, greater focus has been applied to the opportunities of working with human materials, either in vitro through basic cell culture studies and also in clinical studies with patients experiencing FRI. Through partnerships with clinician scientists in the AO network, we have gained access to biological materials from patients with FRI in an effort to more accurately study host pathogen interactions and microbiome studies, as two recent examples.

5.5 ARI Administrative Services

Manager: Sonia Wahl
Purchasing: Ulrich Bentz

Team Members: Isabella Badrutt, Claudia Barblan, Simona Ciriello, Carla Escher, Gregor Müller, Marisa Vivalda

The main goal of the ARI Administrative Services team is to provide an excellent service in all administration and organization fields of the ARI and to numerous AO Partners.



5.6 Operations standard and safety

Quality Manager: Ulrich Bentz

Successful 2019 routine audit of AO Research Institute Davos



From April 8 to 9 2019, an external auditor from the SQS (Swiss Association for Quality and Management Systems; www.sqs.ch) visited ARI two full days for the routine audit of the institute. ARI has passed the routine audit 2019 without any non-conformities requiring immediate actions.

The entire AO Research Institute Davos is certified according to the international standard ISO 9001:2015.

The Focus Areas Biomechanical Services and Concept Development of the Biomedical Development Program are additionally certified to develop and test medical devices according to EN ISO 13485:2016 standard.

ARI is one of the very few academic research organizations to have achieved this certification.

AAALAC international accreditation of Preclinical facility

The Preclinical Facility was first accredited by AAALAC International in early 2013. The Association for Assessment and Accreditation of Laboratory Animal Care International (AAALAC), is a private, non-profit organization that promotes the humane treatment of animals in science through voluntary accreditation and assessment programs. ARI is one of only 2 accredited institutions in Switzerland and the only accredited academic research institute in Switzerland. In November 2018, we received the third AAALAC international site visit, resulting in another 3-year accreditation.



GLP (Good Laboratory Practice)

ARI is listed as GLP compliant test facility since February 2016 (<https://www.anmeldestelle.admin.ch/chem/en/home/themen/gute-laborpraxis/pruefeinrichtungen.html>).

The second inspection took place in June 2018 and, on the 12 of October 2018, the Swiss Federal Office of Public Health renewed the statement of GLP compliance for the next 3 years. This is a major achievement for our institute after the AAALAC accreditation in 2013.

We are able to offer contract research services to all interested customers under GLP, especially if they want to get their medical devices approved by the FDA. Indeed, since the achievement of the GLP certification, all major commercial studies have been conducted under GLP (excluding pilot studies).

6 eCM Journal & eCM periodical

Editor-in-Chief: R Geoff Richards

Production Editors: Iolo ap Gwynn (external), Simona Ciriello

Webmaster, Web Editors: R Geoff Richards, Martin Stoddart, Simona Ciriello



eCM Journal (Eur Cell Mater) was the first Not-for-Profit, open access scientific peer-reviewed journal in the musculoskeletal field (initiated in 1999, implemented with the launch of the first volume in January 2001). It was created by scientists for scientists and is still run fully by scientists. eCM Journal is published by the ARI, a Not-for-Profit foundation in Switzerland.

eCM is an Open Access journal: all publications have been immediately freely available upon publication since the journal start. Articles are freely accessible to the public without any embargo period, irrespective of who funded the research. This is equivalent to the new term "Gold Open Access" where articles are immediately available for others to read, download and share. In 2000, reviewing the first papers before launch of published papers in 2001, eCM initiated a transparent review process, naming reviewers within all published manuscripts. Reviewers also have a transparent route for becoming an official listed eCM reviewer (member of the eCM International Review Panel).

In June 2019, Journal Citation Reports (JCR) announced eCM's 2018 Impact factor (IF) to be 3.682. JCR 5-year Impact Factor: 4.416.

Scopus CiteScore 2018 was calculated at 3.76. The Scopus CiteScore 2018 measures the average number of citations received in 2018 to documents published in 2015, 2016 and 2017.

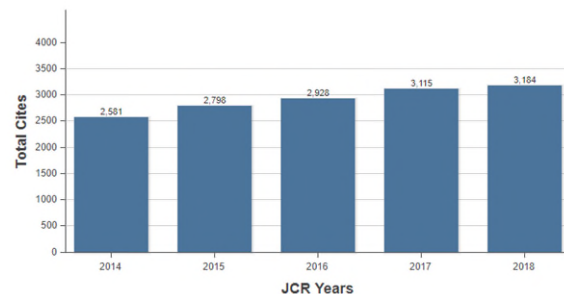
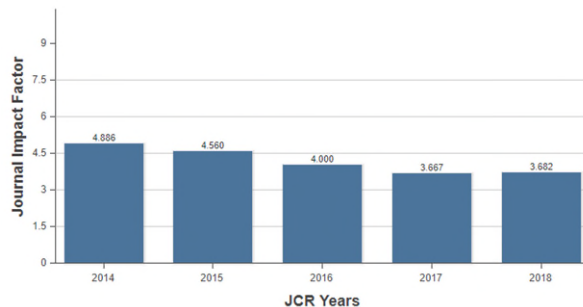

Since July 2018, eCM introduced the payment of an Article Publishing Charge (APC) of \$1000. The APC goes towards the costs of eCM staffing, web costs and general publishing costs.

From August 2018, after invitation, eCM is indexed on the China Knowledge Resource Integrated Database, where full eCM published articles are available directly after publication.

eCM publishes preclinical research that has clinical relevance in the musculoskeletal field (Orthopaedics, Trauma, Maxillofacial (including dental) and Spine). eCM's definition of the musculoskeletal field includes bone, teeth, cartilage, intervertebral discs, skeletal muscle (not smooth or cardiac muscle), tendons and ligaments (it does not include the spinal cord or neural tissues).

Within the musculoskeletal field areas include:

Assessment of materials for biomedical use

Tissue Engineering and Regenerative Medicine (TERM)

Structure, function, biology and biomechanics of connective and mineralized tissues

Stem and Progenitor Cells

Infection

eCM is listed in the following JCR categories:

JCR @ Category	Quartile in Category
CELL & TISSUE ENGINEERING	Q2
ENGINEERING, BIOMEDICAL	Q1
MATERIALS SCIENCE, BIOMATERIALS	Q2
ORTHOPEDICS	Q1

Ten good reasons for publishing a paper in eCM

1. World-wide Gold Open Access, authors retain copyright to their articles (CC-BY-SA).
2. eCM is a Not-for-Profit journal published by a Not-for-Profit foundation in Switzerland.
3. Rigorous open peer reviewing (reviewers have to request their name to be withheld).
4. Speed of publication.
5. Unique discussion with reviewers, as an integral section of the paper, allows sensible arguments to be included.
6. Scopus CiteScore 2018: 3.76. JCR Impact Factor 2018: 3.682. JCR 5-year IF: 4.416.
7. Indexed in the Science Citation Index Expanded and Web of Science (under the "Cell and Tissue Engineering", "Engineering Biomedical", "Materials Science" and " Orthopedics" categories), BIOSIS Previews, DOAJ, ROAD, Scopus, SJR, Journal Citation Reports/Science Edition, Google Scholar, National Center for Biotechnology Information (NCBI databases), NLM catalog (U.S. National Library of Medicine), PubsHub and SHERPA/RoMEO databases. eCM articles can be searched directly from PubMed and China Knowledge Resource Integrated Database.
8. Digital archive of manuscripts through CLOCKSS and Europe PMC. eCM is a member of CROSSREF (Crossref Digital Object Identifiers (DOI:10.22203/eCM), tagged to article metadata).
9. Transparent route to becoming a member of the International Review Panel.
10. Created (and run) by scientists for the benefit of Science rather than profit.

eCM Open Access Not-for-Profit online periodical

eCM Periodical was initiated in 2017, previously run within eCM journal as eCM supplements. eCM Conference Online Periodical is not part of the eCM journal publication but is owned as a separate part of eCM. It hosts all eCM official society meeting abstracts along with other abstracts for various congresses as collections of combined individual meeting abstracts in PDF format. The individual abstracts within the abstract collections have been peer reviewed by the respective conference organizers. eCM Periodical has been recorded permanently in the ISSN Register, ISSN: 2522-235X from the ISSN International Centre. The abstract collections do not have a DOI, and the abstracts are not searchable on PubMed. eCM Conference Online Periodical was established to solve the long-standing problem of eCM supplements being used in the JCR/Clarivate Analytics calculation of eCM impact factor and, unfortunately, accounting for approximately 15% of eCM citable items.



eCM journal council/eCM Editorial Board

6.1 eCM annual conference



The nineteenth eCM Conference, dedicated to "Orthopaedic Infection", was held at the Congress Center Davos, Switzerland, June 26-28, 2019. eCMXIX was organized by Dr Fintan Moriarty and Prof R Geoff Richards.

Orthopedic infections, including fracture-related infection (FRI), periprosthetic joint infection (PJI), osteomyelitis and associated surgical site infections (SSIs), remain amongst the most challenging complications in orthopedic and musculoskeletal surgery. 18 internationally renowned keynote speakers, including both clinicians and scientists, were invited to present the current state and recent advances in fundamental, translational and clinical research. From all submitted abstracts, 21 were selected as podium presentations and 40 were accepted as poster presentations. Over 120 participants joined the conference.

Awards were assigned as follow:

- WJ Metsemakers
Fracture-Related Infection
2019 Berton Rahn Research Award Winner
- EA Masters, AT Salminen, KL de Mesy Bentley, JL McGrath, SR Gill, HA Awad, EM Schwarz
Cloning the haptotaxis and durotaxis genes responsible for *S. aureus* invasion of the osteocytic lacuno-canalicular network during chronic osteomyelitis
Best oral presentation
- J Onsea, S Djebara, JP Pirnay, M Merabishvili, D De Vos, P Soentjens, J Wagemans, R Lavigne, WJ Metsemakers
Local bacteriophage therapy for chronic osteomyelitis: current hurdles and future perspectives
Best poster presentation

All abstracts from this conference can be found at

<https://www.ecmconferences.org/abstracts/2019/Collection5/ecm19.html>

7 Institutional and Professional Relations

Geoff Richards is Director of the AO Research Institute Davos since 2009 and has been a team member since 1991. He has an appointment as full Professor at the Medical Faculty of Albert-Ludwigs University, Freiburg, Germany (since 2015). He has an honorary Professorship at Cardiff School of Biosciences, Cardiff University, Wales, GB (since 2007). He is a Distinguished Professor at The First Affiliated Hospital, Sun Yat-sen University, Guangzhou, China (since 2016). He is a Fellow of Biomaterials Science and Engineering (FBSE) and Fellow of International Orthopaedic Research (FIOR), being elected in the inaugural ICORS College of Fellows class. In 2019 Geoff received the prestigious award of Honorary Fellow to his *alma mater*, Aberystwyth University in Wales. He has Doctor Honoris Causa from the Technical University of Varna, Bulgaria. In 2018, Geoff was appointed for a five-year term as member of High-end Foreign Experts Program, Sun Yat-sen University, State Administration of Foreign Experts Affairs, China. In 2017 Geoff founded of the International College of Fellows for Orthopaedic Research at the International Combined Orthopaedic Research Societies (ICORS), Steering Committee where he represents AO Foundation as a committee member. Geoff completed his chair of the International College of Fellows for Orthopaedic Research in 2019. Geoff is cofounder and Editor-in-Chief of the Not-for-Profit open access eCM Journal and eCM periodical. He is an Associate Editor of the Journal of Orthopaedic Translation. He has Life Honorary Membership of the Swiss Society of Biomaterials. He is president (2019-2021) of TERMIS Global (Tissue Engineering & Regenerative Medicine International Society). He is a guest lecturer of the MSc Course Skeletal Repair at the Department Health Science and Technology (D-HEST) of the ETH Zurich. Geoff is Vice President of Science City Davos. He is representative to the AOTrauma R&D Commission from ARI.



Mauro Alini is Vice Director of the AO Research Institute Davos since 2009. He is an adjunct Professor at the Division of Orthopaedic Surgery of the McGill University, Montreal, Canada. He serves as a member of the Award Committee for The GRAMMER European Spine Journal Award. He is a Fellow of International Orthopaedic Research (FIOR) and a Fellow of the Tissue Engineering Regenerative Medicine Society (FTERM). He is co-Editor in Chief of the Journal Orthopaedic Research Spine. He is on the Assistant Editorial Board of the European Spine Journal. He is a member of the Scientific Editorial Board of the eCM Journal. He is also in the international Editorial Board of the Journal of Orthopaedic Translation and Journal Orthopaedic Research. He is representative to the AOSpine R&D Commission from ARI.



Boyko Gueorguiev–Rüegg is program leader of Biomedical Development at the ARI. He is an Honorary Professor at the Technical University of Varna, Bulgaria in the fields of biomedical engineering and biotechnology. He is General Secretary of the European Orthopaedic Research Society (EORS). He is honorary Member of the Bulgarian Orthopedic and Traumatology Association and of the Serbian Trauma Association. He is a Member of the Academic Council at the University Multiprofile Hospital for Active Treatment and Emergency Medicine 'N I Pirogov', Bulgaria. He is appointed as Associate Editor and Editorial Board Member of the Journal of Orthopaedic Trauma, Section Editor for Orthopaedic Biomechanics at the Indian Journal of Orthopaedics, Academic Editor at the Editorial Board of Medicine, and Editorial Board Member of International Journal of Orthopaedics. He is representative to the AOTC System from ARI.



Stephan Zeiter is a program manager of the Preclinical Services at the ARI. He is the chair of the Preclinical Models Section of the Orthopaedic Research Society (ORS). He is a member of the scientific committee of the Swiss Laboratory Animal Science Association. For the European College of Laboratory Animal Medicine (ECLAM) he serves as a member of the council (treasurer) and he is the vice president of the Davoser Society for Natural Sciences (NGD). Stephan is a member of the eCM International Review Panel and a guest lecturer in the MSc Course Skeletal Repair at the Department Health Science and Technology (D-HEST) of the ETH Zurich. He is the representative to the AOVET R&D Commission from ARI.



Fintan Moriarty is a Principal Scientist and Focus Area Leader for Musculoskeletal Infection at the ARI. He is a guest lecturer at the Bern University of Applied Sciences, MSc program in Medical Technology. Fintan Moriarty is a lecturer in the MSc Course Skeletal Repair at the Department Health Science and Technology (D-HEST) of the ETH Zurich. He is a scientific editor for the eCM Journal and a co-organizer of the annual eCM conference on the topic infection. He is also a member of the Editorial Board of Journal of Orthopaedic Trauma (JOT).



David Eglin is a Principal Scientist and Focus Area Leader for Polymers and Surfaces at the ARI. He is elected council member of the Tissue Engineering and Regenerative Medicine International Society (TERMIS) EU Chapter. He is also a member of the International Editorial Board of Journal of Orthopaedic Translation (JOT). He is a member of the eCM Journal International Review Panel and a co-organizer of the annual eCM conference on the topic biofabrication. He lectures on the Skeletal Repair MSc module at the ETH Zurich and in the Biomedical Engineering MSc Program at the University of Bern. Since June 2019, he holds the chair of the translational Biomaterials Research in Orthopedics at the University of Twente, The Netherlands. Since June 2019, David Eglin holds a professorship at the University of Twente, The Netherlands.



Sibylle Grad is a Principal Scientist and Focus Area Leader for Disc and Cartilage at the ARI. She is adjunct professor in biomedical engineering at the Department Health Sciences and Technology (D-HEST) of the ETH Zurich and is organizer and lecturer of the ETH MSc Course Skeletal Repair. She is a member of the eCM Journal International Review Panel and a co-organizer of the annual eCM conference on the topic disc and cartilage. She is a member of the International Review Board of JOR Spine.



Furthermore, she is the topic chair for Intervertebral Disc sessions of the ORS Annual Meeting. Sibylle Grad is an ICRS Fellow member and she is Vice president of the Graduate School Graubünden AG.

Martin Stoddart is a Principal Scientist and Focus Area Leader for Stem Cells at the ARI. He is a full Professor at the Medical Faculty of Albert-Ludwigs University of Freiburg, Germany. He is honorary Professor at the Institute for Science and Technology in Medicine, University of Keele, UK. He is an elected Fellow of the Royal Society of Biology (FRSB). He lectures on the Skeletal Repair MSc module at the Department Health Science and Technology (D-HEST) of ETH Zürich. He is the Chair of the Orthopaedic Research Society (ORS) Basic Science Education Committee, and a member of the ORS Communications Council. He is Co-Deputy Chair of the International Cartilage Repair Society (ICRS) Basic Science Committee and an ICRS Fellow member. He is a member of the TERMIS EU Meeting and Sponsorship Committee. He is Scientific Editor for eCM Journal, Journal Editor for Tissue Engineering Parts A, B, C, an editor of BioMed Research International Orthopedics, an editor of Journal of Functional Morphology and Kinesiology and a member of the Review Editorial Board of Frontiers in Craniofacial Biology. He is the Co-ordinator and organizer of the yearly eCM conferences and a web editor of eCM Journal and eCM periodical. He is a member of the International Consortium for Regenerative Rehabilitation Leadership Council. He is the ARI representative to the AOCMF R&D commission.



Sophie Verrier is a Principal Scientist at the ARI. She is board member and upcoming president of the Swiss Bone and Mineral Society (SBMS). She is also active member of the Orthopaedic Research Society (ORS) where she chaired the Women's Leadership Forum Committee and is member of the ORS Annual Meeting Committee. She is a member of tissue engineering and regenerative medicine society (TERMIS) and of the eCM International Review Panel (eCM Journal). She is also co-organizer of topic specific annual eCM conferences.



Other Professional Relations

Daniel Arens is member of the credential committee of Specialised Veterinarians in Laboratory Animal Science (SVLAS).

Angela Armiento was elected member of the ORS International Committee for a 3-year term (2018-2021). She is the ARI representative in the Program Committee of the Graduate School Graubünden AG.

Valentina Basoli is lecturing at the University of Sassari Medical School, Italy on molecular biology, gene regulation and epigenetic within the course of biology.

Matteo D'Este was elected as a member of the Executive Committee of the Swiss Society for Biomaterials and Regenerative Medicine (SSB+RM). He lectures on the Skeletal Repair MSc module at the Department Health Science and Technology (D-HEST) of ETH Zurich.

Yann Ladner is a member of the Young Scientists organizing committee of the Swiss Society for Biomaterials and Regenerative Medicine (SSBM+RM). He is also assistant for the Practical Methods in Tissue Engineering MSc course at the ETH in Zurich.

Zhen Li is a Visiting Professor at the Medical School of Shenzhen University, Shenzhen, China. She is lecturing on the advanced research in intervertebral disc and cartilage at Shenzhen University and 7th affiliated hospital of Sun Yat-sen University, Shenzhen. She is the European Development Committee Member of International Chinese Musculoskeletal Research Society. Zhen Li is a member of the eCM Journal International Review Panel.

Junxuan Ma was visiting scientist at the Science Foundation Ireland funded Centre for Research in Medical Devices (CÚRAM) at the National University of Ireland, Galway for 3 months.

Hansrudi Noser is an Adjunct Professor at the University of Zurich at the request of the Faculty of Economics. In addition, he acts as a member of the High School Graduation Committee of Liechtenstein.

Marianna Peroglio is a certified Project Management Associate SGO. She was invited as visiting professor at INSA Lyon, France for 2 months. She is also a member of the eCM Journal International Review Panel.

Peter Varga is lecturing at the University of Berne on virtual tissue biomechanics laboratory within the program Master in Biomedical Engineering.

8 Good News

8.1 A new start up built on ARI Research

October 2019 has seen the launch of a new start-up company MimiX Biotherapeutics exploiting research and technology developed by ARI. MimiX founded by Marc Thurner and the ARI team is developing the next generation of Biofabrication solutions to provide Point-of-Care tissue engineering for regenerative, personalized and precision medicine. The technology has been developed by Tiziano Serra, a Research Scientist at the AO Research Institute in Davos, with the objective of creating well-defined biological patterns that self-assemble into functional



® tissues using sound waves. MimiX Biotherapeutics aims to deliver the next generation Biofabrication technology, that will enable tissue manufacturing for therapeutic and diagnostic purposes.

8.2 New extramural funding

Ongoing

German Research Foundation (DFG), Special Research Area (Sonderforschungsbereich, SFB): 'Collaborative Research Centre 1313 – Interface-Driven Multi-Field Processes in Porous Media'. The project partners include Prof Boyko Gueorguiev (ARI), in collaboration with Professor Oliver Röhrle (University of Stuttgart). Overall 4-year project funding is 8.5 million Euro, ARI funding for project area 'Fluid-solid phase change' is 100,000 EUR.

Mereo BioPharma, UK: 'Multicentre placebo-controlled double-blind study in adult patients with type I, II or IV osteogenesis imperfecta treated with BPS804'. The aim of the project is to investigate the effect of a new anabolic drug on individuals with osteogenesis imperfecta including pre-clinical studies and a multicentre human clinical trial. The project partners include Peter Varga (ARI), McGill University, Canada, and University of Berne, Switzerland. ARI funding is 63,800 CAD.

Swiss 3R competence Center (3RCC) on Refinement: "Rodents have a right for best surgical practice" This is a collaboration with Petra Seebeck (University of Zürich). For ARI Stephan Zeiter is the project partner. Total amount of funding is 395,000 CHF for 3 years. ARI will not receive financial report but personnel resources.

8.3 New AO Foundation intramural funding (grants beyond ARI retainer)

Ongoing

AO Development Incubator (AODI): 'Biphasic Plating – Next Generation Locked Plating'. Project partners are Markus Windolf (ARI) and Professor Devakar Epari (Queensland University of Technology). Overall project funding is 1.7 million CHF for 4 years.

AO Development Incubator (AODI): 'AO Fracture Monitor – Development Phase'. Main applicant and coordinator of the project is Markus Windolf (ARI). Overall funding is 4.0 million CHF for 4 years. The AO Fracture Monitor was created in ARI and is believed to be a major change to internal fracture fixation in the future.

AO Development Incubator (AODI) funded the ARI effort behind the newly launched MimiX Biotherapeutics start-up company developing the next generation of Biofabrication solutions to provide Point-of-Care tissue engineering for regenerative, personalized and precision medicine. Overall funding is 650,000 CHF for 2 years.

8.4 Awards

AO Foundation Berton Rahn Research Award

The Berton Rahn award, the AO's highest research award, is given annually in recognition of excellent clinically driven preclinical research that is funded by the AO directly or through one of the clinical divisions. In 2019, at the eCM conference in Davos on orthopedic infection, the award was given for outstanding and truly collaborative work in the field of fracture related infection to Willem-Jan Metsemakers. Prof Metsemakers is a Trauma Surgeon at the University Hospitals Leuven, Belgium, specialized in treating bone infections and who has previously been an ARI medical research fellow when he carried out his PhD in this field. In particular, the prize was awarded for the work he carried out within the AO at ARI, the AOTrauma clinical priority program (CPP) on Bone Infection, and the AO Technical Commission Anti-Infection Task Force (AITF). The award also recognizes his leadership of the Fracture-Related Infection Consensus Group - the first time we have seen cooperation on this scale between the AO Foundation and outside organizations such as the Orthopaedic Trauma Association (OTA), the European Bone and Joint Society (EBJIS), and the Pro-Implant Foundation.



left: Prof R. Geoff Richards, Director ARI, right: Prof Willem-Jan Metsemakers, University Hospitals Leuven, Belgium

ARI Director recognized for research achievements



*left: Dr Emyr Roberts, Chair of Council, Aberystwyth University
right: Prof R Geoff Richards, Honorary Fellow*

When ARI Director Prof Geoff Richards accepted an honorary fellowship from his alma mater, Aberystwyth University in Wales, on July 17, 2019, he represented the AO's contribution to the university's selection of those best of the best. Those present were recognized for an impressive array of achievements, from a key figure in the global campaign to eradicate polio to a former first minister of Wales. Richards was among nine honorary fellowship recipients who were recognized for their connections to the University of Wales and for outstanding contributions to their chosen fields.

Richards, who earned a Bachelor of Science degree in cell and immunobiology from Aberystwyth University in 1990, followed by a Master of Science degree in electron microscopy in 1991 and a PhD (while based in Davos) in cell adhesion to implant surfaces 1997, was honored for his research on metal implant interfaces in orthopedic trauma. That research, carried out at ARI, has led to major improvements in the design and manufacture of fracture fixation products and significant advancements in patient care worldwide. Richards holds professorships at respected international universities in Britain, Germany and China.

“His specialist degree and masters set him onto a unique career path,” said Prof Christopher J Thomas, Aberystwyth University Pro Vice Chancellor for Research, Knowledge Exchange & Innovation. “From this west-Wales University, Geoff journeyed to Switzerland and joined the AO Research Institute in Davos in 1991. One of the world's leading Research Institutes in orthopedics, the ARI houses over 100 multidisciplinary scientists who undertake cutting-edge research in regenerative medicine, tissue engineering, biomaterials and implant science.”



*(l-r) Prof Chris Thomas, Pro Vice-Chancellor – Research, Knowledge Exchange and Innovation.
Prof R Geoff Richards; and Prof Elizabeth Treasure, Vice-Chancellor, Aberystwyth University*

In 1999, Richards cofounded the eCM Journal, a pioneer in open access publishing and today one of the top-rated trauma research journals. In 2009, he was appointed as director of ARI, an institute now with 90 highly interconnected projects underway. He has supervised nine PhDs, fifteen master's theses, four medical/veterinary theses and two diploma theses. Additionally, during Richards' tenure as ARI director, the institute has hosted 14 researchers from Aberystwyth University.

Richards said his own career demonstrates what passionate young researchers can accomplish in the right setting and with hard work. His advice to those considering a career in research at this time is simple: "If you want to go into research, after your master's or PhD (which is really the beginning), spend a year or two in industry to get industry's perspective; and if you are going into orthopedics, try and get some time with a surgeon to watch their problems so that you are not operating in a bubble." he said. "Stay in touch with the real world. Be passionate and love what you are doing."

One requirement of Aberystwyth University Honorary Fellows - and one that Richards had fulfilled well before he was selected as an honorary fellow - is that they establish and maintain a connection to the university. He is taking that commitment one step further: On the same day that he received the honor, ARI and the university signed a memorandum of understanding providing for ARI to host two Aberystwyth University veterinary medicine students for three-month internships each year. Aberystwyth University will pioneer the first veterinary medical school in Wales in 2021, working closely with the Royal Veterinary College, University of London, the oldest veterinary school in the English-speaking world.

Honorary Membership Award from Bulgarian Orthopedic and Traumatology Association



At the 14th Congress of the Bulgarian Orthopedic and Traumatology Association (BOTA) held in Varna, Bulgaria from October 3-6, 2019, Prof Boyko Gueorguiev was elected as an Honorary Member of the Association for his significant contribution to active participation in preclinical research of the young generation orthopedic trauma surgeons. The Diploma of Honorary Award was given to him at a special ceremony by the BOTA President Prof Asen Baltov and Vice President Prof Kalin Mihov.

Bulgarian Orthopedic and Traumatology Association President Prof Asen Baltov (left) and Vice President Prof Kalin Mihov (right) hand over the Honorary Membership Award to Prof Boyko Gueorguiev (middle).

AO Technical Commission Certificate of Merit

On December 7, 2019 at a meeting of the AO Technical Commission Chairs, Markus Windolf was honored with the prestigious AO Technical Commission Certificate of Merit, recognizing the integral role he has played in driving AO innovations forward.

AO Technical Commission Trauma Chairman Prof Michael Raschke, (left) and AOTC Director Claas Albers (right) hand over Certificate of Merit to Markus Windolf (middle).



Giving Markus the award, Prof Michael Raschke, Chair of the AO Technical Commission Trauma, noted the numerous significant contributions he has made over the years, specifically his work on a simplified navigation system based on shape recognition to improve orthopedic procedures, and on a concept that automatically determines the required screw length during bone drilling. Both these concepts sparked great interest among the AO Technical Commission's Expert Groups and are currently in translation to clinical application.

Markus said "It is an honor to receive this award in recognition of all the efforts which have been required to advance these concepts to stages which allow final product realization. The highest reward for every inventor will, however, be to see ideas become reality. There is still some way to go. Medical device development is a bumpy road. There are so many influential factors which must be considered in order to turn a concept into a solution. Without the support of the whole ARI's Concept Development Focus Area team it would not have been possible to be so successful. We have achieved this intermediate milestone together. The Certificate of Merit is some extra motivation for all of us and shows that we are heading in the right direction." Led by Markus, Concept Development plays an essential role in AO working on innovations and on improvements to currently available solutions in orthopedic care with the significant contributions of all team members: Jan Buschbaum, Peter Varga, Viktor Varjas, Ronald Schwyn, Dominic Gehweiler and ARI's prototype workshop.

With so many potential avenues to explore, Markus emphasizes, team priorities must be clearly set. "You have to focus on the most important topics. It doesn't make sense to try to solve everything at once. Bundling resources and staying focused will be our key to success."

Two other very promising innovations that are currently being developed by Markus and his team are the Biphasic Plate, an implant concept to install a beneficial mechanical environment for bone healing at the fracture site, and the AO Fracture Monitor.

Biphasic Plate development team receives best paper award at the 4th AO Trauma Asia Pacific Scientific Congress

At the 4th AO Trauma Asia Pacific Scientific Congress in Taipei, Taiwan, May 24-25, 2019, Prof Devakar Epari (QUT), Markus Windolf (ARI), Ronald Schwyn (ARI), Stephan Zeiter (ARI), Roshan Gurung (QUT) and Ladina Hofmann-Fliri (ARI) were recognized for the development of the biphasic plating concept by receiving the best paper award.

Prof Devakar Epari (right) receives the best paper award during the ceremony at the 4th AO Trauma Asia Pacific Scientific Congress as representative of the biphasic development team.



8.5 ARI new MOU's (Memorandums of Understanding)

A Memorandum of Understanding for academic cooperation was signed between Shenzhen University, China, and the ARI. Prof Guangqian Zhou, Director of the Center for Anti-aging and Regenerative Medicine, is the main collaborator within this MoU. The Parties agree to implement within the rules and regulations applicable in each of the institutions and subject to the availability of funds and resources, programs and activities that may include:

Submission of collaborative research proposals; student and/or academic and administrative staff exchanges; joint research activities; exchange of publications, reports, and other academic materials and information where such exchange shall be of benefit to both Parties; and cooperation on other activities and programs in areas of mutual interest, where such sharing shall be of benefit to both Parties.

8.6 New Board Positions

Tissue Engineering and Regenerative Medicine International Society (TERMIS)

ARI is proud to announce that Professor R Geoff Richards took office as President of the TERMIS Global on January 1, 2019 for a three-year term.

Commenting on his election, Richards said that he is honored and humbled to have been selected by the global membership from the three chapters of Aisia, America's and Europe and thanked them for placing their trust in him. He added that his goals for his term as president would include supporting the society globally, improving governance and related processes, introducing a method for national tissue engineering societies to affiliate to TERMIS chapters to strengthen the global society, and to give Fellows of TERMIS active roles to mentor the next generations.



Richards also wishes to empower the Student and Young Investigator Section (SIYS). Finally, he also wishes to review the vision and mission of the society. The overarching principle for his term as president is, he stressed, a focus on harmonization of chapter processes, governance, and collaboration. Richards is looking forward to attending all chapter meetings each year and highlighted that he is open to both suggestions and constructive criticism. In 2019 Geoff updated a new shorter defined Mission for the society. He created the first Code of Ethics for the Society and Diversity statement along with replacing the legal counsel, secretary and treasurer increasing gender balance at the same time.

ARI Principal Scientist Sibylle Grad is inspiring a new generation of researchers as adjunct professor at ETH Zurich



ARI Principal Scientist Sibylle Grad, PhD, has been appointed adjunct professor (Privatdozent) in biomedical engineering at the Health Sciences and Technology Department at her alma mater, the Swiss Federal Institute of Technology in Zurich (ETH Zurich). Grad, who works in ARI's Musculoskeletal Regeneration Program, joined ARI in 2000 upon completion of her first postdoctoral training and has been a spring semester lecturer for the Skeletal Repair course at ETH Zurich since 2015.

"What I really enjoy is motivating these students – primarily master's degree students – and engaging them about the importance of our work," says Grad, whose appointment was effective February 1, 2019. "What are the clinical problems we need to solve? What are options and opportunities? What will the future treatments be? I hope to open students' minds and encourage critical thinking, and the students seem to respond to that." As part of the course, each semester's Skeletal Repair students are engaged in both classroom lectures and a two-day practical course at ARI, where they benefit from osteosynthesis training and gain insights into ARI's lab work.

Grad, who earned her pharmacy degree and her PhD in natural sciences from the Department of Cell Biology at ETH Zurich, is excited to play a role in inspiring a new generation of scientists. “Teaching is an opportunity to engage the next generation of researchers in emerging areas of medical technology,” Grad explains. “If you had told me many years ago, when I was a student at ETH Zurich, that I would one day be teaching in the same classroom where I once sat as a student, I would never have believed it. ETH Zurich has a special place in my heart.”

Principal Scientist Eglin’s University of Twente professorship adds to ARI’s global credibility

With his appointment as a professor at the University of Twente in Enschede, the Netherlands, ARI Principal Investigator David Eglin, is the eighth currently employed ARI scientist to become a professor, further underscoring ARI’s reputation as a world-class research institute.

As a member of the faculty of technology at University of Twente, Eglin will teach and mentor master’s-level biomedical engineering students in the translation of biomaterials research in orthopedics. A polymer chemist with extensive expertise in the synthesis and processing of



responsive materials, Eglin joined ARI in 2006. Today, he is leader of the polymers team and has published more than 90 peer-reviewed articles, holding eight patents. He was the 2011 recipient of the European Society for Biomaterials’ Jean Leray Award recognizing outstanding young scientists’ research contributions to the field of biomaterials (won by Richards in 2004). Eglin said he believes that research and teaching are complementary pursuits. “My work at ARI will benefit my teaching because it allows me to bring our scientific advances as well as the interdisciplinary aspects of the work to the next generation of biomedical engineers” said Eglin, who was a guest lecturer at the University of Twente for five years prior to being appointed professor. “At the same time, it is always interesting to be in touch with the next generation of researchers and ARI will gain access to a pool of young, motivated biomedical engineers. Additionally, the research collaboration between ARI and the University of Twente will be strengthened.” ARI Director Geoff Richards added that Eglin’s appointment further demonstrates ARI’s credibility as the academic backbone of the AO Foundation. These are not just given titles. Earning a professorship entails as many as seven levels of evaluation” Richards explained. “The number of professors in ARI demonstrates our credibility as a world-class research institute.”



Matteo D'Este was elected as a member of the Executive Committee of the Swiss Society for Biomaterials and Regenerative Medicine (SSB+RM).

8.7 Collaborations

AO and ETH Zurich extend partnership to create value through opportunities for next generation of musculoskeletal scientists

The AO Foundation and the Swiss Federal Institute of Technology in Zurich (ETH Zurich) have signed a contract to extend their partnership to provide world-class research opportunities for master's students and young scientists of the Institute's Department of Health Sciences and Technologies (D-HEST). The four-year extension ensures continued value creation among the next generation of musculoskeletal scientists by offering ETH Zurich students access to as many as four AO Foundation Fellowships and up to five AO Research Opportunity Awards each year.



ETH Zurich students (left to right), Benjamin Burkhard, Yann Ladner, and Simon Comtesse have received AO Foundation Fellowships to conduct research at ARI.

ARI Director Prof R Geoff Richards said the partnership illustrates the AO's commitment to improving patient care. The relationship, which Richards initiated with then ETH Zurich President Ralph Eichler, has had a positive impact. "We have had some excellent, talented ETH Zurich students spending time here working in our clinically-guided research projects," he said. "Some of these are now performing joint PhDs based here at ARI through ETH. ARI is proud to be partnering with mainland Europe's highest rated university, along with other leading universities in the United Kingdom and Europe, the United States, and Asia."

ARI Principal Scientist Sibylle Grad, explained that "eleven D-HEST students have received AO Foundation fellowships to conduct research at ARI since 2015 when the original partnership agreement between the AO and ETH Zurich was signed." Their projects cover a vast array of relevant topics, from 'Directing osteogenic differentiation of mesenchymal stromal cells in vitro' to 'Cross-talk between mesenchymal stem cells and intervertebral disc cells.' In fact, ARI research experience has laid the foundation for one student to earn the ETH Medal while others earned top grades for their theses and secured PhD positions at top universities and research institutes - including ARI. "The agreement provides for CHF 88'000 in AO support over the next four years, or CHF 22'000 per year to fund four AO Foundation Fellowships valued at CHF 3'000 each and five AO Opportunity Awards valued at CHF 2'000 each," said Grad. "For students with little or no income, this financial support makes a valuable contribution towards the cost of living while recipients are doing their research in an ARI lab or at another institute/university in collaboration with their ETH Zurich department."



AO Foundation Fellowships allows master's students to conduct musculoskeletal research in ARI's labs in Davos, and the AO Opportunity Awards support D-HEST and ETH Zurich biomedical engineering students' master's and doctoral students' exchange visits to the ARI lab and partners' labs worldwide to increase researchers' networks and collaboration.

Annual block course brings ETH Zurich and ZHAW students to Davos for hands-on training experience.

“This partnership really is a win-win collaboration for both the AO and ETH Zurich because it enhances research in the field of orthopedics and musculoskeletal regeneration,” Grad explained. “Recipients get access to a worldwide network of scientists and surgeons who are leaders in their fields, as well as access to world-class lab facilities. Master’s students coming to ARI get very good supervision and exposure to our team of experienced and expert research scientists. At the same time, the agreement gives ARI staff access to certain ETH Zurich resources such as cutting-edge technologies that represent the future of patient care, and fosters collaboration with top ETH Zurich professors and their teams.”

AO Research Institute Davos takes key role in new iPSpine project



Group picture of participants in the Horizon 2020 iPSpine project kick-off

The ARI has joined 19 partners in a five-year project titled iPSpine (induced pluripotent stem cell-based therapy for spinal regeneration).

The kick-off meeting took place in Utrecht, The Netherlands on February 12-13, 2019. ARI scientists Sibylle Grad, Marianna Peroglio, and Mauro Alini are all involved in the project, which comes under the European Union's Horizon 2020 program to fund research into advanced therapies.

The study looks specifically at chronic lower back pain, which is a leading cause of disability and morbidity across the globe, affecting over 700 million people each year. This project aims to develop treatments that will help restore spinal function.

ARI has a significant role within the iPSpine project, as the newly developed cell- and material-based treatments will be tested using ARI's well-established whole intervertebral disc organ culture system. The project consortium includes 20 partners based in Europe, the United States of America, and China.

Strengthening the collaboration between the AO Research Institute Davos and Inselspital Bern

On November 22nd, 2019, the ARI invited the team of the Orthopaedic Surgery and Traumatology Department of the Inselspital University Hospital of Bern for a joint symposium at the AO Center. After a warm welcome by the ARI Director Prof Geoff Richards, four sessions of scientific presentations with discussions were held, covering the topics of bone, cartilage, intervertebral disc regeneration and biomechanics. In each session, the colleagues from Bern (PD Dr Fabian Krause, Dr Michael Künzler, Dr Christoph Albers, Prof Benjamin Gantenbein) and ARI scientists (Prof Martin Stoddart, Dr Peter Varga, Prof David Eglin, PD Dr Sibylle Grad) presented current research activities and future directions, fostering intense interactions between the two institutes. Within a tour through the AO center, the visitors obtained further insight into the ARI laboratories and recent projects, and the dinner offered an additional great opportunity to plan future collaborations.



Participants of the joint symposium with surgeons and scientists from Inselspital and University of Bern.

AO Research Institute Davos builds tight collaboration with China Scholarship Council and Education Department of Chinese Embassy at Bern

The ARI has received steady funding from Sino Swiss Science and Technology Cooperation (SSSTC) in the recent years organized by the China Scholarship Council (CSC) and SNSF. The CSC and SSSTC has sponsored the living cost of several research fellows from China for their stay at ARI as academic guests, including Shan Tian, Zhiyu Zhou 2016-2018, Yichi Xu 2018-2019, Wei Guo 2018-2019, and Nan Jiang 2019-2020.



Visit of the Educational Counsellor Ms. Ru Xi (3rd from the left) from Chinese Embassy at Bern at ARI on 12.04.2019.



Visit of the China's Minister of Education Mr. Baosheng Chen (the 5th from the right on the 1st row) at ARI on 16.11.2019.

Seminar between ARI and Institute of Biomechanics, Hamburg University of Technology (TUHH)

On January 11-12, 2019 a traditional jointly organized seminar between the ARI and the Institute of Biomechanics at the Hamburg University of Technology (TUHH) detailed current activities of both institutes focusing on topics in biomechanics. Special guest at the seminar was AO Foundation founder, Prof Stephan Perren.



Organizers and guests of the seminar between ARI and Institute of Biomechanics at TUHH (from left to right): Prof Boyko Gueorguiev, Gerd Huber, Prof Michael Morlock, Prof Nick Bishop, Markus Windolf, Prof Stephan Perren, Prof Geoff Richards.

Seminar between ARI and Institute of Biomechanics Murnau



Participants from ARI and Institute for Biomechanics Murnau at the joint seminar on hot topics in biomechanics.

On March 14, 2019 a joint seminar between the ARI and the Institute for Biomechanics Murnau (IFB) took place following a closer insight in the ARI activities during a tour through the Institute. After introductory presentations by Prof Peter Augat (IFB) and Prof Boyko Gueorguiev (ARI), the institutes presented current and past activities and discussed possibilities for future collaborations on hot topics in biomechanics in two scientific sessions.

Collaborative Research Fellowship at the Queensland University of Technology

Jan Barcik, a PhD candidate at ARI's Biomedical Development Program, conducted a three-month collaborative research fellowship at the Queensland University of Technology (QUT) in Brisbane, Australia, where he pursued research within a joint project between ARI and QUT focusing on mechanobiology of bone fracture healing. The fellowship was organized in collaboration with Devakar Epari, Professor of Biomedical Engineering at QUT. During his stay in Brisbane, Jan had the opportunity to immerse himself in the clinical reality by observing multiple live orthopedic trauma surgeries conducted by Prof Michael Schuetz and his team, thereby gaining valuable experience.



Prof Devakar Epari (left) and Jan Barcik (right) in the middle of the QUT campus.

8.8 Congress news

The scientists of tomorrow – Annual block course brings ETH Zurich and ZHAW students to Davos for hands-on training experience



Students from ETH Zurich and ZHAW Winterthur at the skeletal repair course.

Fifty-six students from the Swiss Federal Institute of Technology in Zurich (ETH Zurich) and the Zurich University of Applied Sciences campus in Winterthur (ZHAW) explored a variety of skeletal repair topics during a hands-on skeletal repair course on April 26-27, 2019 at the AO Center. The group – 33 master's students from the ETH Zurich Department of Health Sciences and Technology and 23 bachelor's biomedical engineering students from ZHAW – got the unique opportunity to learn from world-class skeletal repair experts and work in the state-of-the-art ARI labs.



Students and instructors working in hands-on workshops and practical exercises.

Organized by Prof Sibylle Grad, ARI Principal Scientist, the two-day annual event provides participants with a rich and unique learning experience. Students worked together in teams to explore a variety of skeletal repair topics, including bioreactor-guided whole organ cultures of intervertebral discs, adenovirus transfection, 3-D printing, implant infection, in vivo model for skeletal research, cartilage bioreactor, joint anatomy, and endoprosthesis materials. Moreover, the course included two case-based clinical workshops to provide participants with basic knowledge of clinical and radiological techniques, reading and understanding X-ray images and evaluating mechanisms of injuries.

"What was really unique about this course were its hands-on aspect and the opportunities for students to interact closely with the surgeons," said Grad who is also Adjunct Professor in biomedical engineering at the Health Sciences and Technologies Department at ETH Zurich. "At ARI, we are helping to train the scientists of tomorrow – and that is important because there are still a lot of unsolved clinical questions in the area of skeletal repair".



Contributing key expertise for the event with Dr Veit Schoenborn and Dr Raphael Jenni from Kantonsspital Graubünden in Chur, and Prof Daniel Baumgartner and Prof Bernd Heinlein from ZHAW School of Engineering, as well as ARI scientists from the Musculoskeletal Regeneration Program, Biomedical Development Program, Musculoskeletal Infection Group, and the Preclinical Services team.

8.9 Visits of ARI

Stephan Perren AO Trauma Research Traveling Fellowship First fellowship recipients complete visit to the ARI



Left to right: Alberto Jorge-Mora, Spain; Prof Stephan Perren, AO Foundation founder; Eran Keltz, Israel; Prof Boyko Gueorguiev, ARI Biomedical Development program leader; Prof R Geoff Richards, ARI Director, in the AO Center.

The Stephan Perren AO Trauma Research Traveling Fellowship was established to give young and enthusiastic surgeons with specific interest in orthopedic trauma care the opportunity to visit ARI and Julius Wolff Institute, Berlin, Germany.

One of the first recipients was Alberto Jorge-Mora, Consultant, University Hospital of Santiago de Compostela, Spain. He was motivated to apply for the fellowship and come to ARI to get a first-hand insight into its latest innovations. Jorge-Mora planned to take what he had learned in Davos back to his home country, where he also hopes to develop productive and mutually beneficial relations between ARI and the University Hospital of Santiago de Compostela.

"The best part of the experience was meeting other people who are interested in the same things as you, there are a lot of researchers, and that is not common in clinical practice, so it is really nice to meet them here". He described his meeting with Prof Perren as "one of the best moments, he is an incredible, kind guy with a very interesting history. One of the best researchers I have ever met". Describing his experience at ARI he said, "I have really learned a lot – new friends, collaboration, new ideas".

Eran Keltz, Resident, Rambam Health Care Campus, Israel, was also appointed a Stephan Perren AO Trauma Research Traveling Fellow. On having the opportunity to visit ARI he shared, "I have always been fascinated by trauma and wanted to see where things are developed from and what I can contribute back home. It really opens your mind".

ARI Fellowship advances NUI Galway student's research – and the AO's mission



ARI Fellow Kieran Joyce is proof of how the AO Foundation and its network promote excellence in patient care and outcomes in trauma and musculoskeletal disorders.

Joyce, a doctorate and medical doctor student at the National University of Ireland Galway (NUI Galway), completed a four-week fellowship at ARI as part of his research into the glycomic profile of intervertebral disc (IVD) in health and degeneration for biomaterial functionalization.

Given ARI's long collaboration with NUI Galway's Prof Abhay Pandit, an established authority on biomaterials and one of Joyce's mentors, the foundation for a successful fellowship was well established. "When we met at the European Orthopaedic Research Society (EORS) Global Summit in September 2018, we had the idea: Why don't we apply the same methods described in his paper to our preclinical IVD organ testing system at ARI to validate our organ cultures in comparison?" said ARI Principal Scientist PD.Dr Sibylle Grad, who supervised Joyce's ARI Fellowship with ARI's Dr Zhen Li.

Joyce believes his ARI Fellowship will advance his research well into the future. "In terms of expertise, ARI is one of the best institutes I've worked in, and ARI's experts were always ready to answer questions," he explained. "This fellowship offered me a basis to continue to develop and make a difference not in just one patient's life, but in the lives of many patients," he said. A 2018 EORS Travel Award helped offset travel expenses related to the fellowship.

8.10 AO Research Institute Davos (ARI) at 60

The ARI celebrated the 60th anniversary of its founding on June 22, 2019. This was an apt moment to look back at how ARI has changed and grown over this time, and to review some of its highlights and achievements.



Left: Prof Stephan Perren, AO Foundation founder (1984), ARI Director 1967-1995
Right: Prof Martin Allgöwer, AO founder (1958), the first ARI Director 1959-1962

This showcases some of those features that make ARI what it is today, a central part of the AO Foundation and the orthopedic research community around the world. Established by the founding members of the AO on June 22, 1959 as the Laboratory for Experimental Surgery Davos, now ARI undertakes advanced research to support the AO Foundation's mission.

ARI's high quality applied preclinical research and development, both exploratory and translational, focuses on clinical applications and solutions to problems that currently arise in treatment. Today, ARI is a leader in its field, as it works to improve the efficacy of treatments available to patients. It has a close relationship with the AO's medical community and has built productive relationships with universities and academic societies around the world.

Its research programs are carried out in key areas (biomedical development, musculoskeletal regeneration and infection, and preclinical services) and involve several areas of promising new developments – including sensors (such as the AO Fracture Monitor), sound acoustic-wave 3D cell printing, microRNA therapy and diagnostics (theranostics), and biomarkers for personalized medicine.

Since its founding, the city of Davos has been central to ARI's identity. To this day, ARI's advanced laboratories and research facilities are based in Davos, and the institute forms an essential part of Davos' status as a hub for scientific research. Founded on June 22, 1959, the "Labor für experimentelle Chirurgie Davos" (LECD - Laboratory for Experimental Surgery Davos) was established. The AO's founders set it up as a non-profit institution. Under Martin Allgöwer's initial direction, it carried out research into polytrauma, shock, the pathophysiology of burns, and the histology of wound repair.

AO History, a picture from the Laboratory for Experimental Surgery in the Villa Fontana, Davos.



It was ARI Director Stephan Perren who gave ARI its focus on bone biomechanics, in particular the interaction of mechanical and biological influences on bone formation, remodeling, and healing. From 1967 to 1995 ARI made notable progress in its research into the biology of internal fracture fixation - developing new implants (e.g., dynamic compression plates with limited bone contact, and locking plates) and tissue-friendly surgical procedures. It was during this time that ARI moved from its initial home, the LECD, to a custom-built facility known as the AO Center - the AO's headquarters.

The AO is rightly proud of the recent advances ARI's Musculoskeletal Regeneration Program has made in cartilage and intervertebral disc research. This multidisciplinary group takes a holistic approach to tissue engineering in the repair of traumatic musculoskeletal injuries. The program brings together specialist knowledge in cell biology, polymer chemistry, and bioengineering to investigate cell/material interactions in vitro and in vivo. This research is classed into five focus areas: bone regeneration, intervertebral disc and cartilage regeneration, polymers and surfaces, stem cells, and tissue morphology. The multidisciplinary nature of the group is what makes it so unique, and all these areas interact to develop new trauma repair treatments.

The preclinical research facility (PCF) is an essential feature in ARI's longstanding, recognized, position as a research leader in this field. The first facility to house animals was built in 1975, with modern facilities developed in 2003, 2010, and work is currently ongoing on a new facility able to house specific pathogen free (SPF) sheep. When completed this would be the first facility of its kind in Europe.



Preclinical Services, ARI

The ability to carry out the full spectrum of research – from online computer models, to in vitro laboratory work, to bioreactor work and in vivo research – remains a key feature of ARI's unique contribution to high-quality research activity in these areas. Animal welfare has always been, and remains, central to the AO and to ARI in its research. ARI is proud to have received AALAC accreditation for the preclinical facility in 2013, and all its research is carried out to the highest standards, as attested by its ISO certification. ARI received ISO 9001:2015 recertification in April 2018, and its concept development and biomechanical services received ISO recertification for ISO13485:2016 in April 2018. ARI's preclinical facility and the musculoskeletal infection and tissue morphology groups received Good Laboratory Practice (GLP) certification in 2016, which is a very important accreditation to have when translating ideas to the clinic.

Manuela Ernst demonstrates the AO Fracture Monitor at DKOU.



ARI's leading Biomedical Development Program develops innovative solutions to current issues in musculoskeletal treatment. It carries our development, research, and service work in the following areas: Biomechanical Services, Concept Development, Research Services, and Prototype Workshop. They all work closely with other parts of the AO such as the clinical divisions and AOTC System, and with clinical, scientific, and industrial partners. The focus is ensuring the highest standards throughout the full cycle, from initial concept development, to prototype development, all through to clinical application.



Preclinical Services, ARI

As a leading scientific research institute focused on clinical problems, ARI is always looking to change and adapt to the ever shifting and increasingly complex health care environment. At the same time, however, its core values remain AO values – excellence in research combined with dedication to nurturing young talent and supporting able researchers at all stages of their careers. ARI is proud to run fellowships that welcome outstanding researchers (both medical and PhD's) from all over the globe, and equally proud to partner with academic and research institutions worldwide. For ARI, these past six decades have seen some tremendous advances in research and treatment in its field. The next six look to be just as exciting.

Living the AO spirit, ARI's directors deliver 60-year research pioneer legacy



ARI group, 2018

The ARI, which celebrated its 60th anniversary on June 22, has pioneered a significant number of scientific breakthroughs over this time. These advances ranged from providing—during the AO's first decade – scientific support that enabled compression fixation and developing the dynamic compression plate (DCP), an implant function that is still the backbone of tissue-friendly internal fracture fixation, to the groundbreaking digitalization-enabled treatments under development today.

Five directors have led the institute's march to the future of patient care, each bringing a passion for the research so essential to the evolution of evidence-based medicine.

“Research is central to the AO. AO founding father Maurice E Müller knew that research had to be a really strong arm to push the founders' ideas through to acceptance,” said ARI Director Prof Geoff Richards, who has led the institute since 2009. “Maurice chose Martin Allgöwer as the first director in 1959 because of his interest in research.”



left: Maurice Müller (L) and Martin Allgöwer (R) pictured at Müller's 80th birthday celebration in Bern, 1998.



right: Herbert Fleisch (the Institutes second director) and his wife skiing during the 10th AO Davos Courses in 1969.

Allgöwer and his small team focused on polytrauma, particularly the pathology of burns and the histology of wound care. In addition to his considerable scientific research skills, Allgöwer also made solid and convincing arguments and, as cofounder Müller once said, had “a charisma that made him a good mentor.”

In 1963, Prof Herbert Fleisch became ARI's second director, and his research earned him – and ARI – international recognition, particularly for his research on bisphosphonates, a class of drugs used to treat osteoporosis and similar diseases.

In 1969, Fleisch – at only 36 – was awarded a full professorship leading the University of Bern's Institute of Pathophysiology. He was succeeded as ARI director by Prof Stephan Perren, who was one of the four AO Foundation founding fathers; the AO Foundation was founded in 1984 from the AO association at the time: Association for Internal Fixation (AO/ASIF).

Perren moved ARI's research emphasis toward mechanobiology of tissue repair, with a focus on the interaction of mechanical and biological influences on bone formation, remodeling, and healing. Under his leadership, important strides were made in internal fracture fixation, including the development of plates with limited and no contact with the underlying bone avoiding contact necrosis and tissue-friendly surgical procedures. Perren, who retired in 1997, was globally renowned for his strain theory explaining tissue deformation as a critical mechanical factor that controls fracture healing. At 87, he was still a senior scientific advisor to ARI and remained active in research at ARI until his death at the end of 2019. Lauded as an icon and a visionary, he was equally revered for his commitment to mentoring young researchers.



left: Stephan Perren (L) and Vreni Geret (R) at a ceremony marking 20 years of her work with AO right: Stephan Perren Honorary Professor Ceremony in Quebec, Canada



“He is absolutely special,” said Vreni Geret, who joined ARI as a lab technician in chemistry in 1963. “He instilled confidence in us...and was a mentor to me and many other people.”

Perren was succeeded in 1997 by Prof Eric Schneider, who drove a multidisciplinary approach to addressing a wide variety of fundamental and clinical research questions. Under his leadership, ARI explored new focus areas ranging from fracture fixation of the osteoporotic skeleton to using a combined approach employing conventional load-bearing fixation devices supplemented by biodegradable scaffolds to enhance bone defect regeneration. The multidisciplinary approach was evidenced by the vast array of specialties represented by ARI staff.

In 2009, Richards took ARI's leadership reins, having completed nearly 20 years of implant surface research which importantly, have changed and improved patient care. He since has pushed the institute toward new frontiers at the dawn of the digitalization-driven Fourth Industrial Revolution. ARI today is at the forefront of using technology to advance patient care: developing sensors to measure fracture healing, digital systems to aid anatomical positioning of implants, repositioning of fractures and digital aids for accurate drilling and screw insertion, unique bioreactors for mechanical loading of cartilage and disc to mimic degeneration and study regeneration, pioneering the use of microRNA to predict the pace of fracture healing and likely also useful for therapy (theranostics), and use of fully resorbable (degradable), antibiotic-loaded thermo-responsive gel to reduce the infection risk at implant sites. The institute's motivated teams from preclinical surgery, biomedical services to musculoskeletal regeneration and the infection group are highly interconnected with universities and academic institutions worldwide and attract medical and scientific fellows globally to study at ARI.



*left: Prof R Geoff Richards, current ARI Director, at the eCells & Materials congress (eCM), June, 2015
right: Prof Erich Schneider, former ARI Director*

"We have 90 strongly interconnected projects ongoing at ARI," Richards said, adding that eight members of ARI's current full-time staff are professors, demonstrating the institute's academic credibility: "When I came to ARI in 1991, there were two professors in the institute – Prof Stephan Perren and the late Prof Berton Rahn (vice director and my supervisor at that time). With all these accomplishments, the renowned AO spirit – a shared enthusiasm for solving clinical patient and surgical problems – is a red thread running through ARI's innovative orthopedic research and development in support of the AO's mission

"This spirit is certainly very alive in the research institute today," Perren said in 2019.

9 AO Research Institute Davos Medical Research Fellows

The ARI's Research Fellowship program again attracted resident and senior surgeons from around the world. Some of the many benefits to a surgeon are:

- Creation of tangible results in research
- Possibility of medical publication as a co-author (depending upon time and input)
- Knowledge on how to approach research challenges in future
- Inspiration from being part of a world renowned international multidisciplinary R&D team
- Inside knowledge attainment of the AO Foundation
- Enlarging personal networks for future R&D and AO Foundation activities
- Chance to have a research friend/mentor that is always easy to contact



*ARI Fellows,
2019*

Research Fellows



Paras Ahmad: University Sains Malaysia, Malaysia (Country Pakistan)
ARI Project: **Extraction of all types of bone morphogenetic proteins (BMPs) from human femoral head in order to assess levels of different BMPs and their gene expression analysis**

During my time at ARI as a medical research fellow in the Musculoskeletal Regeneration Program, I will be focusing on BMP's, human bone marrow mesenchymal stem cells, osteogenic differentiation using different laboratory procedures including RT-PCR, cell culture and expansion, western blot, histological staining, protein and RNA extraction as well as isolation and quantification. Full of experiences and impressions, not only because of the research work at AO, but also living in Davos. I have expanded my international vision, touched the academic front, worked within a multidisciplinary team of renowned scientists and provided myself with a new lifestyle. The group activity made me enjoy my life in Davos and strengthened the sense of belonging and motivation to work even harder. This is, for sure, the most unforgettable experience in my life!



Marc-Antoine Burch: University Hospital Basel, Switzerland
ARI Project: **Impact of Analgesic Drugs on Orthopedic Device Related Infection**

For the daily practice of a surgeon, the initials AO represent knowledge, learning, accuracy and improvement of care. I had the opportunity to undertake a fellowship of one year at ARI, during which I realized that it was much more than that: it is a global network of physicians, scientists, inventors, computer freaks, veterinarians and animal care givers, engineers, administrators, and economists which act with a fantastic enthusiasm in order to achieve more for patient care. I joined the Musculoskeletal Infection group, under the lead of Dr F Moriarty and could work on various projects related to orthopedic device related infections. The broad-mindedness and expertise in play make me certain that efficient solution to this major clinical challenge will shortly emerge from Davos.



Caroline Constant: University of Montreal, Canada

ARI Project: **Biomechanical effects of different cortex screw head sizes in equine medial condylar fracture fixation (HeadsUP)**

During my time as a veterinary fellow in Preclinical Services, I had the opportunity to actively participate in several projects with various focuses from biomechanics, tissue regeneration to infection studies. Furthermore, I participated in the development and evaluation of a new cortical bone screw for equine patient in order to help improving surgical outcomes of large animal species. I advanced my surgical and researcher's skills from the insight into all stages of preclinical studies and strengthened my critical thinking. I was very lucky to become a part of the ARI and AO multidisciplinary team, to share my passion for orthopedics with other passionate fellows and students, as well as with the healthcare professionals collaborating with the ARI.



Shangbin Cui: The first affiliated hospital of Sun Yat-Sen University, China

ARI Project: **Neopeptide Peptides as Biomarkers of Early IVD Degeneration – Investigation in Organ Culture**

I have been working as a medical research fellow in the Disc and Cartilage Regeneration group for one year. During this time, I focused on the neopeptide of intervertebral disc (IVD) degeneration, IVD organ culture, degeneration model, elisa, RT-PCR, histology and biomechanics. I really enjoyed working in ARI, not only because of the good laboratory equipment, but also because of the kind people and good working atmosphere. Everyone is always willing to help. People in ARI treated each other as a family. ARI although taught me what is team work and collaboration. The great ideas of research are not always coming from books and literatures but coming from the talks and communication with our colleagues. The excellent environment in Davos and the ARI group activities are the things I will never forget.



Jan Dauwe: University Hospital Leuven, Belgium

ARI Project: **Osteosynthesis of Proximal Humeral Fractures and Investigation of the Added Value of 3D Segmented CT Images to Their Classification Accuracy**

I started at ARI in August 2019 as a medical research fellow and have worked in the Biomedical Development Program focusing on proximal humeral fracture plate osteosynthesis under the supervision of Peter Varga and Boyko Gueorguiev. During my stay at the Institute, I have learned more than conducting profound research and working together in an innovative team. I have also had the opportunity to meet renowned scientists and surgeons from all over the world thanks to the extensive AO network. I have made a lot of international friends and colleagues. Living in Davos is an experience as such, the astonishing nature and environment help to understand the fresh AO spirit. I am extremely grateful for this incredible one-year lasting journey.



Maria Gomez: University de los Andes-Fundacion Santa Fe de Bogota, Colombia

ARI Projects: **1. HealBone - Non-Viral Gene Delivery Therapy To Immunomodulate and Enhance Fracture Healing in Long Bones**
2. NeuroBac - Investigating the Efficacy of Neuromodulation for Improving Anti-bacterial Responses in Orthopaedic Device-related Infection

During my time at ARI as a research fellow in the Musculoskeletal Regeneration Program, I focused on determining an optimal non-viral gene delivery vector for the transfection of rat BM-MSCs. To assess the efficacy of this vector I focused on the areas of cell culture in a monolayer and a 3D

environment using collagen scaffolds and hydrogels, confocal microscopy, histology and micro-CT. For the NeuroBac project I focused on obtaining data to assess the feasibility to target neuropeptides such as CGRP to enhance the host antibacterial response. To do so I used skills in the areas of cell culture of neuronal cells (N7-23) and using bacterial cultures collected condition medium to then assess the capacity of this bacteria to produce neuropeptides. To assess this I used fluorescent bioparticles such as *S.Aureus* bioparticles, and CellRox, each reacting to a different stimuli which generated more or less fluorescences which was then read by a multiplate reader (VIKTOR) which assessed fluorescences.

This year was full of experiences being able to live in a town as wonderful as Davos and learn from a multidisciplinary team on research at ARI, which has created another new perspective on the view of orthopedics. Being in an international environment such as the AO has allowed me to broaden my academic horizons, expand my international vision and meet friends that became family. This experience has allowed me not only to grow professionally but also personally, without doubt it was the most unforgettable experience in my life!



Kristin Handrich: Universitätsmedizin Mainz, Germany

ARI Project: **Symmetry analysis of the pelvic ring (SymPel)**

During my time at ARI as a research fellow in the Biomedical Development Program I worked with 3D pelvic CT models and analyzed (a)symmetric features of the pelvic ring. I was able to get insight into the work as a researcher and I also gained a lot of new knowledge, which I benefit from in my everyday life as a medical doctor in the clinic. It really was a pleasure and an honor to work together with this gorgeous team. I did not only enjoy my work but what really made Davos so special to me were the kind, friendly and brilliant people I have met. I will never forget

the great time I had at ARI and in Davos and I am very thankful to have been able to work at the renowned ARI!



Amir Kamali: Shiraz University, Iran

ARI Project: **Secretome characterization of human mesenchymal stem cells stimulated with intervertebral disc conditioned medium**

During my fellowship I have gained extensive experience with human primary cell isolation and culture in research with a solid experience in different molecular and cellular biology techniques. These techniques include proteomics and related bioinformatic analysis, cytotoxicity assay, DNA and RNA purification, Quantitative-Real-time PCR, multiplex ELISA, spectrophotometry, immunostaining and the subsequent data analysis.

Thanks to working in a multidisciplinary and multicultural institute, I developed my communication skills so that I can engage with scientists within and outside of the biological field. I have had many beautiful days during my stay and enjoyed the unique natural beauty of Davos.



Aron Keshishian: University of Saarland, Germany

ARI Project: **Impact of analgesic drugs on orthopedic device related infection and osseointegration of orthopedic devices**

During my time in Davos, I worked in the Musculoskeletal Infection group on a project that investigated the effects of commonly used analgesic drugs on the infection risk and the influence on osseointegration of the implants in a rat model. It was very revealing to work on a relevant medical topic but not as a medical doctor in direct patient contact but in the lab. I got to know a lot of interesting people from all around the world and made some new friends. I am thankful that I had the chance to spend 9 months

in Davos at the ARI and think that my future life as a surgeon will be positively affected by what I have learned in that time.



Moritz Lodde: University Hospital Münster, Clinic for Trauma-, Hand- and Reconstruction Surgery, Münster, Germany

ARI Projects: **1. Biomechanical testing of common fixation methods of fragility fractures of the pelvis. 2. Instable anterior butterfly pelvic ring fractures – a biomechanical comparison of two different fixation methods. 3. Biomechanical testing of common fixation methods of C 1.3 posterior pelvic ring fractures.**

During my stay at ARI as a medical research fellow in the Biomedical Development Program I focused on different synthetic pelvic models, simulation of different fracture patterns of the pelvic ring, development of biomechanical test setups, motion tracking with high-precision measurements, and different fixation techniques of pelvic ring fractures. The time at ARI was full of new, exciting experiences and positive impressions. Working within a multidisciplinary and international team of renowned scientists highly ameliorated my scientific knowledge and skillset. ARI provided a fantastic infrastructure for research at the highest level. The group activity within Biomedical Development, the activities in Davos and the surrounding valleys and the travels were wonderful and strengthened my motivation to work even harder on my projects. The stay in Davos is the experience of a lifetime and I highly recommend working within the ARI.



Jolien Onsea: University Hospitals Leuven, Leuven, Belgium

ARI Projects: **1. Evaluation of the 2-AI implant coating in an in vivo rabbit fracture model (C3-coating) 2. Bacteriophage therapy for fracture-related infection due to staphylococcus aureus (PHAGE-S)**

During my time at ARI as a research fellow in the Musculoskeletal Infection group, I focused on the prevention and treatment of fracture-related infection. Although it was only a 4-month fellowship, I really enjoyed my time in Davos and learned a lot. I particularly enjoyed working in an interdisciplinary team of international scientists.



Brenna Pugliese: Cummings School of Veterinary Medicine at Tufts University, North Grafton, Massachusetts, USA

I joined the Preclinical Services team in July 2019 following a year in equine clinical practice. As a veterinarian with a strong interest in translational orthopedic research, this fellowship represented a unique opportunity to gain hands-on experience with R&D. Not only have I refined my surgical skills but through working on a wide range of projects I now have a solid foundation in the care and use of animal models, study design, and collaboration with a large interdisciplinary team. I was also very fortunate to participate in my first AO Trauma Principles course in Davos; the skills which I developed in this course, designed for human surgeons, will serve my patients well as I will head into a large animal surgery residency. The opportunity to live and hike in these beautiful mountains, to experience an entirely new culture, and to work with those making a global impact in orthopedics is truly once-in-a-lifetime.

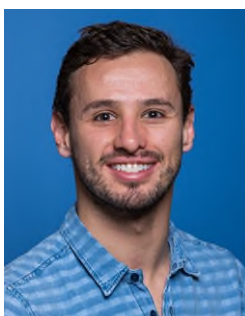

Guillermo Sanchez Rosenberg: School of Medicine, Universidad Francisco Marroquin, Guatemala

ARI Project: **Development of a physiologically relevant ex vivo fracture callus model**

As a medical research fellow, I have gained vast amounts of practical skills and theoretical knowledge: from the cell culture lab to the prototype workshop, the ARI scientists and personnel have patiently taught me, to name a few; how to develop a proper study design, use and maintenance of stem cells, perform biomolecular and histological analyses, and the basics of 3D design, printing, and machine manufacturing. Much more important is the fact that I have been able to develop personal relationships and share quality

time with the brightest minds that are pushing the boundaries of knowledge in the fields of trauma and orthopedics. An additional bonus is the beautiful natural surroundings of Davos. Professionally, I am sure this experience will provide the scientific foundations upon which a solid academic career will be built. Personally, my mental horizons have been blown away into limitless possibilities. In the following months, I will continue working in the field of machine learning and medical imaging and will strive to give back, exponentially, what the AO has given to me.



Jana Schader: Kantonsspital Graubünden, Chur, Switzerland
ARI Project: **Patient Specific Proximal Humerus (PSPH)**

During my time at ARI as a medical research fellow in the Biomedical Development Program, I focused on finite element analyses, 3D printing, medical engineering and biomechanics. Being able to dive into the world of engineering as a surgeon broadened my horizon to an extent I could never have imagined. I am convinced that merging these two worlds will be the future of medicine. I am grateful that I was able to be part of this extraordinary team of experts of different fields working together hand in hand. Davos has become my second home over the past years because

of those exceptionally welcoming people who share their knowledge and expertise on a familial basis.



Clemens Schopper: Department of Orthopedic Trauma, University Hospital Ulm, Germany (Country Austria)

ARI Project: **Biomechanical testing of new implant solutions for fixation of femoral neck and diaphyseal fractures**

I had the pleasure to be part of the Biomedical Development Program for one year. As part of the unique team I was able to contribute to many different projects. I had the chance to make new friends, colleagues and partners – I travelled all throughout Europe. Focus of my research were biomechanical considerations in the lower human extremity. It was my pleasure to collaborate with Boyko Gueorguiev, Dieter Wahl, Peter Varga,

Markus Windolf, Ivan Zderic, and Dominic Mischler on recent issues related to relevant questions in the field of musculoskeletal research. Promoted by my work, I was able to get in touch with experts from all over the globe which opened the door to scientific translation to me. Besides the huge scientific and academic benefit, I was able to gain out of this time, I had the pleasure to share moments of friendship and understanding with persons who became my friends. Being a once-in-a-lifetime-chance, I would choose to make use of this fellowship every time again if I had the opportunity.



Igors Terjajevs: Hospital of Traumatology and Orthopedics, Riga, Latvia

ARI Project: **Development of 3-dimensional in vitro models of bone infection (Immunobact 4)**

The aim of the project was to study antibiotic tolerance of 3D model of S.aureus abscess communities. During the time of my fellowship, I was a member of the Musculoskeletal Infection group and had a great opportunity to perform in vitro and in vivo studies on implant-related bone infection. Being part of the AO was always one of the major inspirations since I have started my surgical practice. In the ARI, I have met and worked with extraordinary people, who are great researchers and true

fans of the idea of making our patients healthier. The most spectacular experience in my life and there are no ifs, ands, or buts about it!



Ferdinand Weisemann: BG Unfallklinik, Murnau, Germany

ARI Project: **Differentiating septic vs. aseptic nonunion in human long bone with biomarkers in human blood plasma**

During my fellowship in the Musculoskeletal Infection Program I was introduced into the analyzing methods of proteomics. I used this insight to test human and sheep blood samples on different biomarkers and tried to link them to bone infection status. Apart from that I got a huge input from other ARI programs on the latest thoughts in biomaterials and biomechanics and had lots of opportunities to meet scientists and surgeons from all over the world to widen my horizon. I also got to know

a part of the local culture, their enormous ambition to conquer the beautiful mountains and especially enjoyed the variety of melted cheese. Thanks to ARI for this great experience, I would love to come back one day!



Charlotte Wittmann: Veterinary University of Hannover, Hannover, Germany

ARI Projects: **1. Investigating the impact of analgesic and anti-inflammatory drugs on the risk and treatment of fracture related infection. 2. Development and optimization of a subcutaneous infection model in mice.**

During my one-year fellowship at the Preclinical Facility of the ARI I was involved in various projects investigating skeletal healing and trauma care. In my role as a fellow I was assisting in surgeries of sheep, rabbits and rodents, and I was responsible for the induction and maintenance of

anesthesia as well as necessary post-surgery evaluation tools. I was fortunate to have had the opportunity to become more involved by being a project leader. As a project leader on a study investigating the effect of various analgesics on fracture related infection, I was responsible for project coordination, post op plans, and animal care. Importantly, I was trained to independently perform study relevant surgery in rats, which was an amazing and incredibly valuable experience. Furthermore, I was able to work closely together with the Musculoskeletal Infection group in order to compose my doctoral thesis. In this study we are aiming for the development and optimization of an infected subcutaneous implant model in mice which has not been described at the ARI yet. Besides being a part of the AO family and working together with world renowned scientists I enjoyed every bit about living in Davos. Having grown up surrounded by mountains, I considered myself lucky having been able to live in close touch with nature again. I made friends from all over the world and appreciated our little "Landwasser" community very much. All the incredible hiking trips, skiing weekends and excursions will remain memories I will never forget!

Guest Students



Melanie Acosta: Hochschule Furtwangen, Villingen-Schwenningen, Germany (country Cuba)

ARI Project: **VariDon – Chondrogenic prediction and reversion of non-responsive hSDSCs**

I joined with pleasure the Musculoskeletal Regeneration group for six months for my bachelor thesis, where I focused on synovial stem cells as an alternative cell source for cartilage tissue engineering. Being part of the ARI showed me how important it is in research to work together as a team in order to achieve not only the goal of a project but to generate more knowledge and methods. I could experience an atmosphere where I had

the freedom to ask every small question and be surrounded by researchers, that were pushing me to achieve more, without forgetting how important the balance is between life and work.



Talita Aygün: Hochschule Furtwangen, Villingen-Schwenningen, Germany

ARI Project: **SDSC-LOAD + BMP2 – Synovial derived stem cells as alternative cell source for cartilage issue engineering – The impact of mechanical stimulation**

For my bachelor's thesis I joined the Musculoskeletal Regeneration group at ARI for six months. Not only does the ARI offer great opportunities, but also supports their students in gaining a lot of knowledge in their early research experiences. Because of this there is an environment created which makes sure that you can ask anyone for advice without any hesitations. Besides that, the work at ARI taught me that it is extremely important to work as a team in order to learn from each other and to receive new ideas. Adding to a great working atmosphere, the team always had in mind to plan activities outside of the work area to enjoy beautiful Davos.

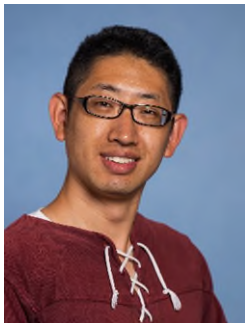

Nan Jiang: West China Hospital of Stomatology, Sichuan University, Chengdu, China

ARI Project: **Development of decellularized ECM bioink from intervertebral disc for 3D printing**

As an ARI fellow, I joined the disc and cartilage regeneration group. My major subject was Development of decellularized ECM bioink from intervertebral disc for 3D printing. I was so happy to work in such an academic team focusing on IVD regeneration. During the one year of staying here, I improved my research skills in the fields of decellularization and bionic development. Furthermore, I really enjoyed the skiing and beautiful surrounding in Davos.



Judith Pfannkuche: Albert-Ludwigs-University, Freiburg, Germany

ARI Project: **RenoDisc – The potential of Losartan as an anti-inflammatory mediator in degenerative disc disease**

Initially I planned to work, study and stay for 6 months at ARI in the Disc and Cartilage Regeneration team for my doctoral thesis. The supportive work environment, enthusiastic teachers and always new possibilities that surrounded me in these first months made me extend my stay for 6 more months. Over the course of the year, my scientific as well as medical horizon has widened considerably and in areas that I haven't even anticipated at the beginning. The family spirit so often mentioned in connection to ARI gives young scientists and doctors the chance to develop in the direction they are most interested in and new ideas are encouraged and supported. I feel greatly honored to have been able to stay for four seasons in the beautiful mountain city Davos to work on my medical career together with great minds and make new friends from all over the world.



Céline Tourbier: University Medical Center, Freiburg, Germany

ARI Project: **BMPER – Investigating effects of BMPER on osteogenic and chondrogenic differentiation**

I joined the stem cell group at ARI working on a collaborative project for one year. ARI offered me an encouraging and supportive working environment in which I developed the scientific and personal skillset needed for research. I had the chance to learn from very experienced scientists, who were always open to give advice and exchange thoughts and ideas. From day one the support given by the ARI family was exceptional and benefited me and my project greatly. Also, Davos itself is a special place. To clear your mind, you just need to look at the pristine mountain ranges or enjoy some outdoor activities like skiing or climbing.



Tim Wesdorp: Erasmus University Medical Center, Rotterdam, The Netherlands

ARI Project: **RAIMBO and AOCD Consortium**

I am a medical doctor in orthopedic surgery and currently doing my PhD research at the Erasmus University Medical Center. As part of my PhD, I joined the biomedical materials group. Here we combine the experience I have on different immune cells with the know-how of ARI on 3D printed biomaterials for tissue repair. I had the unique opportunity to learn a lot on biomaterials, its design and the whole production process. Furthermore, for me as an absolute mountain lover there was no better place to be.

Here it was possible to combine work with the beauty of ski touring, cycling and a new sport I learned, cross country skiing. I will for sure be back to enjoy more of the mountain life with the friends I made.

Internships



Simon Comtesse: Swiss Federal Institute of Technology, Zurich, Switzerland

ARI Project: **Prediction of interfragmentary movement, loading, and implant strain based on finite element modelling and strain measurements with the AO Fracture Monitor**

After a successful bachelor's degree at the Department of Health Sciences and Technology, I was very happy to have received an AO Foundation Fellowship for my master's thesis at ARI, as Davos combines my passion for biomedical research and freestyle skiing. The whole time in Davos was a great experience. It gave me the opportunity to gain

experience in both experimental biomechanics and computational studies, as well as meeting interesting people. The collaboration with surgeons, engineers and experienced scientists was extremely interesting. Additionally, through working in the Biomedical Development Program with novel technologies like finite element modelling and smart osteosynthesis plates that measure bone healing, I was able to acquire a lot of different skills and knowledge, which will provide a wide basis for any future work of mine.



Carolin Danker: University Stuttgart, Germany

ARI Project: **Virtual Fracture Segmentation and Reduction**

I came to Davos in November 2019 to join the Biomedical Development team for a seven-month internship. After completing my Bachelor studies in Biomedical Engineering, I wanted to gain practical experience and develop my knowledge and research skills further. During my time in ARI I got insights into exciting projects and was also able to develop my own project. Furthermore, I particularly enjoyed working in a very international and interdisciplinary environment, which gave me the opportunity to get to know many people from a wide variety of backgrounds.

Besides that, I really enjoyed living in Davos, being surrounded by beautiful nature and experiencing the Swiss culture. Overall, the time at ARI has been very valuable for my professional and personal development and I am looking forward to the rest of my stay.



Nicola di Marzio: University of Turin, Italy

ARI Project: **3D-Sound induced morphogenesis (SIM), application in tissue engineer and regenerative medicine**

I started in ARI as an intern and had the possibility to learn more about biomaterials and biofabrication, indeed I was working with a novel technology which is based on sound induced waves applied to soft hydrogels. It creates patterns of biological materials dispersed into the fluid. I learned about the various applications which this technology is useful for. I applied it to create complex patterns of calcium phosphate particles inside different hydrogels useful for guided bone regeneration,

but I also used the 3D-SIM to create innovative *in vitro* vascularized models. The time in ARI led me to join a new born start-up venture and I began my PhD research work. I personally realized how well connected and stimulating the AO environment is, hence, it was easy for me to get exposed to other research and medical prospective not covered by my research work. The life in Davos has something unique as the reality to be surrounded by beautiful mountains, I was able to step out my houses' door with my ski gears and be ready to have fun. I learned soon how to ski and enjoyed the nature around Davos in summer and winter time.



Priscilla Fülleemann: Reutlingen University, Germany

ARI Project: **Identification of mechanical conditions promoting hypertrophic endochondral differentiation in vitro (MechEndro)**

After recently having finished my Bachelor's degree, I started an internship in the bone group at ARI. In the project I focused on the cultivation of MSCs under different conditions to study how the cells differentiate under strain in the bioreactor. In the laboratory I had the opportunity to learn and apply many exciting new techniques and I got a valuable insight into working in an international team. I really enjoyed the scientific work and the many opportunities to develop myself. In addition,

I was fascinated by the various sport opportunities in the mountains. I loved to go hiking, sledding or expanding my cross-country skiing skills. And of course, I enjoyed the Swiss cheese and chocolate!



Surya Häne: Swiss Federal Institute of Technology, Zurich, Switzerland

ARI Project: **Treating Discogenic Pain by Reducing Nerve Sensitization and Ingrowth using the COX-2 Inhibitor Celecoxib – An *in vitro* Study with inflamed Annulus Fibrosus Cells (COX2IVD/Neurodisc2)**

I joined ARI for an internship and master thesis to acquire my master degree in biology with a major in molecular health sciences. The focus of my project is the degraded intervertebral disc in connection with the dorsal root ganglion cells, which are responsible for pain sensation. I enjoyed working on an inflammation model in human cells with people from different fields. Moreover, I really enjoyed

the nature in Davos for outdoor activities, such as hiking.



Johannes Hasler: Swiss Federal Institute of Technology, Zurich, Switzerland (country Liechtenstein)

ARI Project: **Developing osteogenic bioinks for bone regeneration (Bioink)**

I am a master student studying Health Science and Technology at ETH Zurich specializing in Medical Technology. I got a great possibility to gain experience in musculoskeletal regeneration by receiving the AO fellowship. As part of my internship and master thesis I was part of the Progenitor Cell Biology and Mechanoregulation group where I focused on different biomaterials to improve the differentiation of mesenchymal

stromal cells for bone regeneration. Together with improving my research skills, Davos offered me many opportunities for outdoor activities.



Katharina Keck: RWTH University, Aachen, Germany

ARI Project: **Biomechanical evaluation of the anchorage of two different screw blade fixation systems in proximal femur fractures**

I am studying medicine and joined the Biomedical Development Program for three months to work on my thesis. I really appreciated that I was given the opportunity to work in an interdisciplinary team that welcomed me warmly and was very supportive whenever I needed help. During my stay, I gained a lot of new knowledge and also spent a great time in the beautiful nature surrounding Davos. All in all, I really enjoy thinking back to this unforgettable experience.



Nadine Kluser: Swiss Federal Institute of Technology, Zurich, Switzerland

ARI Project: **Enhancing cartilage self-repair using cell free IPN biopolymer hydrogels (GelHome 2)**

I am currently finishing my master's degree in Health Sciences and Technology with a major in Medical Technology at the ETH Zurich. As part of my fellowship and master thesis, I joined the disc regeneration group. I focused on 3D printed angle-ply scaffolds for intervertebral disc regeneration. I enjoyed working in an interdisciplinary team and improved my research skills in the fields of regenerative medicine and tissue engineering. Furthermore, I loved the opportunity to combine the scientific work with my passion for mountain biking and skiing.



Nora Krejczinger: University of Veterinary Medicine, Budapest, Hungary

After graduating at the University of Veterinary Medicine in Budapest, I was wondering about traveling around the world to collect new experiences in veterinary medicine. As an intern, I took part in several projects. During my internship at the Preclinical Facility I learned the newest, and most precise protocols in anesthesia on different, "non-common" animals (i.e. mice, rats, rabbits and sheep). The fellows and the coworkers at the PCF took me into the orthopedic surgery and they taught me how to start new research programs, how to manage them and what kind of supplements are needed for performing these tasks. I was given

full responsibility of the postoperative treatment, therefore I had to make my own decisions on what actions should be taken. This made me braver and more independent at doing my job. Apart from working with the veterinarians, I had the possibility to help the animal care takers. Outside working hours, we had a lot of time to go hiking in the mountains around the city of Davos. The time spent at AO endeared me on the research aspects of veterinary medicine and the development parts of science. As a direct consequence I began pursuing a career on this field and was given a position as a laboratory veterinarian in my home country.



Wenye Li: Zhejiang University, Hangzhou, China

ARI Project: **Anti-inflammatory therapy for cartilage preservation**

I was lucky to have an opportunity for a summer internship in ARI in 2019 when I learned about the biomechanics and biochemistry for intervertebral disc degeneration studies, which introduced me to this excellent team. It is exciting to be back in 2020 to spend another 4 months on my bachelor's thesis. I am currently working on small herbal molecules that can protect 3D-cultured chondrocytes from inflammation and extracellular matrix loss, for which I will acquire knowledge and learn techniques in molecular and cellular biology, as well as improve my scientific thinking and research skills in orthopedics. My experiences at ARI provide me a great chance to be immersed in such a collaborative, inter-disciplinary, well-supported research organization, to be friends with scientists from different nations, and to enjoy the time in Davos in the best seasons.



Astrid Soubrier: Université Libre de Bruxelles, Brussels, Belgium
ARI Project: **NeuroDiscll – Better understanding of the link between neoinnervation of the intervertebral disc of the spine and back pain**

My internship at ARI has been a memorable experience. Through the internship research project within the IVD/CART group I got the very nice opportunity to discover the world of basic research. I was taught how to work in vitro and in ex-vivo culture models as well as how to perform specific cellular imaging techniques. I really appreciated the stay among people from different fields, all seeking together to improve patient care. Additionally, I certainly enjoyed the welcoming, open-minded and mutual

aid ambiance of the research institute and ... the outdoor environment.



Daphne van der Heide: University of Twente, Enschede, Netherlands
ARI Project: **Development of an *in vitro* fibrotic liver model**

During my time at ARI, I performed my master internship and had an amazing time as an ARI team member. I have had the opportunity to perform many aspects of prominent research, from polymer synthesis and characterization to cell culture studies within the Polymer group in the Musculoskeletal Regeneration Program. By conducting these many aspects of research, I acquired experience and skills by working together with surgeons, engineers and scientist, who also became close friends. Working at ARI together with people with a different expertise from all

different countries over the world has been professionally and personally a great learning experience.



Taiyo Yamamoto: Swiss Federal Institute of Technology, Zurich, Switzerland

ARI Project: **Syntesis of a tough double-network hydrogel based on extracellular matrix components for biomedical application**

I have spent seven months working on my master's thesis at the ARI in Davos. The time spent in the Polymers group was a very valuable experience. I have worked with biopolymers on the development of an ECM based tough hydrogel for cartilage tissue engineering. This having been my first 'real' research project, the work and exchange with motivated, competent and helpful supervisors and group members was a

very enriching experience. I am appreciative of the freedom given to me in my research and the trust I was given in pursuing my ideas and approaches. My time here in Davos has been very enriching both professionally and personally and I am grateful for this chance that has been offered to me through the collaboration of the ARI and ETH.

10 Remembering Prof Stephan M Perren



The passing of the globally acclaimed research scientist and AO founding father Stephan Perren on Wednesday, November 21, 2019, has inspired an outpouring of whole-hearted tributes from around the world.

"With Stephan's death, the AO lost its scientific backbone and founder. The AO community lost an inspiring teacher and mentor, and many, including myself, a warm personal friend. We will all miss him".

Chris van der Werken, AO Past President (2006-2008)

"We were so lucky to have such a great mentor with Stephan," said inventor and former ARI Research Associate (1983–1996) Slobodan Tepic.

"Stephan was a pioneer and a visionary man," added AO Trauma Europe and Southern Africa Board member Pol M Rommens, who initiated the Stephan Perren AO Trauma Research Traveling Fellowship. "He especially was a worldwide recognized and respected trauma researcher. I am happy and proud that I could start with the AOTrauma research fellowship, which bears his name. This and other initiatives will keep his achievements alive within the AOTrauma world."

Prof Pietro Regazzoni, an honorary AO Trustee since 1990, described his close friend and colleague Perren as "a pillar of the AO...but above all an extraordinary man."

"He has been and remains extraordinary, not only because the results of his research are now integral part of the manuals of musculoskeletal surgery," Regazzoni said. "Founder and research mastermind of our still unique AO Foundation, he is outstanding because of the spectrum of his personality. For a majority of his collaborators, he was not

only the director but a kind of paternal figure. This remained so even when they left the institute and after he left. His generosity and empathic leadership style were important ingredients. For an impressive number of surgeons, the rigor of scientific thinking was, is and will remain linked to the person of Stephan. His combination of thinking discipline and friendliness has been an important experience for many of his disciples."





AO founding member Thomas P Rüedi knew Perren since 1965 when they both served on Allgöwer's team at Kantonsspital Chur. Perren was a senior resident and Rüedi had just joined as a surgical trainee. Eight years later, after Perren had become head of the Laboratory for Experimental Surgery (now ARI), he was Rüedi's PhD mentor and coach for six months, providing unlimited enthusiasm and support as Rüedi wrote his thesis. In 1984, Perren, Peter Matter, and Rüedi were privileged to join the AO fathers - as a

second generation - in the creation of the AO Foundation.

"Under his leadership, ARI evolved to one of the world's best-known facilities in its field, attracting fellows from all continents," Rüedi said. "Until his very last days Stephan was still full of ideas in the search for new facts and explanations of the biological and biomechanical secrets of bone healing. Besides his research, he was a great teacher and mentor, an exceptional personality and a wonderful friend. His passing away is an enormous loss for research, the AO community and, of course, for his family and many close friends."

AO Past President (2000–2002) Prof Peter Matter and Perren trained together as surgeons under Allgöwer at Chirurgie Kantonsspital Chur, where Matter - as chief resident - was Perren's mentor. After Perren became director of the Laboratory for Experimental Surgery in Davos, those roles were reversed: Perren became the mentor from 1966–1967 while Matter did his University of Basel internship there.

"One of the very special adventures I had with Stephan was doing the very first classical sheep experiments to prove that fracture fragments put under pressure and fixed by a plate would not resorb bone," Matter said. He explained that the experiment used a strain gauge-mounted plate allowing continuous measurement of the pressure between bone fragments along the life of the sheep. "It proved our hypothesis: We had direct bone healing."

Like so many others in the AO universe, Matter pointed out Perren's immeasurable contributions to the advancement of patient care.

"Stephan Perren was a mentor to so many scientists from all over the world that it would be impossible to measure his influence," Matter said, adding that his friend's scientific prowess, kind spirit and commitment to mentorship made him a true champion.

"With the death of Stephan Perren, we have lost one of the great pioneers of the AO. Stephan took over the leadership of the AO Research Institute in the late 1960s. Almost from day he took over, he began to advance our knowledge about the relationship between bone healing and bone surgery. Not only a dedicated physician and an enthusiastic researcher, who never retired from working on innovative projects, Stephan was also a courageous pilot with many exploits to his credit. He was devoted to his family and a great friend to many. The AO community has lost one of its most distinguished members. He will be very much missed. I have lost a close friend and colleague, whom I admired for the past fifty years".

Joseph Schatzker, AO Past President (1988-2000), honorary AO member

Globally renowned for his strain theory explaining tissue deformation as a critical mechanical factor that controls bone healing, Perren was director of the ARI from 1967–1996. Lauded as an icon and a visionary, he is equally revered for his commitment to mentoring young researchers.

Perren, who is survived by his wife, Alice, and their four children, Dominic, Nicolas, Andreas and Peter, was born and raised in Zermatt, Switzerland. He attended high school in Schwyz before studying medicine at the University of Zurich, where he earned his diploma in 1960. He completed his thesis in 1965 at the University of Bern and, in 1987, received an honorary Doctor of Science degree from the University of Guelph in Canada.



He held honorary professorships at the University of Bern, Universidad de Montevideo in Uruguay, and the University of Wales Aberystwyth, UK. Over the course of his long career, Perren was a lecturer at the University of Basel, ETH-Zurich, the University of Bern, and Hong Kong University, and was an esteemed faculty member for AO courses in both Davos and abroad. He served at Regionalspital Visp (1960–

1961); Frauenklinik Winterthur (1962); Chirurgie Kantonsspital Chur, where he worked under AO Foundation cofounder Martin Allgöwer from 1962–1963 and 1966–1967; Thurgauisch-Schaffhausische Heilstätte Davos (1963–1964); and the Laboratory for Experimental Surgery Davos, known today as ARI, where he worked under director Herbert Fleisch (1964–1965).

When Fleisch accepted a professorship at the University of Bern, Perren took the leadership reins at ARI, serving as director until 1996. During that time, he moved ARI's research emphasis toward the mechanobiology of tissue repair, with a focus on the interaction of mechanical and biological influences on bone formation, remodeling, and healing. Under his leadership, important strides were made in internal fracture fixation, including the development of plates with limited and no contact with the underlying bone avoiding contact necrosis and tissue-friendly surgical procedures.

Perren was globally renowned for his strain theory explaining tissue deformation as a critical mechanical factor that controls fracture healing. After leaving ARI, he continued serving as a senior scientific advisor and active in research at ARI as recently as his last week.

"Stephan was a distinguished scientist whose work on bone mechanics and healing is world renowned," said ARI Director Prof Geoff Richards. "He was the scientific fundament of the AO Foundation's education which has influenced so many surgeons and his science also influenced many scientists in the musculoskeletal field and societies within this broad field. He was a very strong advocate of freedom to explore in research to allow discovery of real novelties that then could be developed and translated."

On a personal note, Richards called Perren "a true mentor, lifelong scientist, and friend."

"I am proud to have had my formative years here at AO with Stephan's guidance and recently over the last ten years having his long shadow watching from afar," he said.

In addition to his early role as director of AO, Perren was chair of the AO Technical Commission and Development Steering Committee for 16 years. Among his vast array of achievements were his 1972 invention of the Dynamic Compression Plate (DCP) and his 1992 invention of the Limited Contact Dynamic Compression Plate (LC-DCP) plate.

Additionally, Perren founded several well-known international societies, including the European Society of Biomechanics, where the AO Foundation has sponsored the ESB S.M. Perren Research Award since 2002, and the International Society for Fracture Repair. He was the recipient of a number of prestigious awards, including the AO Prize (1968), the 1983 Danis Prize presented by the Société Internationale de Chirurgie, the 1993 Johann Friedrich Dieffenbach bust from the Deutsche Gesellschaft für Unfallchirurgie (German Society for Trauma Surgery), the Association Internationale pour l'Ostéosynthèse Dynamique Award 2000 for the 100th birthday of Gerhard Küntscher, the 2001 Orthopedic Research Society Arthur Steindler, MD Award, and - in 2004 - the AO Prize for lifetime achievements.

In 2016 professor Perren became an OTA Honorary Member, which was a lovely gesture from OTA past president Ted Miclau who had been an ARI fellow in the early 90's and was mentored by Perren and remained friends until Perren passed away.

Furthermore, the Stephan Perren AO Trauma Research Traveling Fellowship, was established in his honor, providing young and enthusiastic researchers with a special interest in trauma care the opportunity to visit ARI and the Julius Wolff Institute for Biomechanics and Musculoskeletal Regeneration in Berlin, Germany for two weeks each. The fellowship drives forward Perren's legacy as both a researcher and a mentor to young researchers.



Stephan Perren with ARI AC chair and mentee Prof Ted Miclau

11 Project Abstracts by Sponsors

11.1 AOCMF

Biofunctional membrane for treatment of mandibular defect MASTICATE (Ongoing) (T Serra, D Eglin)

In clinical practice the development of guided tissue regeneration has considerably influenced the possibility of implant use in the jaw regions with bone defects and those with a bone anatomy that is unfavorable for implant anchorage. Membranes used for guided tissue regeneration are used in combination with bone grafts or bone graft substitutes to support vertical bone augmentation, growth and closure of periodontal soft tissue. Still, dehiscence- and fenestration-type defects persist in a significant percent of patients. This may be due to difficulty in achieving primary wound closure and suboptimal speed of soft and hard tissue healing as a result of the large volume to be revascularized, covered and repaired.

The overall aim of this study is to develop a dual layer membrane using a surface acoustic wave additive manufacturing technology with: 1) a bone layer made of assembled osteoconductive CaP microparticles into parallel lines in a collagen matrix (Figure 11.1.1) and 2) a soft tissue layer made of pre-assembled adipose tissue-derived microvascular fragments within a collagen matrix, for fast vascularization and bone healing.

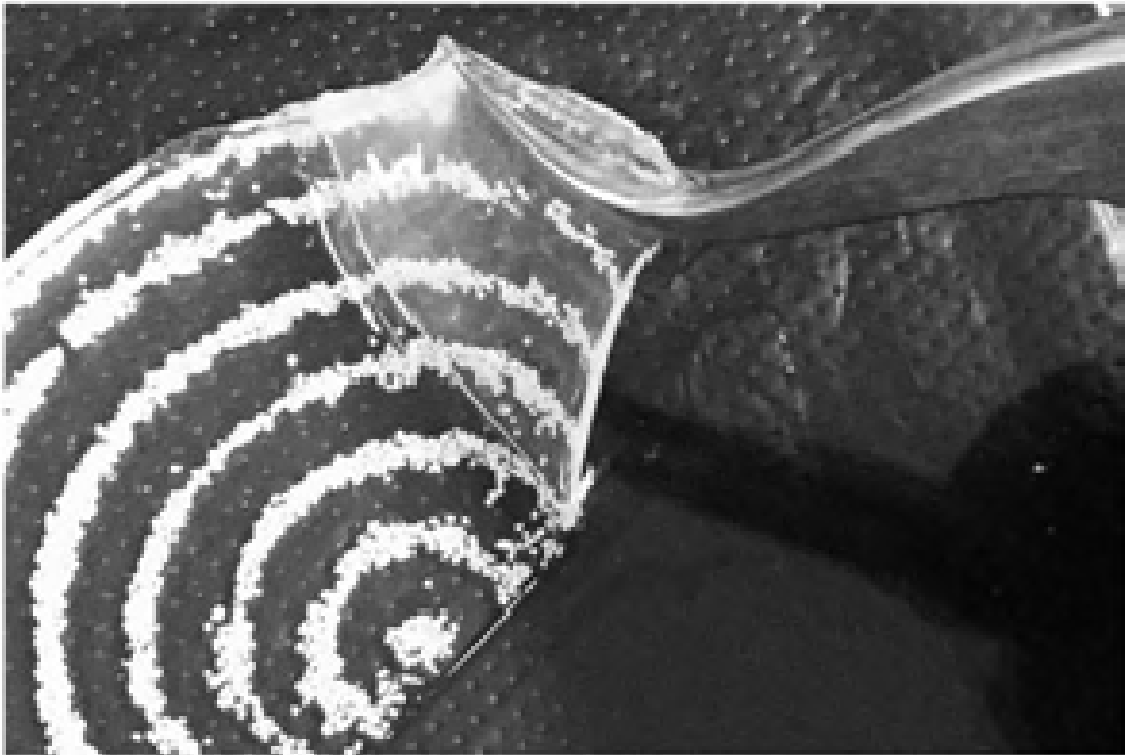

Figure 11.1.1. Example of gelatin-based hydrogel membrane loaded with a CaP particle pattern. Circular shape, diameter of 55 mm, easy handleable.

Inducing bone regeneration through immuno-modulation of biomaterials. RAIMBO Regeneration Immune Modulation Biomaterials (Ongoing) (M D'Este, D Eglin)

Bone repair in the craniomaxillofacial region is still a clinical challenge with a major impact on patients. For large defects after trauma or tumor resection, bone autografts are generally adopted as the clinical standard. However, this solution is far from ideal as donor site morbidity and the limited amount of material available impose limitations. Bone graft substitutes from natural or synthetic biomaterials would be a valid alternative, although their efficacy is hampered since they do not have the intrinsic healing properties of viable autologous bone. Additionally, they may still trigger deleterious immune responses, such as fibrous

encapsulation, resulting in impaired new bone formation and possibly even leading to implant rejection.

Adaptive and innate immune cells such as T cells, macrophages and neutrophils play a central role in modulating the immune responses to biomaterials used in the fabrication of implantable devices. While some general principles governing the immune response to implanted biomaterials topography and chemistry have been investigated, the consequences of interactions of 3D printed constructs with the host immune system remains mostly unknown. The systematic knowledge of how variations in shape, topochemistry and composition of 3D printed constructs interacts with the host immune system opens the possibility of modulating the immune response to biomaterials, and ultimately to improve bone healing. The overall goal of this project is to investigate the effect of specific material properties on immune cells such as neutrophils or macrophages. This will contribute to the design of biomaterials inducing a “healthy” inflammation in target clinical problems such as osteointegration; infection; fibrous encapsulation; osteolysis; implant rejection; new bone formation.

Experiments were performed to assess cell attachment, survival, LDH and reactive oxygen species production using a neutrophil-like cell line (PLB-985). LDH increased for collagen-THA in comparison to THA, and for PCL with surface topography rather than smooth (Figure 11.1.2). For validating the results, primary neutrophils from peripheral blood will be employed in the incoming experiments. For obtaining human blood, we applied for ethical approval at Swiss Ethics.

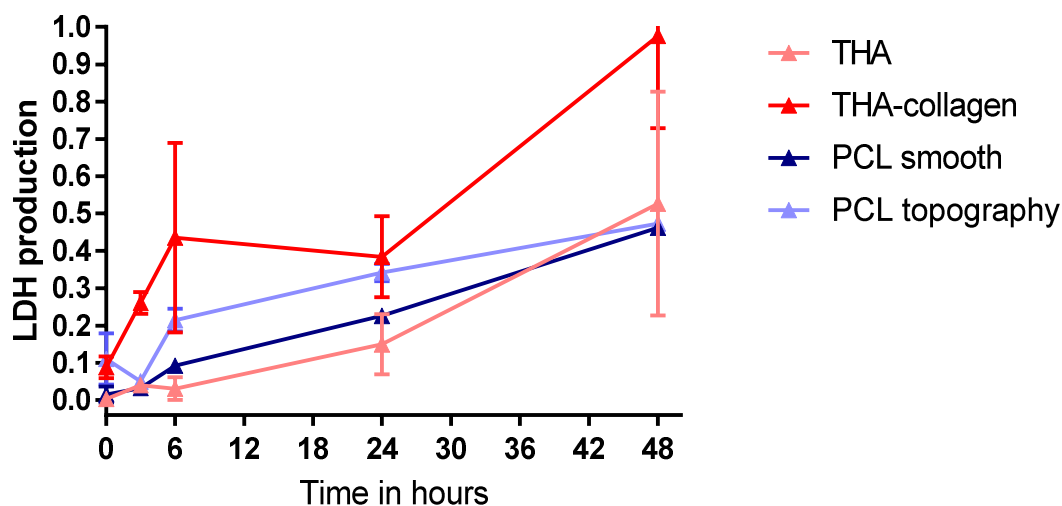

Figure 11.1.2: Plot of neutrophils LDH production seeded on different biomaterial surfaces overtime.

3D printing of cellularized tissue engineered constructs. Bioinks & Methods toward clinical translation (Bioink) (M Stoddart, D Eglin)

Background: Patient specific implants based on additive manufacturing principles hold great promise in CMF applications, where anatomical fidelity is paramount. As the imaging to printing workflows improve, one of the major remaining hurdles is the development of bioinks that are osteoinductive, while at the same time having a realistic path through regulatory approval. By avoiding complex material developments and following a "less is more" approach, we believe a novel material with clinical approval can be obtained more rapidly. This project investigated the printability of three clinically approved natural materials based on hyaluronic acid, fibrin and collagen. Further addition of Polyphosphate nanoparticles and dexamethasone releasing microparticles was investigated, with osteogenic differentiation the measured outcome. The potential to improve the gels osteoinductive properties by the addition of simple osteoinductive molecules that are already clinically approved would have a less challenging approval process.

Goal: To develop 3D printing of clinically relevant biopolymer hydrogel products, namely collagen type I, fibrin glue and hyaluronan for the manufacturing of cellular 3D osteogenic constructs.

Results: We have investigated several materials, with or without biological enhancers, for their bone forming capabilities both *in vitro* and *in vivo*. Surprisingly, the results of these assays often do not correlate, suggesting that current material testing algorithms are sub-optimal. Osteogenic differentiation was generally poor in all the materials tested, while polyphosphate addition appears to increase osteogenic differentiation *in vitro*. This project highlights the need for more suitable *in vitro* testing models for osteogenesis, in order to more accurately screen novel materials in the early stages of the development process.

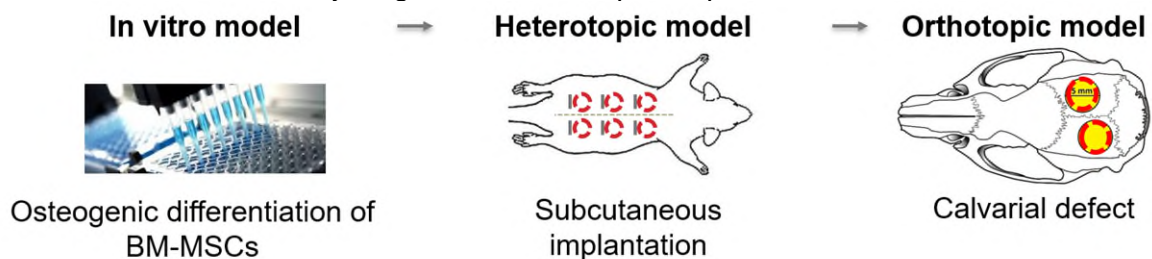

Figure 11.1.3: Schematic demonstrating the workflow used to test hydrogels for bone regeneration.

Pub:

Hatt LP, Thompson K, Müller WEG, Stoddart MJ, Armiento AR. Calcium Polyphosphate Nanoparticles Act as an Effective Inorganic Phosphate Source during Osteogenic Differentiation of Human Mesenchymal Stem Cells. *Int J Mol Sci.* 2019 Nov 18;20(22). pii: E5801. doi: 10.3390/ijms20225801.

Pres:

Hatt LP, Thompson K, Müller WEG, Stoddart MJ, Armiento AR. Calcium polyphosphate-nanoparticles act as an effective inorganic phosphate source during the *in vitro* osteogenic differentiation of human bone marrow-derived MSCs. 2019 SBMS (oral)

Partner:

- Werner E G Müller (Prof) Institute for Physiological Chemistry, University Medical Center of the Johannes Gutenberg University, Mainz, Germany

11.2 AOSpine

Annulus fibrosus repair (IVDAFR) (Z Li, S Grad)

Background: Appropriate cell sources, bioactive factors and biomaterials for generation of functional and integrated annulus fibrosus (AF) tissue analogues are still an unmet need.

Goal: To induce a functional cell population from AF cells for enhanced AF extracellular matrix (ECM) synthesis and repair.

Results: Supplementation of TGF- β 1 upregulated gene and protein expression of several AF cell markers in human mildly degenerated AF cells and increased cell contractility, indicating that TGF- β 1-pre-treated AF cells may be an appropriate cell source for AF tissue engineering or AF rupture repair. Collagen type I hydrogel as a cell carrier maintained the phenotype of human AF cells. TGF- β 1 treatment within the collagen hydrogel further promoted cell proliferation and matrix production of AF cells both *in vitro* and *ex vivo*. In a bovine intervertebral disc organ culture model, TGF- β 1 containing collagen type I hydrogel-polyurethane scaffold hybrid system retained the AF phenotype of implanted cells. These constructs have potential for generating tissue engineered AF and warrant further investigation for their use in repairing AF defects after discectomy.

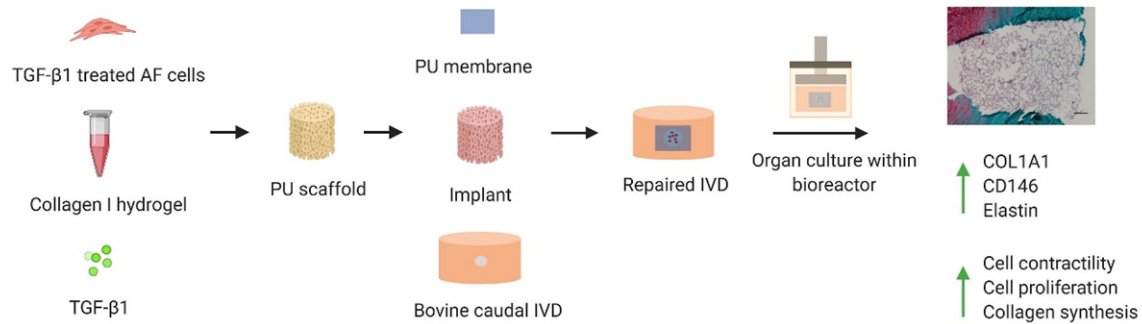

Figure 11.2.1: Functional cell phenotype induction with TGF-β1 and collagen-polyurethane scaffold for annulus fibrosus rupture repair

Pres:

Du J, Long RG, Sakai D, Benneker LM, Iatridis JC, Alini M, Grad S, Li Z. Cell seeded collagen-polyurethane scaffold supplemented with TGFβ for annulus fibrosus repair. 2019 TERMIS EU (oral)

Li Z. Annulus fibrosus repair with endogenous cell activation and function inducing cell transplantation. 2019 ICORS (oral)

Li Z, Du J, Long RG, Sakai D, Benneker LM, Iatridis JC, Alini M, Grad S. Functional cell phenotype induction with TGFβ1 and collagen-polyurethane scaffold for annulus fibrosus repair. 2019 ORS PSRS (poster)

Pub:

Long RG, Ferguson SJ, Benneker LM, Sakai D, Li Z, Pandit A, Grijpma DW, Eglin D, Zeiter S, Schmid T, Eberli U, Nehrbass D, Di Pauli von Treuheim T, Alini M, Iatridis JC, Grad S. Morphological and Biomechanical Effects of Annulus Fibrosus Injury and Repair in an Ovine Cervical Model. JOR Spine 2019, e1074.

Partners:

- Sakai D (Prof), Tokai University School of Medicine, Isehara, Japan
- Benneker LM, (Prof), Inselspital, University of Bern, Bern, Switzerland
- Iatridis JC (Prof), Icahn School of Medicine at Mount Sinai, New York, NY
- Pandit A (Prof), CURAM, National University of Ireland, Galway, IRL

11.3 AOTrauma

The influence of temporal fracture mechanics modulation on bone healing (ActiveFix) (J Barcik, M Ernst, M Windolf)

Background: Despite decades of research on mechanobiology of fracture repair, certain aspects in the field remain untouched. Especially the impact of temporal variation of mechanical stimulus is only barely understood. However, there might be huge potential in the field to improve speed and robustness of healing. Recent preclinical experiments (ImpCon2 Project) suggest that fracture stimulation in an early post-operative phase could be of high importance for robust and timely healing. This important matter should be further investigated. Goal: A recently introduced experimental two-defect preclinical fracture model (QUT, Brisbane, Australia), implementing an actuator-driven external fixator, allows executing arbitrary stimulation protocols to the fracture site completely independent from functional loading. This implant system will be improved and adapted to the needs of this project and applied *in vivo* comparing immediate to delayed fracture stimulation.

Results: To enable programming and execution of arbitrary stimulation protocols with the fixator, a dedicated controller was developed and implanted along with the QUT system in 10 Swiss White Alpine sheep randomized in two groups (n=5). The device was programmed to execute an immediate post-operation stimulation protocol for the one of the groups and a 3-week delayed stimulation protocol for the other. In this experimental setting, no significant difference was observed between the groups in terms of healing competence, which might be related to a vascular impairment at the fracture site. However, the developed model enabled continuous monitoring of both the healing progression and short-term response of the healing tissue to strain stimuli over hours and days. The results highlight the importance of resting times during fracture healing. The impact of temporal variations in mechanical fracture stimulation (immediate versus delayed) on bone healing will be further investigated.

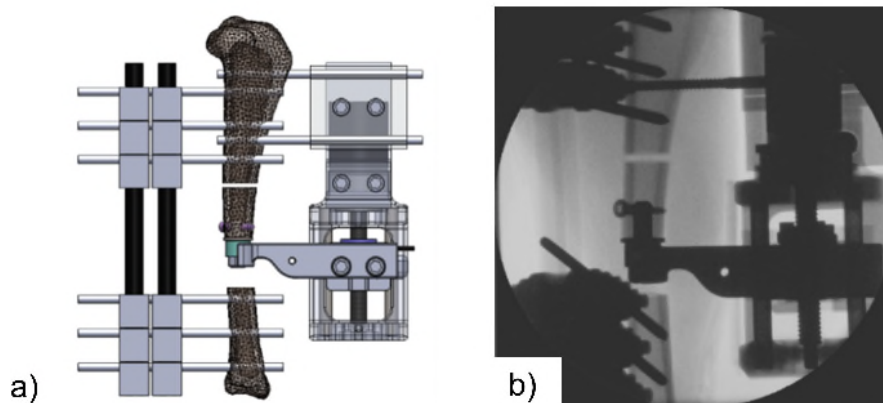

Figure 11.3.1: CAD model (a) and X-Ray (b) illustrating actuated external fixator implanted in sheep tibia.

Pres:

Barcik J, Ernst M, Freitag L, Dlaska C, Drenchev L, Gueorguiev B, Skulev H, Mys K, Epari D, Windolf M. Automated active fixation system to test the influence of different loading regimes on fracture healing. 2019 ESB Vienna, 07.-09.2019 (poster).

Barcik J, Ernst M, Schwyn R, Freitag L, Dlaska C, Drenchev L, Todorov S, Gueorguiev B, Skulev H, Epari D, Windolf M. Development of tailor-made equipment for experimental preclinical surgeries using computer simulations and 3D printing. 2019 ICMCC, Varna, 25.-27.09.2019 (oral).

Barcik J, Ernst M, Balligand M, Dlaska CE, Drenchev L, Todorov S, Gueorguiev B, Skulev H, Zeiter S, Epari D, Windolf M. Continuous monitoring of fracture healing to analyze short-term response of bone repair tissue to mechanical stimulation. 2019 EORS, Maastricht, 02.-04.10.2019 (oral).

Barcik J, Ernst M, Freitag L, Dlaska CE, Drenchev L, Todorov S, Gueorguiev B, Skulev H, Zeiter S, Hofman-Fliri L, Epari D, Windolf M. Automated electromechanical system designed to investigate the effect of local mechanical conditions on fracture healing progression. 2019 EORS, Maastricht, 02.-04.10.2019 (oral).

Barcik J, Ernst M, Freitag L, Dlaska CE, Drenchev L, Todorov S, Skulev H, Zeiter S, Epari D, Windolf M. Automated active fixation system designed to investigate the influence of local mechanical environment on fracture healing. 2019 TERMIS-AP + ABMC7, Brisbane, 14.-17.10.2019 (poster).

Barcik J, Ernst M, Balligand M, Dlaska CE, Drenchev L, Todorov S, Skulev H, Zeiter S, Epari D, Windolf M. Analysis of the short-term response of fracture repair tissue to mechanical stimulation. 2019 TERMIS-AP + ABMC7, Brisbane, 14.-17.10.2019 (poster).

Partners:

- Epari D (Prof), Queensland University of Technology (QUT), Brisbane, Australia
- Dlaska CE (MD), Orthopaedic Research Institute of Queensland, Townsville, Australia
- Balligand M (Prof), University of Liège, Belgium

A novel concept for guided growth regulation (GoForce) (J Buschbaum, M Windolf)

Background: Corrections of limb deformities, in particular varus-valgus and leg length discrepancies are frequent interventions in pediatric orthopedic surgery. Depending on the severity, deformities can be balanced by temporary epiphysiodesis, where the growth is guided by blocking the physis. Currently utilized implants have their disadvantages, being not 'passively' safe and requiring timely surgical removal, as sustained growth leads to steady rise of the implant reaction force, resulting in such devastating events as implant-related failures or unwanted permanent physeal growth plate closure due to over-excessive forces. A novel 'passively' safe implant concept was developed applying growth independent constant compression force to the physis, hypothesized to provide safe, reliable and controllable treatment.

Goal: To test the functionality and efficacy of the proposed implant concept in a large animal model.

Results: Thirty-six lambs were equipped with the proposed implant in order to create either varus-valgus deformities (phase 1, 18 lambs) or leg length discrepancies (phase 2, 18 lambs). They were assigned to 3 groups per phase considering 3 implant force levels (60 N, 120 N and 200 N). Changes in the medial proximal tibial angle (phase 1) and the developed differences in tibia length (phase 2) were assessed from biweekly radiographs.

The results show that the proposed implant concept enables safe and controlled growth regulation. Significantly different correction rates were achieved, depending on the applied force levels. Most efficient was the 200 N implant, followed by the 120 N one. Only marginal effect was observed for the 60 N implant. The correction rates remained constant over the treatment period, thus highlighting advantages with regard to more reliable treatment planning. No implant related failures were observed, underlining the passive concept safety. The concept revealed potential for clinical translation. Apart from the medical device development aspects, the results provide new important scientific information enhancing both the knowledge on bone growth processes and treatment of limb deformities.

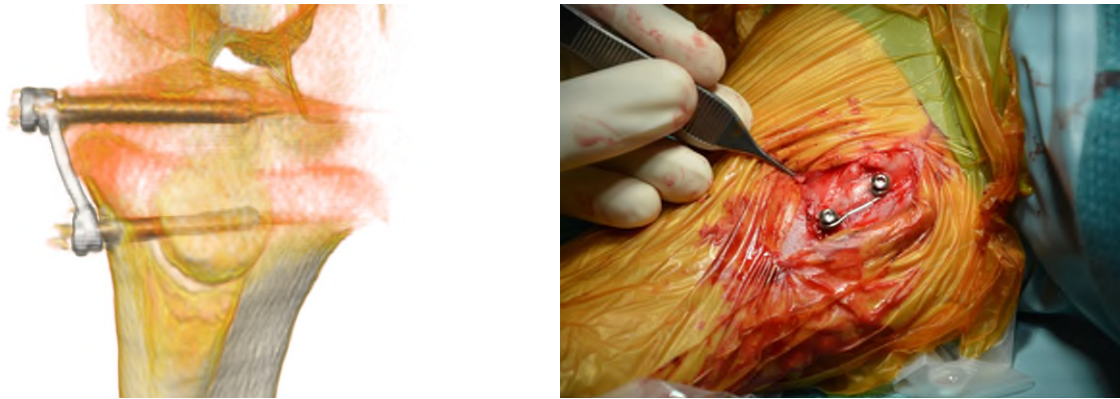

Figure 11.3.2: Utilized constant-force implant in a hemi-epiphysiodesis setting.

Partner:

- Slongo T (MD) Children’s University Hospital, Berne, Switzerland

Method for creating a statistical form model of the distal radius cortical bone geometry (corticalSFM) (H Noser, B Gueorguiev, L Kamer)

Background: Detailed knowledge about the cortical bone geometry and thickness can be used for many applications within orthopedic and trauma care. Three-dimensional (3D) image data, contemporary image processing and analysis as well as Artificial Intelligence techniques could be used for complex bone models to be efficiently generated and analyzed. Such models potentially enable generation of information relevant for clinical applications, research and development, or educational purposes. The generation of highly accurate bone models for the distal radius is of interest.

Goal: To develop a method for generation of a highly accurate 3D statistical model of the distal radius and a learning system to assess its osteoporosis status.

Results: Using 60 high-resolution peripheral quantitative computed tomography (HR-pQCT, 82µm image resolution) scans of the distal radius, a highly accurate 3D statistical cortical bone model of the latter has been successfully generated. In addition, an accurate learning system (accuracy 98.3%, AUC values > 0.96) has been developed and validated using 10-fold cross-validation. It allows to determine the osteoporosis status based on thickness data at given locations.

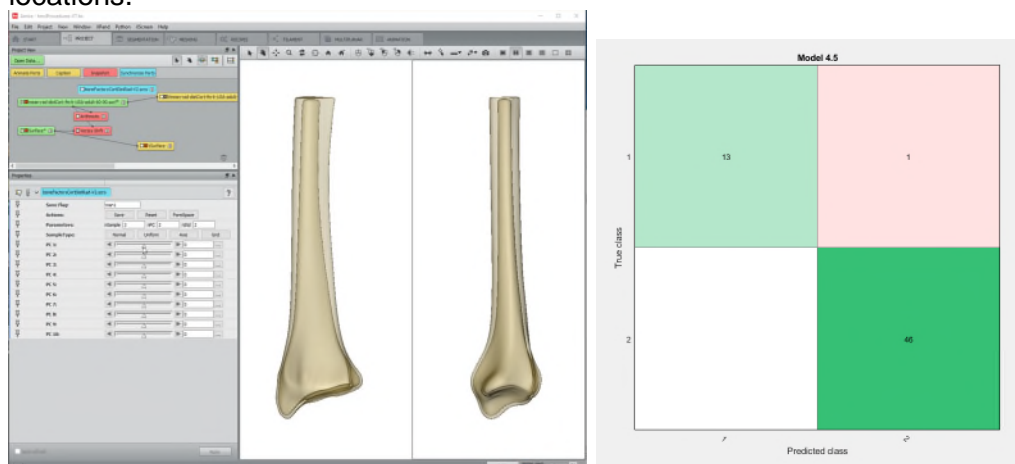

Figure 11.3.3: Software script object to visualize the 3D statistical cortical bone model of the distal radius (left). Analysis of the osteoporosis learning system (confusion matrix with the number of observations; Quadratic Discriminant Classification learner) (right).

Partner:

- Teunis T, (MD) University Medical Center Utrecht, Netherlands

Symmetry analysis of the pelvic ring (SymPel) (K Handrich, H Noser, L Kamer)

Background: The human pelvis represents a complex anatomical structure consisting of the sacrum, coccyx and innominate bones forming the pelvic ring. In general, it displays a symmetric configuration with the mid-sagittal plane separating the pelvic ring into an ipsilateral and contralateral side. Each of the two sides is considered as a mirror image.

Pelvic ring symmetry is an important item for consideration in orthopedic surgery and trauma care analysis. It can be used to study symmetry patterns in clinical cases, eg., to assess malformations, degenerative changes and fractures, or for preoperative planning, as well as for fabrication of individualized, patient-matched implants for research.

Goal: To demonstrate the feasibility of symmetry analysis of the pelvic ring using CT scans. In particular:

- To evaluate different possible methods for symmetry analysis of the pelvic ring
- To identify anatomical regions of the contralateral pelvic ring which can be taken as a reference to estimate the anatomy of the ipsilateral side
- To define a clinically feasible workflow for symmetry analysis of the pelvic ring in a given CT case

Results: A series of 150 pelvic CT scans (50 European females and 50 males, 20 Asian females and 30 males) were post-processed with gender and ethnicity specific 3D statistical models of the pelvic ring generated.

A workflow for symmetry analysis has been elaborated for identification of symmetry patterns in given analysed CT cases. The pelvic ring analysis resulted in a symmetric complex configuration with regard to the bony surface and its internal configuration. Distinct anatomical sites were identified where asymmetry patterns were typically located.

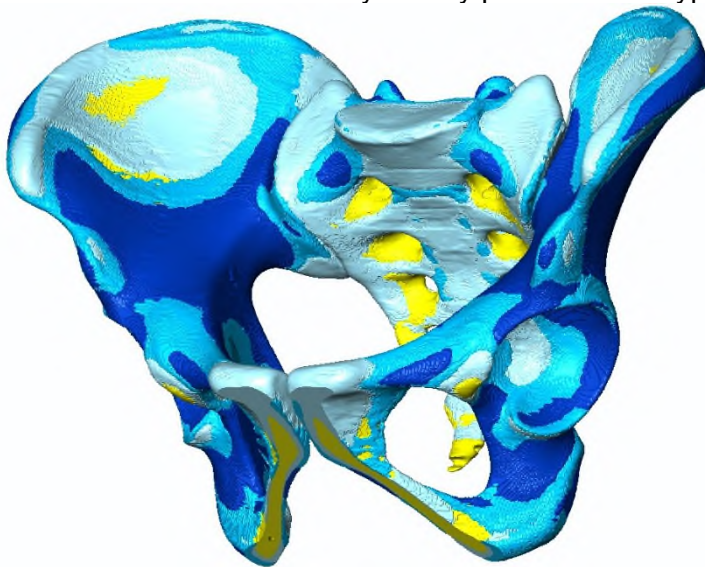

Figure 11.3.4: CT based 3D statistical pelvic model illustrating bone mass distribution with maximum (dark blue), intermediate (blue), low (light blue) and minimum (yellow) values. Maximum values predominantly located in innominate bones, minimum values mainly in sacrum and symphysis (cross section).

Partners:

- Rommens PM (Prof), University Medical Center, Mainz, Germany
- Mayo K (Prof), University of Washington School of Medicine, Seattle, USA
- Sawaguchi T (Prof), Toyama Municipal Hospital, Toyama, Japan
- Arand C (MD), University Medical Center, Mainz, Germany
- Wagner D (MD), University Medical Center, Mainz, Germany

Biomechanical evaluation of a new concept for screw-in-screw fixation of fragility sacrum fractures (SacrumFix) (I Zderic, B Gueorguiev)

Background: Surgical treatment of fragility sacrum fractures with percutaneous sacroiliac (SI) screw fixation is associated with high failure rates of screw loosening, cut-through and turn-out. The latter is a common cause for complications, being detected in up to 14% of the patients.

Goal: To develop a new screw-in-screw concept and prototype implant for fragility sacrum fracture fixation and test it biomechanically versus transsacral and SI screw fixations.

Results: Twenty-seven artificial pelvises with discontinued symphysis and a vertical osteotomy in zone 1 after Denis were assigned to 3 study groups, fixed with either a transsacral screw, a SI screw, or the new screw-in-screw implant, and biomechanically tested using validated setup and test protocol for application of complex axial and torsional loading to failure. Interfragmentary movements and implant motions in terms of pull-out, cut-through, tilt, and turn-out were significantly higher for SI screw fixation compared to both transsacral screw and screw-in-screw fixations. In addition, transsacral screw and screw-in-screw fixations revealed similar construct stability. Moreover, screw-in-screw fixation successfully prevented turning-out of the implant, that remained at 0° rotation around the nominal screw axis during testing for all specimens.

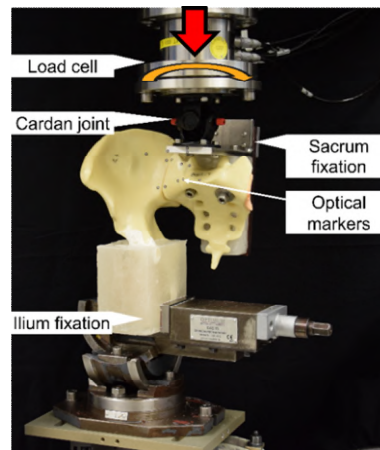

Figure 11.3.5: Test setup with a specimen mounted for biomechanical testing. Vertical and semi-circular arrows show loading directions.

Partners:

- Acklin Y (MD), University Hospital Basel, Basel, Switzerland
- Rommens P (Prof), University Medical Center Mainz, Mainz, Germany
- Wagner D (MD), University Medical Center Mainz, Mainz, Germany

Predicting patient-specific mechanical failure of proximal humerus fracture plating with computer simulations (SystemFix II) (Ongoing) (P Varga, D Mischler, M Windolf)

Background: The high failure rate of osteoporotic proximal humerus fracture fixations and the expected increase of their incidence indicate the need for improved fixation strategies and careful planning. Validated computer models have high potential to complement or partially replace conventional biomechanical testing, expedite implant optimization and design, refine surgical guidelines, support decision making and allow patient-specific preoperative planning. Ultimately, simulations are expected to help improve patient outcomes of osteoporotic proximal humerus fracture treatment. In the previous (first) project phase, a virtual osteosynthesis test kit was developed to simulate proximal fracture plating and predict mechanical fixation failure. This tool was validated experimentally and utilized in a series of virtual pilot studies to indicate ways of improving plate applications, to compare different implants, and to optimize implant design towards improved stability. However, the models have not yet been demonstrated to predict mechanical fixation failure in real clinical cases.

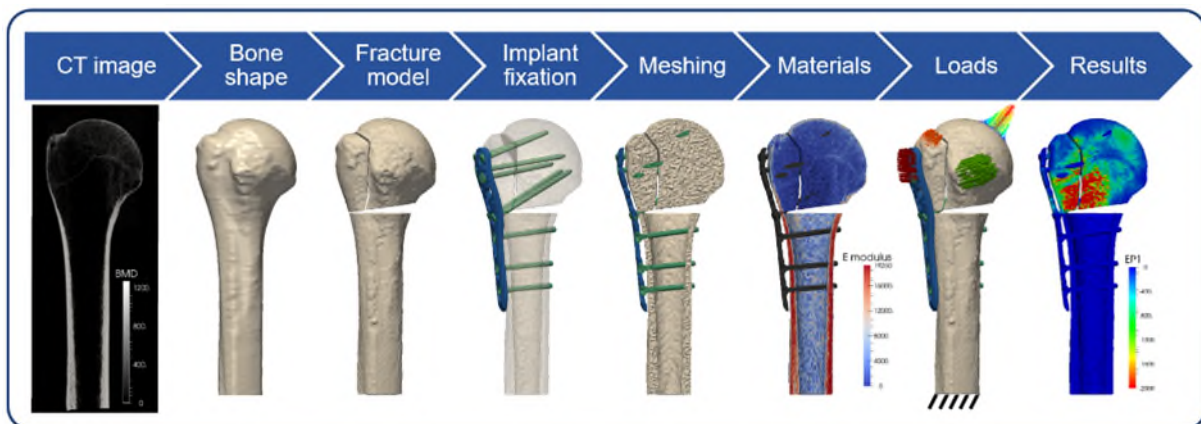

Figure 11.3.6: Illustration of the digital workflow implemented in the virtual osteosynthesis test kit.

Goal: To extend the osteosynthesis test kit application from virtual to real clinical scenario and validate it clinically by predicting the patient-specific risk of mechanical fixation failure.

Results: Clinical data collection has been successfully started at both study sites Leuven (Belgium) and Innsbruck (Austria). Six out of the planned 40 patients with PHILOS-plated proximal humerus fractures have been recruited so far. The methodology for creation of subject-specific computer simulations from clinical data is under development with implementation of individual post-operative shoulder activities evaluated from sensor data. To strengthen the biomechanical relevance, two experimental sub-studies have been performed to investigate the effect of both screw length and pilot-hole overdrilling on cyclic screw perforation in unstable proximal fractures fixed with locked plates. With the use of this data, the validity of the simulations is extended from the previously investigated cut-through failure to secondary screw perforation. A first validation study has demonstrated that finite element analysis can provide a highly accurate prediction of single screw perforations through the humeral head. Several sub-studies have been published in this project phase, utilizing the virtual osteosynthesis test kit in in-silico trials to investigate selected aspects of locked plating of proximal humerus fractures.

Pub:

Fletcher JWA, Windolf M, Richards RG, Gueorguiev B, Buschbaum J, Varga P. The importance of locking plate positioning in proximal humeral fractures as predicted by computer simulations. *J Orthop Res.* 2019;37(4):957-964

Fletcher JWA, Windolf M, Grünwald L, Richards RG, Gueorguiev B, Varga P. The influence of screw length on predicted cut-out failures for proximal humeral fracture fixations predicted by finite element simulations. *Arch Orthop Trauma Surg.* 2019;139:1069-1074

Fletcher JWA, Windolf M, Richards RG, Gueorguiev B, Varga P. Screw configuration in proximal humerus plating has a significant impact on fixation failure risk predicted by finite element models. *J Shoulder Elbow Surg.* 2019;28(9):1816-1823

Ciric D, Mischler D, Qawasmi F, Wenzel L, Richards RG, Gueorguiev B, Windolf M, Varga P. Secondary Perforation Risk in Plate Osteosynthesis of Unstable Proximal Humerus Fractures: A Biomechanical Investigation of the Effect of Screw Length. *J Orthop Res.* 2019;37(12):2625-2633

Panagiotopoulou VC, Varga P, Richards RG, Gueorguiev B, Giannoudis PV. Late screw-related complications in locking plating of proximal humerus fractures: A systematic review. *Injury.* 2019;50(12):2176-2195

Pres:

Fletcher J, Windolf M, Gueorguiev B, Richards RG, Varga P. SystemFix – Using computer simulations to optimise proximal humeral fracture fixation. 2019 ICORS (oral)

Fletcher J, Windolf M, Richards RG, Gueorguiev B, Varga P. Optimising proximal humerus fracture plating – discoveries from computer simulations. 2019 LSM (poster presentation prize)

Mischler D, Windolf M, Varga P. Computational optimization of the locking screw angles of a proximal humerus plate. 2019 ESBioMech (oral)

Wenzel L, Ciric D, Mischler D, Qawasmi F, Gueorguiev B, Richards RG, Windolf M, Varga P. Biomechanical investigation of the effect of screw length on screw perforation in unstable 3-part osteoporotic proximal humerus fractures. 2019 DKOU (oral)

Mischler D, Schader J, Windolf M, Varga P. Improving fixation techniques of proximal humerus fractures by means of finite element analysis. 2019 EORS (oral)

Ciric D, Mischler D, Qawasmi F, Wenzel L, Windolf M, Gueorguiev B, Varga P. Longer screws do not increase perforation risk in plating of complex proximal humerus fractures in vitro. 2019 ESBioMech (oral)

Ciric D, Mischler D, Qawasmi F, Windolf M, Gueorguiev B, Varga P. Predicting cyclic screw perforation in complex proximal humerus fracture plating. 2019 ESBioMech (oral)

Theses:

Ciric D. The risk of secondary screw perforation in plate osteosynthesis of unstable proximal humerus fractures: prediction and the effect of screw length. Master Thesis, Flinders University, 2019.

Burkhard B. Experimental and computational investigation of the risk of overdrilling on the biomechanical competence of proximal humerus plating. Master Thesis, Swiss Federal Institute of Technology Zurich (ETHZ), 2019.

Partners:

- Nijs S (Prof), University Hospital Leuven, Belgium
- Hengg C (MD), Medical University Innsbruck, Austria

Exopolysaccharide coated material surfaces modulating fracture immune status and enhancing bone healing (EPSIm) (Ongoing) (F Moriarty, K Thompson, D Eglin)

One of the most challenging complications in trauma surgery is fracture related infection (FRI). In chronically infected non-unions, treatment always includes extensive debridement to remove necrotic and infected bone, often resulting in large defects requiring elaborate and prolonged bone reconstruction techniques. There is a perception in the clinical community that in the patients with a chronically infected non-union compared to patients requiring acute resection due to trauma or osteosarcoma (non-infected) poorer repair is achieved. In patients, it is known that compromised immune status can delay bone healing. In experimental studies it was seen that bone repair can be compromised in animals previously infected compared with non-infected equivalents. In trauma patient treated for infection, it is likely that the immune status of the wound is such that the normal healing cascade is deregulated, leading to slower and suboptimal recovery. Therefore, reinstalling a normal or pro-healing immune status after treatment of a bone infection may positively impact the speed of bone healing.

In this project, we aim to reinstall an immunocompetent fracture milieu via the locally delivery (implant coating) of an immune-modulating exopolysaccharide (EPS) secreted by commensal microbe Bifidobacterium which has shown to increase anti-inflammatory (immunoregulatory) cytokine secretion, which we propose will reduce the pro-inflammatory environment present in an infected wound (Figure 11.3.7).

Figure 11.3.7: Schematic of the project hypothesis.

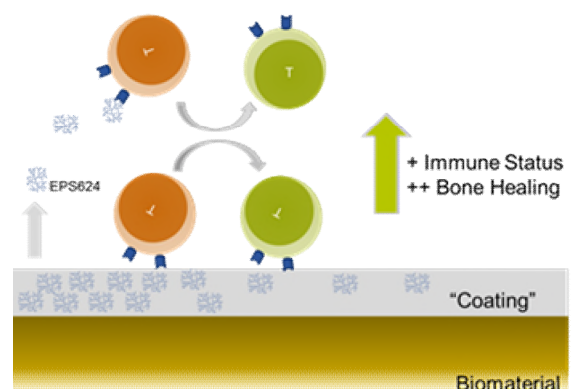

Immunoprofiling of fracture patients to determine predictive biomarkers of healing (NUPredict) (Ongoing) (K Thompson, M Stoddart, M Alini)

Background: Delayed healing and potential progression to non-union continues to remain a clinical issue in the context of fracture repair. Although it is currently possible to identify patient groups at risk of healing complications, such as diabetics and smokers, currently it is not possible to identify specific patients at elevated risk of delayed healing. Recent studies have suggested that alterations in the specific populations of immune cells may contribute to inappropriately maintained inflammation that detrimentally affects fracture healing capacity in such patients. These immune cell changes typically appear to boost pro-inflammatory cytokine production, either through increased proportions of effector cells (such as CD8 T cells), or via a failure of regulatory immune cells (including regulatory T- and B- lymphocyte subsets) that seek to diminish effector cell function and cytokine production. However, the majority of these reported studies are hampered by limited sample numbers as well as a failure to thoroughly interrogate the immune cell profiles of these delayed healing patients. In addition, the contribution of intercellular signalling, mediated via microRNA (miRNA) resident in extracellular vesicles, to the diminished healing capacity is currently unknown. This raises the exciting possibility that blood-resident factors could provide early clues regarding diminished fracture healing and could thus, if identified, be used as a therapeutic biomarker to aid early intervention in such patients.

Goals: To conduct detailed phenotyping of immune cells resident in delayed healing patients compared to normal healing patients, in an attempt to determine the defect(s) in immune cell function contributing to delayed healing. In addition, we seek to determine if miRNA resident in extracellular vesicles present in the blood can identify patients at risk of diminished healing and thus potentially be used as a predictive biomarker for healing outcome.

Results: To date we have focused on obtaining a cohort of suitable patients with which to address our overall aims of the study. Mononuclear cells isolated from the peripheral blood (PBMCs) of patients suffering from delayed healing, as well as PBMCs from patients displaying normal healing capacity, are isolated and are cryopreserved until satisfactory numbers (≥ 10 delayed healing patients) have been recruited. Serum is also collected from these patients, which we will use to analyze the levels of pro- and anti-inflammatory cytokines/chemokines, and from which to isolate the extracellular vesicles containing the miRNA cargoes of interest. Using the obtained data from the immune cell profiling and serum analysis we will compare if delayed healing patients display distinct profiles that differ from an age- and sex-matched cohort of normal healing fracture patients. Should such a potential biomarker be proposed from this series of investigations we will then aim to test the specificity and sensitivity of such a predictive biomarker in future clinical studies.

Partner:

- Akdis C (Prof), Swiss Institute of Allergy and Asthma (SIAF), Davos, Switzerland

miRNA analysis to discover fracture related biomarkers (MiDiag) (M Stoddart, M Alini)

Background: Biomarkers predictive of fracture healing outcomes would provide a useful tool to allow surgeons to proactively make patient based clinical decisions. Currently, even in high risk groups, there are no accurate ways to determine the potential of a particular patient to progress to delayed or non-union. Such a tool would enable more reliable patient stratification, thus allowing for earlier diagnosis and increasing the potential success of additional early interventions by the surgeon. Small non-coding RNA sequences, such as microRNA (miRNA) have been shown to be powerful regulators of cellular behavior in both healthy and diseased environments. They can function by interacting with messenger RNA sequences and thereby modifying protein expression. miRNAs normally act intracellularly, but due to the action of extracellular vesicles (EVs) released by cells they are able to signal over large distances and thus EVs are a critical signaling pathway between different cells. EVs and miRNA have the advantage of being extremely stable, detectable in complex body fluids such as serum, and provide information directly relating to cellular function. MicroRNA (miRNA) studies are already

transitioning from basic research applications to clinical applications in areas such as cancer diagnosis.

Goal: Within this project we aim to identify fracture related non coding RNA sequences, present in extracellular vesicles, in the serum of patients. Then establish their function within primary human mesenchymal stem cells and propose predictive markers that could be used to screen patients early after injury. In addition, functionally active miRNA species identified as lacking in non-healing patients can also be used as a potential off-the-shelf treatment to enhance fracture repair in patients shown to have a decreased level of expression.

Results: Serum was obtained from patients at various times after injury day 0-3, day 5-12 and day 19-56 and whole non-coding RNA was sequenced. As a comparator, mesenchymal stromal cells (MSCs) were induced to undergo osteogenesis and compared to unstimulated controls. We have identified several miRNA targets that are regulated during early osteogenesis. We also identified the presence of some of these markers in serum taken from fracture patients within days after fracture (Figure 11.3.8).

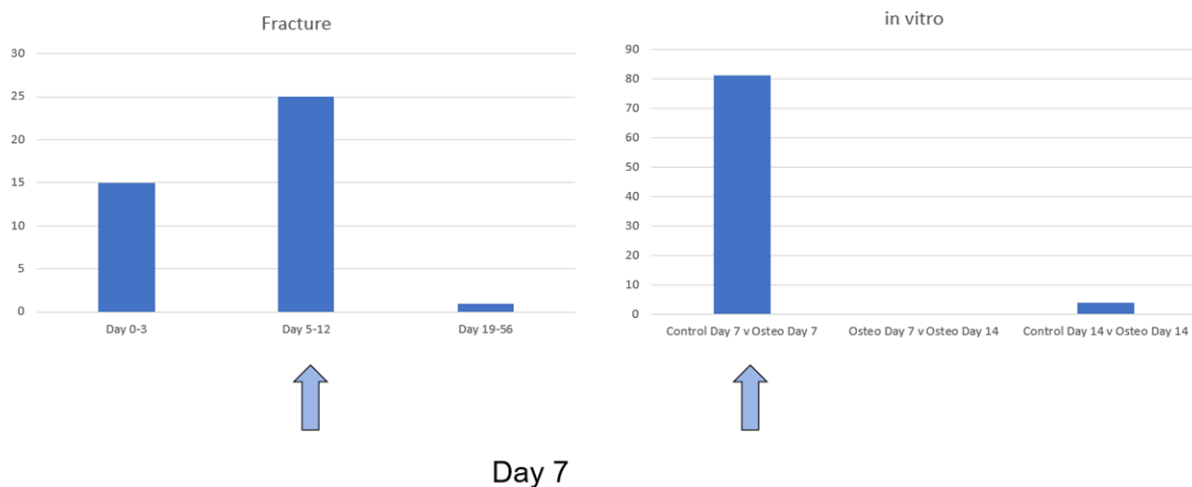

Figure 11.3.8: Number of miRNA markers differentially regulated between fracture patients and healthy controls (left), and osteogenic MSCs versus control cells (Right). In both case the greatest number of changes were observed around 1 week.

Furthermore, we are also one of the first groups to identify piRNA and circular RNA markers of osteogenesis. This work will be continued in a new follow up project.

Pub:

Della Bella E, Stoddart M. Cell detachment rapidly induces changes in non-coding RNA expression in human mesenchymal stromal cells. *Biotechniques*. 2019 Oct 17. doi: 10.2144/btn-2019-0038

Partner:

- Kubosch J (MD), Albert-Ludwigs University Medical Center Freiburg, Germany

The influence of the gut microbiota on bone (BacBone) (K Thompson, F Moriarty)

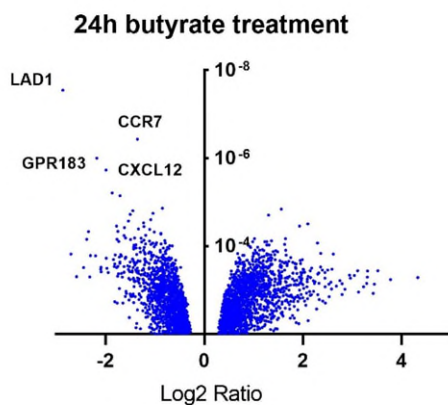

Figure 11.3.9: Volcano plot displaying differential expressed genes (blue dots) following 24h of butyrate

Differential expressed genes involved in osteoclast formation

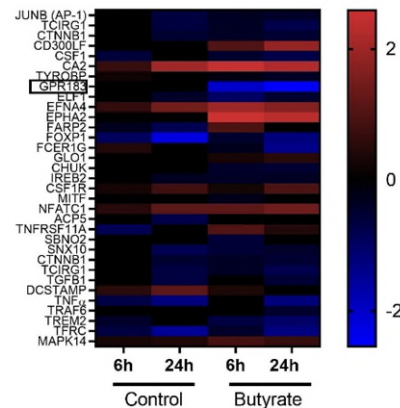

Figure 11.3.10: Heatmap showing differential expressed genes involved in osteoclast formation

It has become increasingly evident that the gut microbiota plays a crucial role in many diseases, including bone-associated morbidities, such as osteoporosis, and possibly also fracture healing.

In this project, we are investigating the impact of the gut microbiota on bone in health and during a fracture related infection.

One way the gut microbiota interacts with bone is through production of metabolites, especially short-chain fatty acids (SCFAs). Butyrate is one class of SCFAs and we found, that butyrate (C4) inhibits murine, as well as human osteoclast formation in vitro. We performed RNA sequencing of osteoclast precursor cells treated with butyrate to identify differentially expressed genes, which may play a role in the butyrate mediated inhibition of osteoclastogenesis (Figure 11.3.9). In particular, we are focusing on genes involved in osteoclast formation (Figure 11.3.10).

Pres:

Wallimann A, Thompson K, Stanic B, Akdis C, O'Mahony L, Moriarty F. "The influence of microbial-derived metabolites on bone health" at SBMS Summer School 16-17 May 2019 Bern and at MIM retreat 29-31 August, Grindelwald, Switzerland. (Oral)

Wallimann A, Thompson K, Stanic B, Akdis C, O'Mahony L, Moriarty F. "The influence of microbial-derived metabolites on bone health" at WIRM 3-6 April 2019 Davos, Switzerland, eCM conference 26-28 June 2019 Davos, Switzerland, SSM Annual Meeting 3-4 September 2019 Zurich, Switzerland and EAACI Winter School 23-26 January 2020, Chamonix, France.

Wallimann A, Thompson K, Stanic B, Akdis C, O'Mahony L, Moriarty F. Poster award for an outstanding poster presentation at EAACI Winter School 23-26 January 2020, Chamonix, France.

Partner:

- Liam O'Mahony, University College Cork, Ireland

Development of 3 dimensional in vitro models of bone infection (Immunobact) (M Stoddart, S Zeiter, F Moriarty)

Staphylococcus aureus is a prominent pathogen in bone-related infections where it can form staphylococcal abscess communities (SACs). SACs are a dense population of *S. aureus* within a fibrin pseudocapsule and are implicated in fracture related infection.

The goal of this project is to establish an in vitro SAC model that resembles in vivo SACs.

In vivo: (Figure 11.3.11 A+B) in vivo SACs have been characterized in mice infected with *S. aureus* and which had a femoral double osteotomy. Around the SAC (Figure 11.3.11 A, asterisk) there are cells that cannot reach the bacteria and are entrapped within an encapsulation (Figure 11.3.11 A, arrow heads). This encapsulation consisted of fibrin (Figure 11.3.11 B, violet) and contained alpha-smooth muscle actin (α SMA)- and F4/80-positive cells (Figure 11.3.11 B, yellow and green, respectively).

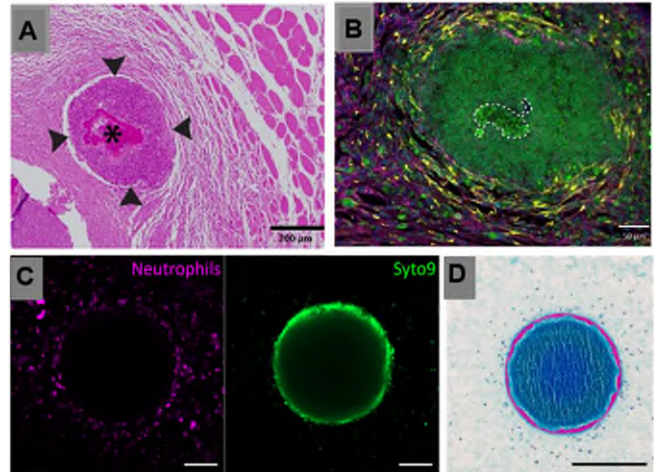

In vitro: (Figure 11.3.12 C+D) an in vitro SAC model has been established that resembles in vivo SACs; they have a fibrin pseudocapsule and they are not affected by neutrophils nor antibiotics.

Pres:

Hofstee M, Riool M, Thompson K, Zaat SAJ, Stoddart MJ, Richards RG, Moriarty TJ. "A novel 3-dimensional in vitro model for *Staphylococcus aureus* abscess communities", Maastricht, the Netherlands, 2-4 October 2019 (oral)

Hofstee M, Riool M, Thompson K, Zaat SAJ, Stoddart MJ, Richards RG, Moriarty TF. "A novel 3-dimensional in vitro model for *Staphylococcus aureus* abscess communities", Davos, Switzerland, 26-28 June 2019 (poster)

Hofstee M, Riool M, Thompson K, Zaat SAJ, Stoddart MJ, Richards RG, Moriarty TF. "A novel 3-dimensional multicellular *in vitro* model for *Staphylococcus aureus* microcolony interaction with neutrophils.", Davos, Switzerland, 6-9 April 2019 (poster)

Partner:

- SAJ Zaat (MD), Amsterdam UMC location AMC

A humanized mouse model for investigating *Staphylococcus aureus* implant-associated infections (HuMouse) (S Zeiter, F Moriarty)

Background: *Staphylococcus aureus*, continues to be the leading cause of implant-associated osteomyelitis, including fracture related infections (FRI) and peri-prosthetic joint infection (PJI). To date, no vaccine for this important pathogen exists. As the unique specificity of *S. aureus* as a human pathogen becomes better understood, it seems that reliance on murine models to produce pre-clinical data presents many shortcomings and may have contributed to previous failures in vaccine development.

Goal: Develop a humanized mouse model of osteomyelitis.

Results: Immunodeficient non-obese diabetic (NOD)–*scid* IL2R γ null (NSG) mice are engrafted with human hematopoietic stem cells (HSC), and subjected to *S. aureus* transtibial implant-associated osteomyelitis. Interestingly, we observed that humanized mice have: 1) increased weight loss, staphylococcal abscess colonies (SACs), and extensive osteolysis during MRSA infection, 2) increased *S. aureus* dissemination to distant organs, 3) more severe *S. aureus* bacteraemia resulting from osteomyelitis when human T-cell numbers are low. This study

presents significant step towards an appropriate animal model for studying a human-specific pathogen such as *S. aureus*.

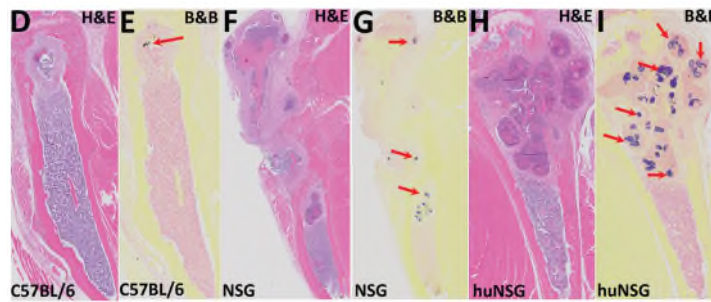

Figure 11.3.13: Humanized mice exhibit increased disease severity to *S. aureus* osteomyelitis induced sepsis. (D, F, H) demonstrates extensive osteolysis revealed by bone histology in huNSG. Brown & Brenn (B&B) staining (E, G, I) reveals numerous staphylococcal abscesses (SACs) formed in huNSG mice (red arrows). In sharp contrast, NSG and C57BL/6 WT mice exhibited fewer SACs and less osteolysis.

Partners:

- Muthukrishnan G (PhD), University of Rochester, USA
- Schwarz E (Prof), University of Rochester, USA
- Daiss J (PhD), University of Rochester, USA

Bone defect healing after chronically infected non-union (Mascot) (D Eglin, F Moriarty, S Zeiter)

Background: One of the few treatment modalities for large bone defects after treatment of fracture related infection is the induced membrane technique (IMT), however, prior to developing new interventions that treat infection and support bone healing, a suitable animal model is required.

Goal: To develop a rabbit humerus defect model that includes IMT and bone grafting due to infection.

Results: Text The first step was to transform our well-established model of humeral osteotomy in rabbits into a 5 mm defect model. The defect was filled with a PMMA spacer (Figure 11.3.14) to induce a membrane. After three weeks, the PMMA spacer was removed and exchanged for either a bone void filler (Tricalciumphosphate) or the defect was left empty. In total 11 rabbits were operated successfully suggesting the model is functional and early results (Figure 11.3.14) suggest bone healing is ongoing in the defect-filled group. Outlook: in 2020 it is planned to further characterize the induced membrane in this rabbit model and afterwards to introduce a local infection.

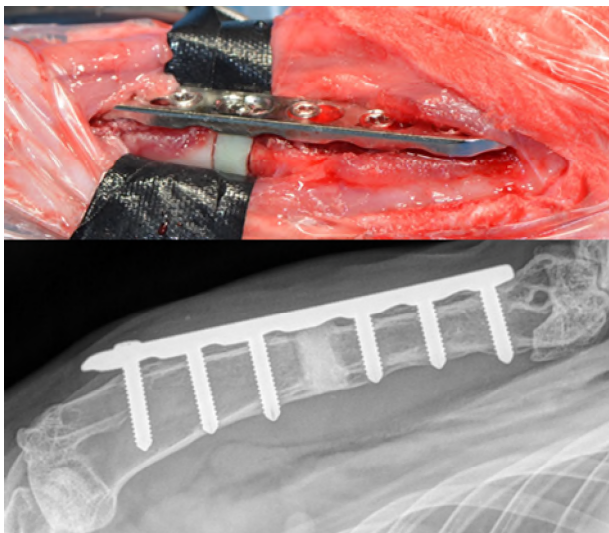

Figure 11.3.14: Upper image shows intraoperative situation after placement of the PMMA spacer into the defect. Lower image shows signs of healing 7 weeks after revision and placement of a TCP bone void filler.

Partners:

- Mario Morgenstern (MD), University Hospital Basel, Switzerland
- Willem-Jan Metsemakers (Prof), University Hospitals Leuven, Belgium

Feasibility study to evaluate the specific micro-RNA profile resulting from fracture-related infection (Xtra-Bac) (M Stoddart, S Zeiter, F Moriarty)

Background: Fracture-related infection can be difficult to identify and diagnose at its early stages. However, bone repair has been shown to correlate with the release of extracellular vesicles harboring specific micro-RNAs (miRNAs), which function to modulate gene expression at the post-transcriptional level. The sequence specificity of miRNAs can signal a specific immune response, a signal which could be utilized as an early indicator of infection. Goal: To identify infection specific miRNA signals in patients with confirmed infection and experimentally infected mice.

Results: An infected murine osteotomy repair model was devised, and mice were infected with a clinical strain of *Staphylococcus aureus*. Serum samples were taken from infected and non-infected mice and will be compared to serum samples from infected and non-infected fracture patients by performing total RNA sequencing with the intention of identifying microRNAs consistently associated with infection.



Figure 11.3.15: A 4-hole Mouse-Fix plate (7 x 1.5 x 0.7 mm) on an osteotomised mouse femur that has been infected with *S. aureus*. A minor debridement is performed 5 days post infection shown here. Serum samples are collected for miRNA analysis.

MRSA infection in a large animal model: direct re-nailing with local antibiotics in a hydrogel (MRSingle) (W Boot, S. Zeiter, D Eglin, F Moriarty)

Background: Both one and two stage revision of fracture related infection (FRI) have a high reinfection rate, especially for infections caused by bacteria resistant to antibiotics. We have previously shown that a vancomycin and gentamicin-containing hydrogel (THH) was shown to treat MRSA-infected sheep in a two-stage exchange of an IM nail.

Goal: The goal of this study was to determine if the locally applied antibiotic may be effective in a one-stage procedure when compared with current gold standard, antibiotic loaded bone cement.

Results: All sheep that completed treatment were cured of deep implant related osteomyelitis as demonstrated in the Figure below (11.3.16). Two sheep receiving the THH and one sheep receiving PMMA had low levels of MRSA isolated in the soft tissue and/or bone at the inoculation site, indicative of superficial infection.

Figure 11.3.16: Left: Schematic image of THH (blue) applied around an IM nail in the sheep model. Right: Quantitative bacteriological evaluation showing successful clearance of the infection from the IM canal and from the implant.

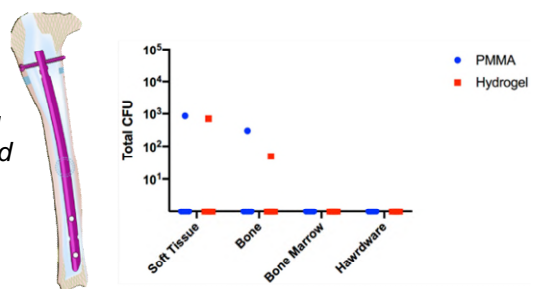

Investigating the impact of analgesic drugs on the risk and treatment of fracture related infection (PanTher) (B Stanic, K Thompson, S Zeiter, F Moriarty)

Background: The management of pain in trauma patients is a necessary and key part of patient care. The medications used in controlling pain may also have an anti-inflammatory effect, which is generally considered beneficial for the patient in the control of pain or post-fracture swelling. Some such medications are considered risk factors for non-union and may also compromise host antibacterial defences.

Goal: Determine if pain management medications have an influence on Fracture related infection (FRI) in rats.

Results: NSAID treatment dramatically affects the efficacy of a combination antibiotic treatment that reliably clears the infection in healthy animals (Figure 11.3.17). Dexamethasone, on the other hand, does not impact upon treatment of FRI. Further investigations are ongoing to evaluate bone related changes by CT between groups, and additional test groups medicated with an opioid.

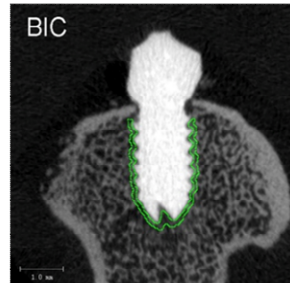
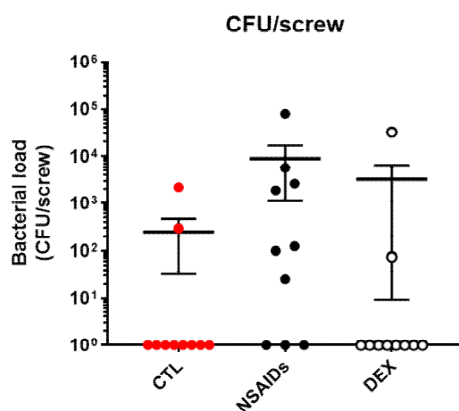
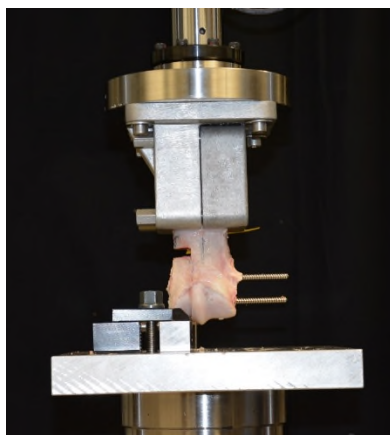

Figure 11.3.17: Quantitative bacteriological evaluation of rats treated with antibiotics for an *S. epidermidis* infection in a rat screw model as shown on right. The control (CTL) and dexamethasone (Dex) treated animals generally clear the infection, however, NSAID treatment compromises treatment success.

11.4 AOVET

Biomechanical effects of different cortex screw head sizes in equine medial condylar fracture fixation (HeadsUP) (C Constant, I Zderic, D Arens, B Pugliese, D Gehweiler, B Gueorguiev, S Zeiter)

Background: The currently available 5.5 mm cortex screw with 8 mm head size, used for large animal fracture fixation, is with ratio of 1.45 between them, being outside of the EN ISO standard range (1.75 – 2.00) required for human orthopedic cortical screws.



Goal: To compare the biomechanical competency of a new modified 5.5 mm cortex screw with 10 mm head size versus the regular 5.5 mm one in equine medial condylar fracture fixation. Results: Following creation of complete parasagittal lateral osteotomies in fifteen pairs of equine cadaveric third metacarpal bones, assigned pairwise for fixation with either the modified or the regular cortical screw, maximal insertion torque and load to failure under axial loading were evaluated for each specimen. The modified 5.5 mm cortex screw with larger head of 10 mm size achieved higher insertion torque, was less susceptible to stripping, and seemed to resist higher load to failure compared to the regular 5.5 mm cortex screw with 8 mm head size.

Figure 11.4.1: Setup with an equine specimen mounted for biomechanical testing.

11.5 AOTC System

AO Fracture Monitor – Clinical data collection on external fixator patients (SmartFix II) (Ongoing) (M Ernst, M Windolf)

Background: The AO Fracture Monitor is a system developed for continuous in-vivo monitoring of fracture healing (Project 'AO Fracture Monitor') in order to overcome the shortcomings of radiographic methods and instead deliver a reliable, quantitative and timely feedback on healing progression. While the system already delivered preclinical proof of concept, further evidence on its performance and usability in a clinical setting is needed.

Goal: AO Fracture Monitor prototypes will be implemented in 10 patients with externally fixated tibia fractures until removal of the fixation hardware at BGU Tübingen, Germany. Healing parameters generated by the device shall reflect the course of healing as observed from clinical and radiological evaluation and thereby strengthen the evidence of the system in a challenging clinical setting.

Results: Clinical data collection is almost completed, with only one patient still left active in the project. Average follow-up time prior to implant removal was 150 days. The external fixator had to be replaced with an intramedullary nail in 3 patients. The monitors provided uninterrupted data flows, with a few exceptions of unintentional device reset, where a manual restart was needed. Despite being hard to determine the loading conditions arising from a hexapod fixator used, the fracture monitor was still able to resolve changes in fracture stiffness throughout the course of healing in most of the cases. Many of the project findings are taken into account for design purposes during the current development of an implantable fracture monitor system.

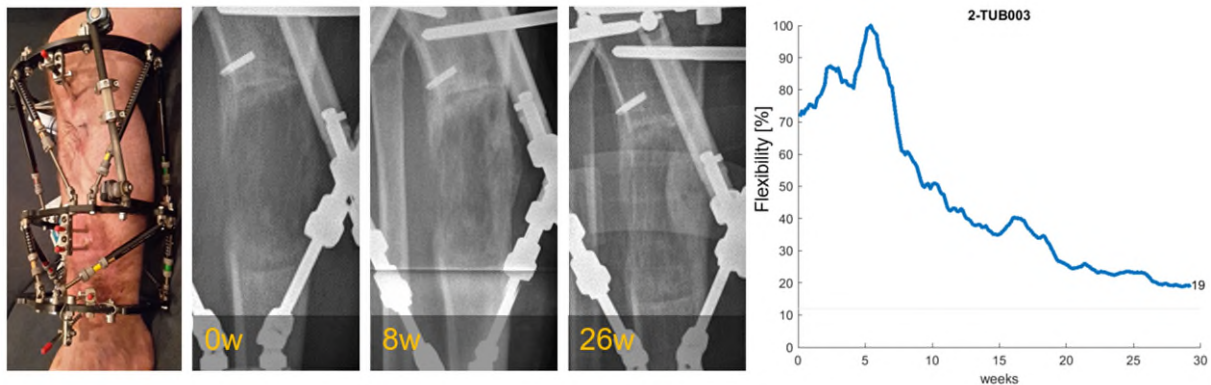

Figure 11.5.1: Photo (left) and X-Rays (middle) of the AO Fracture Monitor being implemented in a hexapod external fixator, together with its processed data (right).

Partners:

- Baumgartner H (MD), BG Unfallklinik Tübingen, Germany
- Döbele S (MD), BG Unfallklinik Tübingen, Germany
- Höntzsch D (Prof), BG Unfallklinik Tübingen, Germany
- Pohlemann T (Prof), University Clinic Saarland, Homburg, Germany

Biomechanical evaluation of femoral neck fracture fixation with the Femoral Neck System in comparison to the Hansson Pin system (FNSHansson) (I Zderic, C Schopper, B Gueorguiev)

Background: Femoral neck fractures account for half of all hip fractures and are recognized as a major public health problem associated with a high socioeconomic burden. The recently introduced implant Femoral Neck System (FNS) was developed for dynamic fixation of femoral neck fractures and provides angular stability in combination with a minimally invasive surgical technique. Alternatively, the Hansson Pin System (HPS) with two parallel pins exploits the advantages of internal buttressing. However, the obligate peripheral placement of the pins renders the instrumentation more challenging. So far, it has remained unclear which fixation system provides higher biomechanical stability.

Goal: To evaluate the biomechanical performance of FNS versus HPS in a Pauwels II femoral neck fracture model with simulated posterior comminution.

Results: Forty-degree Pauwels II femoral neck fractures (AO 31-B2.1) with 15° posterior wedge osteotomy were simulated in 14 paired fresh-frozen human cadaveric femora, followed by instrumentation with either FNS or HPS in pair-matched fashion. Implant positioning was quantified by measuring the shortest distances between implant and both inferior (DI) and posterior (DP) cortex on anteroposterior and axial X-rays. Biomechanical testing was performed in 20° adduction and 10° flexion of the specimens in a novel setup with simulated iliopsoas muscle tension. Progressively increasing cyclic loading was applied until construct failure. Interfragmentary femoral head-to-shaft movements, namely varus deformation, dorsal tilting and rotation around the neck axis were measured by means of motion tracking and compared between the two fixation groups. In addition, varus deformation and dorsal tilting were correlated with DI and DP. From a biomechanical perspective, by providing superior resistance against varus deformation and being less sensitive to variations in implant placement, the angular stable Femoral Neck System can be considered as a valid alternative to the Hansson Pin System for the treatment of Pauwels II femoral neck fractures.

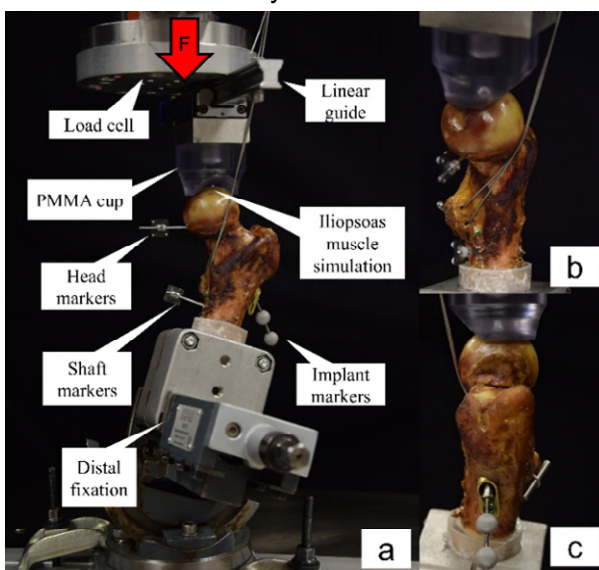

Figure 11.5.2: Setup with a specimen mounted for biomechanical testing; a) anterior view with vertical arrow denoting loading direction; b) medial and c) lateral view depicting simulation of the iliopsoas muscle.

Pres:

Schopper C, Zderic I, Menze J, Müller D, Rocci M, Knobe M, Shoda E, Richards RG, Gueorguiev B. Better stability and more predictive fixation of the Femoral Neck System versus two Hansson Pins in Pauwels II femoral neck fractures – a biomechanical study. 2019 EORS (oral)

Partners:

- Stoffel K (Prof), University Hospital Basel, Basel, Switzerland
- Sommer C (MD), Cantonal Hospital Graubünden, Chur, Switzerland
- Müller D, Menze J, DePuy Synthes, Zuchwil, Switzerland

Biomechanical investigation of intrathoracic versus extrathoracic rib fracture plating (RibPlate) (ongoing) (D Mischler, C Schopper, B Gueorguiev)

Background: The high morbidity following surgical interventions on the chest wall due to large incisions, especially when treating subscapular fractures, often prevents surgeons from operative rib fracture fixation. Minimally invasive approaches to the intrathoracic side of the rib could allow for smaller incisions with lower morbidity, while maintaining construct stability.

Goal: To compare (1) the biomechanical competence of intrathoracic versus extrathoracic plating of rib fractures and (2) the biomechanical performance of 2 versus 3 screws per fracture fragment.

Results: Forty paired ribs were fractured under 3-point bending and randomized to 4 fixation groups instrumented with either intra- or extrathoracic plate position using 2 or 3 screws per fracture fragment. They were cyclically tested over 400'000 cycles under a combined torsional and tensile bending loading by load application ranging from 2 to 5 N. Stiffness and subsidence of the construct were calculated from the cyclic data. Subsequently, load to failure under ramped compression bending loading was evaluated. Compared to the native state, intrathoracic plating provided a significant increase in construct stiffness versus the extrathoracic plating, thus indicating superior fixation stability of the intrathoracic approach. The use of only 2 instead of 3 screws per fragment for plating was found to maintain the stability of fixation. In a clinical context, fewer screws could decrease surgery costs, reduce surgery duration and allow for smaller incisions with lower morbidity.

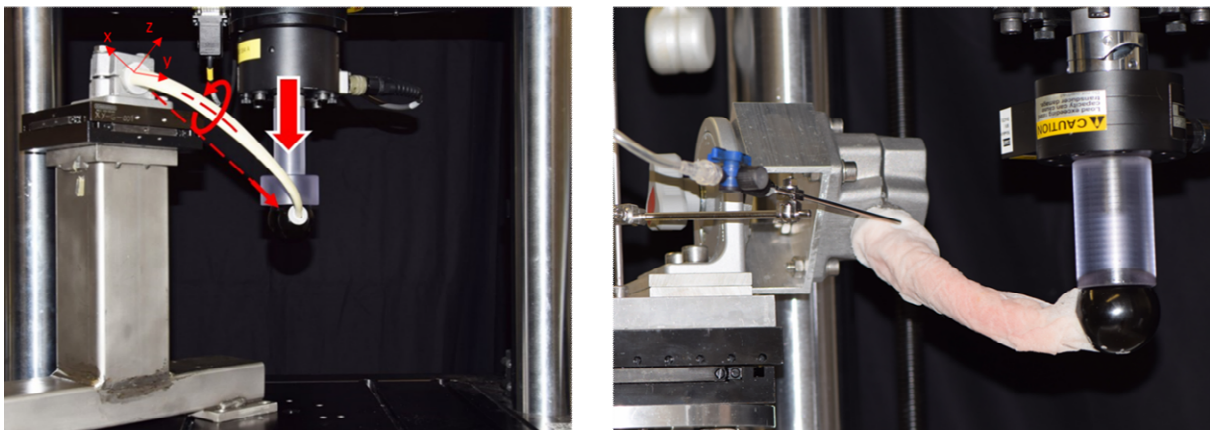

Figure 11.5.3: Two views of the setup with a specimen mounted for biomechanical testing under combined torsional and tensile bending loading.

Partners:

- Gasparri M (Prof), Medical College of Wisconsin, USA
- Schulz-Drost S (MD), University Hospital Erlangen, Germany
- Brace M, DePuy Synthes, USA

Testing of two different implant concepts for growth plate modulation in sheep (Nitinvivo) (D Gehweiler, D Nehrbass, N Goudsouzian, B Gueorguiev)

Background: Leg length discrepancy (LLD) in children is a relevant problem in today's orthopedic surgery. If left untreated, LLD can lead to serious damage in adulthood. The standard treatment is the use of Eight Plates in the longer leg bridging the growth plate to slow down bone growth. However, this plate is not approved for LLD corrections and complications such as screw deformations or breakage can occur. In addition, it is difficult to determine the correct time for implant removal, not least because overshooting growth (rebound effect) may occur after removal.

Goal: To compare a new implant prototype to the existing Eight Plate in their ability to slow down bone growth in a sheep model.

Results: Sheep metatarsal bones were operated with the 2 implant types for LLD correction, followed by implants removal 24 weeks post operation, growth monitoring for another 12 weeks, and histological analysis. The application of the new implant prototype seems to be advantageous over the Eight Plate, with no clearly observed rebound effect after its removal.

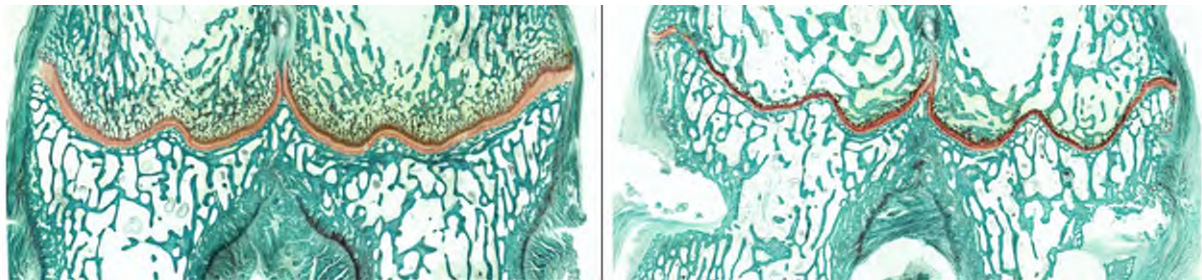

Figure 11.5.4: Safranin O/Fast Green histological staining of sheep distal metatarsal bone with visualized growth plate; left: untreated leg; right: leg treated with the new implant prototype for LLD correction.

Partners:

- Dwyer J (MD), University Hospital of North Staffordshire, Stoke-on-Trent, UK
- Slongo T (MD), University Children's, Hospital, Berne, Switzerland
- Narayanan U (Prof), University of Toronto, Toronto, Canada
- Mukhopadhaya J (MD), Paras Hospital, Patna, India
- Sepulveda M (MD), Universidad Austral de Chile, Valdivia, Chile

BacterioPHAGE therapy for fracture-related infection due to *Staphylococcus aureus* (PhageS) (S Zeiter, F Moriarty)

Background: Fracture-related infections generally involve biofilm formation and are therefore always highly antibiotic tolerant, even in the absence of specific antibiotic resistance genes. Goal: This project aims to determine the *in vivo* efficacy of a phage-loaded thermo-responsive hyaluronan gel as a local application mode for bacteriophage therapy of difficult to treat, antibiotic resistant orthopaedic device-associated infections.

Results: In a rabbit humerus osteotomy and LCP fixation model with *S. aureus* inoculation, the phage-loaded hydrogel was pipetted onto the LCP. After surgery, the animals were observed for one week after which they were euthanized. In the soft tissue, there was a significant decrease in bacterial load in the animals that received the phage-loaded hydrogel (Figure 11.5.5).

Figure 11.5.5: Quantitative bacteriological evaluation of soft tissue of a group of rabbits receiving a phage-loaded hydrogel as a prophylaxis against infection.

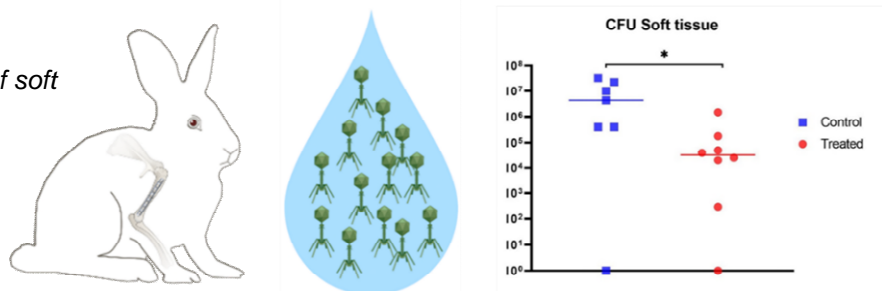

Pres:

Onsea J. AOTCPP (AOTrauma Clinical priority program Bone Infection, Vienna, Austria). 21. September 2019. " BacterioPHAGE therapy for fracture-related infection due to *S. aureus*" (oral)

Partners:

- Metsemakers WJ (MD) KU Leuven, Belgium
- Lavigne R (MD), KU Leuven, Belgium
- Trampuz A (MD), Charité, Berlin, Germany

11.6 ARI Exploratory Research

Xin1 functional extensions for photo-based X-Ray transmission and real-time feedback (Xin1-Go) (Ongoing) (J Buschbaum, M Windolf)

Background: Achieving correct anatomical alignment plays a key role in many surgical interventions in traumatology and orthopedics, such as fracture reduction or corrective osteotomies. Missing both intraoperative feedback and monitoring capabilities of the anatomical relations complicate the surgeries and often result in poor outcomes in terms of skeletal malalignments. Current solutions for computer aided surgery could be helpful, however, lack of wider acceptance due to considerable disadvantages in terms of complexity, costs and effectiveness.

Goal: To develop a simple surgical measurement tool for intraoperative real-time feedback in order to improve precision and clinical outcome.

Results: A system prototype was realized, which includes functionalities to control correction osteotomies and reduction of femoral fractures. The system is based on previous tracking technology invented in ARI and requires only a mobile device with optical camera (eg., smartphone) and 2 plastic reference markers. By placing the reference markers at specific anatomical regions, spatial relation of the latter can be determined and tracked. A software processes the video stream from the in-built camera, continuously calculating the position of the references and thus the anatomical relations. The actual values are displayed in real-time on the screen, so that the surgeon can easily monitor and act accordingly. The prototype has demonstrated its functionality in bench-mark tests showing that the system can deliver relevant information for intraoperative benefits to facilitate and improve surgical interventions.



Figure 11.6.1: Prototype of the surgical measurement device to control reduction of femoral fractures.

Development of long-term skin attachable activity tracker for research purposes (ActiveTrack) (V Varjas, M Windolf)

Background: The potential of individualized rehabilitation to improve patient outcomes is undisputed but still only barely touched. Sensor devices, such as activity trackers utilizing latest technologies may deliver valuable data for patient specific post-treatment care. The focus of the latter is currently shifting towards preventive actions outside the care institute. Analysis of post-treatment activity data could lead to new patient outcome measures, as patient activity features might indicate the physical and mental state of the patient.

Goal: In order to analyze activity patterns during recovery from skeletal injuries, a wireless, long-term wearable device is required, capable of recording raw triaxial physiological acceleration data at minimal to no user interaction with no need of removing it from its initial position and without causing discomfort to the patient. The aim of the project was to develop and evaluate the feasibility of a prototype activity tracker for research purposes that can be used in (pre-)clinical studies in order to improve patient outcomes.

Results: During the concept development phase, 2 major hurdles became apparent: (1) targeted technologies in combination with long lifetime- and small size requirements would currently inhibit a leap innovation in comparison to already available solutions; (2) despite some early phase developments, no reliable non-irritating long-term skin attachment technology was found available on the market. Due to these key obstacles the project was put on hold until new opportunities appear on the horizon.

Partner:

- Grimm B (Prof), The Human Motion Institute, Munich, Germany

Creation of a statistical form model of the cortical femur with tools for automatic feature extraction and fracturing (cortFemSFM) (Ongoing) (H Noser, L Kamer)

Background: Bone models are required in many projects on preclinical research and development, however, the traditional approach for their acquisition is expensive and time consuming.

In some cases, computerized bone models can be used as alternative approach. For example, the analysis of individual anatomy or variation patterns of a given population sample can facilitate surgical decision making, preoperative planning and development of implants for orthopedic trauma care.

Goal: To develop a workflow and generate a 3D statistical form model of the femur and its cortex, containing inherent anatomical information about the femoral size, cortical thickness, shape and length.

Results: New modules under development include 3D modeling of the femoral cortex and fracture pattern, including fracture segments and a module for morphometric analysis (e.g., for length and angle measurements). Currently, 40 CT scans of the femur have been segmented, and a workflow has been developed to produce a 3D statistical form model of the femur and its cortex. The procedure includes a fracture tool that requires outlining the fracture lines to generate fracture segments thereof.

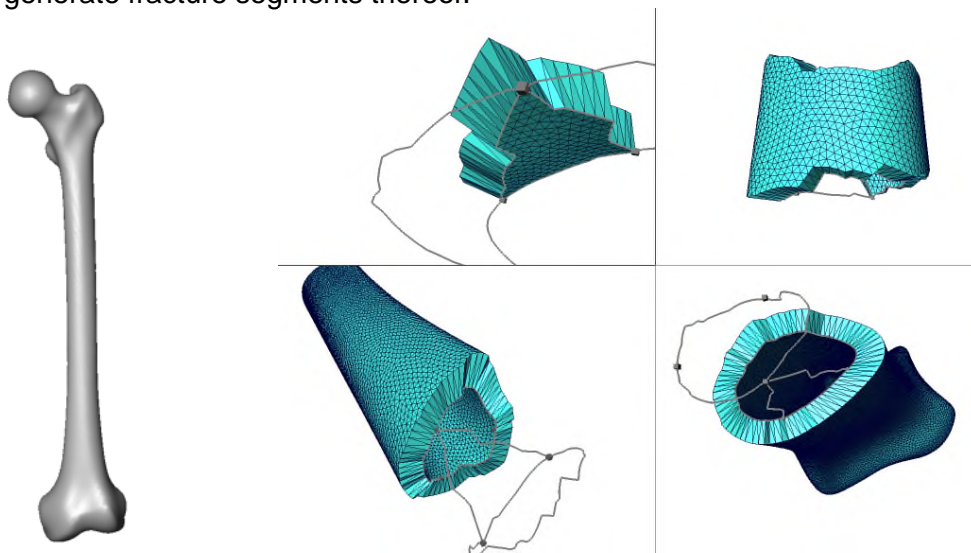

Figure 11.6.2: Computation of the mean outer surface model of the femur (left) and an example of fracture segments extraction of a cortical model (right).

Coronoid process replacement with individually designed 3D printed prosthesis (Y Pukalski, J Barcik, I Zderic, B Gueorguiev)

Background: Coronoid fractures account for 2 to 15% of the cases with elbow dislocations and usually occur as part of complex injuries. Comminuted fractures and non-unions necessitate coronoid fixation, reconstruction or replacement.

Goal: To develop an individually designed 3D printed coronoid prosthesis with curved cemented intramedullary stem and compare its stability to both radial head grafted reconstruction and coronoid fixation with 2 screws.

Results: Based on CT scans of cadaveric forearms, 6 individualized coronoid prostheses with curved cemented intramedullary stems were designed and 3D printed from stainless steel. Eighteen human cadaveric proximal ulnas were osteotomized at 40% of the coronoid height and assigned to 3 groups treated with either (1) an individualized coronoid prosthesis with curved cemented intramedullary stem, (2) an ipsilateral radial head autograft fixed with two anteroposterior screws, or (3) two anteroposterior screws fixing the osteotomized coronoid. All specimens were biomechanically tested under ramped quasi-static axial loading to failure.

Prosthetic treatment resulted in significantly higher stiffness and failure load compared to both radial head autograft reconstruction and coronoid screw fixation, showing that in cases of coronoid deficiency, replacement of the coronoid process with an anatomically shaped individually designed 3D printed prosthesis with a curved cemented intramedullary stem seems to be an effective method restoring the buttress coronoid function under axial loading. In the clinical practice, implementation of this prosthesis type could allow for early patient mobilization with better short- and long-term treatment outcomes and may be beneficial for patients with irreparable comminuted coronoid fractures, severe arthritic changes or non-unions.

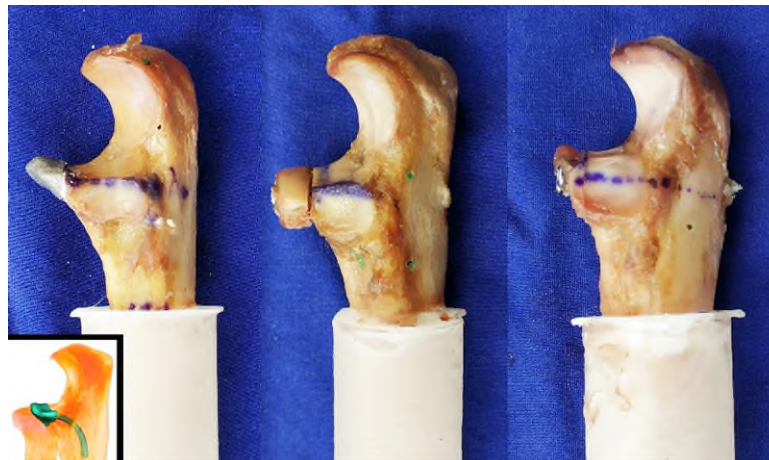

Figure 11.6.3: Photographs of proximal ulnar specimens as prepared for biomechanical testing by means of prosthetic treatment (left), radial head autograft reconstruction (middle), and coronoid screw fixation (right), being embedded distally in PMMA.

Partners:

- Enchev D (Prof), University Multiprofile Hospital for Active Treatment and Emergency Medicine 'NI Pirogov', Sofia, Bulgaria
- Baltov A (Prof), University Multiprofile Hospital for Active Treatment and Emergency Medicine 'NI Pirogov', Sofia, Bulgaria
- Rashkov (Prof), University Multiprofile Hospital for Active Treatment and Emergency Medicine 'NI Pirogov', Sofia, Bulgaria

Biomechanical evaluation different fixation methods for three types of pelvic ring fractures (M Lodde, I Zderic, B Gueorguiev)

Background: Pelvic ring fractures occur with an incidence of 0.3 to 8% and have a bimodal distribution affecting young and active or elderly fragile patients. Different classification systems have been developed for a better understanding of a specific pelvic ring fracture, eg., fractures of fragile bone without an adequate injury mechanism are classified using the Fragility Fractures of the Pelvis (FFP) classification system. There are several minimal invasive stabilization techniques and strategies available, but the biomechanical efficiency of these fixations for various fracture types has not yet been fully understood.

Goal: To examine biomechanically different fixation methods for (1) AO C1-3/FFP IIIc unstable pelvic fractures, (2) AO 61 B3.3/Young-Burgess LC III bilateral superior and inferior pubic ramus (Butterfly) fractures, and (3) AO 61 C1.3/FFP IIb non-displaced sacral crush fractures in artificial pelvic bone models.

Results: Cyclic loading to failure was performed on instrumented artificial bone models using either a hemi-pelvic one-leg-stance or a two-leg stance model to evaluate and compare the biomechanical competence of various fixation techniques. Interfragmentary motions were continuously measured throughout the test cycles by means of optical motion tracking. The results of three sub-studies highlighted the best fixations strategies for the different fracture types, as follows. First, in FFP IIIc fractures using an SI screw together with anterior plate or creeping screw provided the highest stability. If an FFP IIIc fracture is present, both the anterior and posterior pelvic ring should be addressed. Stabilization of the anterior pelvic ring by means of an external fixator significantly improved the stability compared to an isolated stabilization of the posterior pelvic ring. An S1-S2-Ala-iliac construction was particularly well suited for stabilizing the posterior pelvic ring fracture. Second, for surgical treatment of Butterfly fractures, there was no significant difference between anterior plate osteosynthesis and trans-pubic bilateral screw osteosynthesis regarding axial stiffness, cycles and maximum force to failure and dislocation after 500 cycles. Depending on the clinical picture, either open surgical plate osteosynthesis or the rather minimally invasive use of trans-pubic screws can be used. Third, the use of a Herbert Screw for fixation of the posterior pelvic ring in AO 61 C1.3 fractures was compared to one SI screw, two parallel SI screws or one augmented SI screw. Cement augmentation of the SI screw resulted in significantly more stability. The use of two SI screws, augmented SI screw and the Herbert Screw seemed to be biomechanically superior to the conventional SI screw.

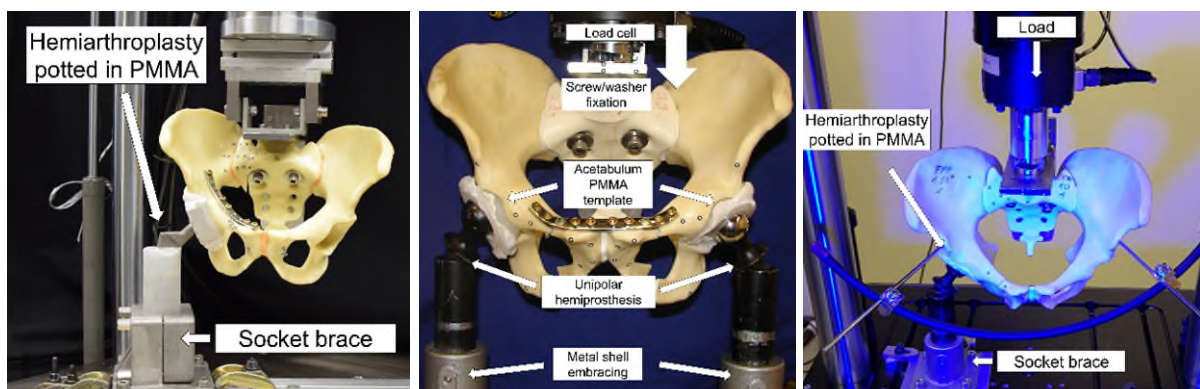

Figure 11.6.4: Setups with specimens mounted for biomechanical testing, used for evaluation of different fixation methods in FFP IIIc fractures (left), butterfly fractures (middle), and AO 61 C1.3 fractures (right).

Partner:

- Raschke M (Prof), Münster University Hospital, Münster, Germany

Biomechanical investigation of locked plating and interlocked nailing of comminuted calcaneal fractures (A Stefanov, S Ivanov, B Gueorguiev)

Background: Treatment of comminuted calcaneal fractures remains controversial and challenging. Anatomic reduction with stable fixation results in better outcomes than nonoperative treatment of displaced intraarticular fractures involving the posterior facet and the anterior calcaneocuboid joint (CCJ) articulating surface.

Goal: To investigate the biomechanical performance of 3 different methods for fixation of comminuted calcaneal fractures.

Results: Comminuted calcaneal fractures, including Sanders III AB fracture of the posterior facet and Kinner II B fracture of the CCJ articulating surface, were simulated in 18 human cadaveric lower legs, randomized to 3 groups for fixation with either (1) 2.7 mm variable-angle (VA) locking anterolateral calcaneal plate in combination with 2 cannulated screws, (2) 2.7 mm VA locking lateral calcaneal plate, or (3) interlocking calcaneal nail with 3 separate cannulated screws, and biomechanically tested until failure under progressively increasing cyclic loading in simulated midstance position.

Plating with the larger lateral plate demonstrated the highest susceptibility to varus deformation and was associated with the biggest decrease in the Böhler angle, whereas both fixations with the smaller anterolateral plate and nail evidenced higher stability. Treatment of comminuted calcaneal fractures using either locked plate with additional longitudinal screws or interlocked nail combined with separate transversal screws seems to provide superior stability as opposed to plating only.

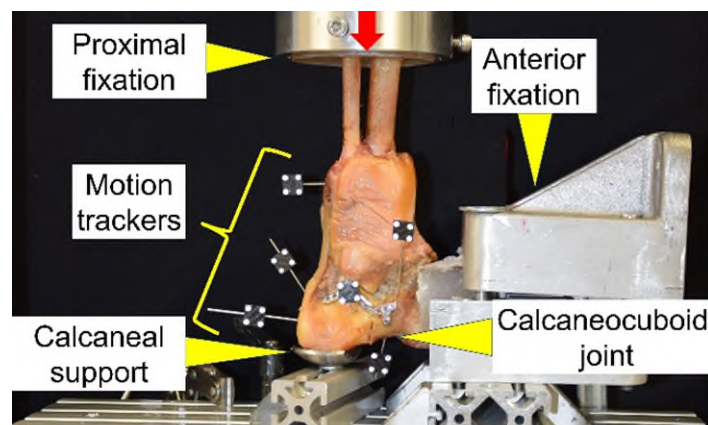

Figure 11.6.5: Setup with a specimen mounted for biomechanical testing.

Partners:

- Enchev D (Prof), University Multiprofile Hospital for Active Treatment and Emergency Medicine 'NI Pirogov', Sofia, Bulgaria
- Baltov A (Prof), University Multiprofile Hospital for Active Treatment and Emergency Medicine 'NI Pirogov', Sofia, Bulgaria
- Raykov D (Prof), Medical University Varna, Varna, Bulgaria
- Rashkov (Prof), University Multiprofile Hospital for Active Treatment and Emergency Medicine 'NI Pirogov', Sofia, Bulgaria

Analysis of three different screw configurations for fixation of Sanders Type II B intraarticular calcaneal fractures (S Ivanov, A Stefanov, B Gueorguiev)

Background: Intraarticular calcaneal fractures are devastating injuries with significant socioeconomic impact due to prolonged recovery periods. In recent years, less invasive screw fixation techniques have been increasingly applied to improve functional outcomes and reduce wound complications. Appropriate screw configuration is mandatory for good fixation stability to allow for early exercise and fast recovery. However, the effect of screw configuration on the biomechanical competence of the fixation construct has remained unknown.

Goal: To assess the biomechanical performance of three different screw configurations for fixation of Sanders type II B calcaneal fractures.

Results: Intraarticular Sanders type II B calcaneus fractures were simulated in 15 human cadaveric feet by means of osteotomies. The specimens were randomized into 3 groups for fixation with either (1) two 6.5 mm parallel longitudinal screws entering the tuber calcanei above the insertion of the Achilles tendon to the anterior process, (2) two 6.5 mm parallel screws entering the tuber below the Achilles tendon aiming at the anterior process, or (3) two 6.5 mm parallel longitudinal screws entering the tuber calcanei above the Achilles tendon engaging the anterior process. Bone mineral density was equalized among the groups. Each specimen was biomechanically tested under cyclic axial loading with the hindfoot in a simulated midstance position. The initial peak load of 200 N was progressively increased by 0.1 N/cycle. Interfragmentary movements were captured by means of optical motion tracking. From biomechanical point of view, calcaneal screw configuration implementing one oblique screw, buttressing the posterior facet, seems to provide the highest hindfoot stability under dynamic loading. Support of the posterior facet by means of buttress or proximally inserted longitudinal screws was associated with lower vertical subsidence and significantly less plantar movements compared to a screw configuration with more distally placed longitudinal screws.

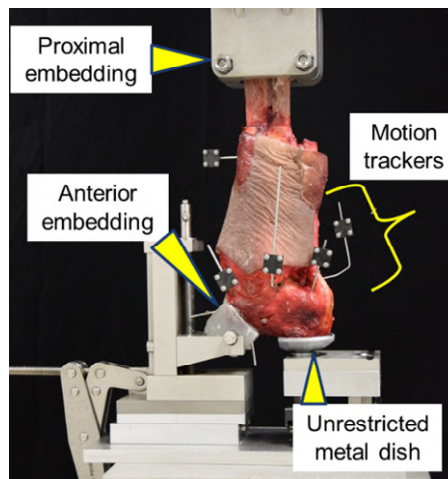

Figure 11.6.6: Test setup with a specimen mounted for mechanical testing.

Partner:

- Raykov D (Prof), Medical University Varna, Varna, Bulgaria

Investigation of the added value of 3D segmented CT images to the classification accuracy of proximal humeral fractures (FractSeg) (Ongoing) (J Dauwe, K Mys, J Schader, B Gueorguiev, P Varga)

Background: Osteosynthesis of proximal humeral fractures remains challenging with a high failure rate reported in the literature. This might be due to the complexity of these injuries, the difficulties in the appropriate selection and correct execution of treatment. Understanding and correct classification of the fracture are important for preoperative planning. Nevertheless, this is a challenging task in case of complex fractures, partially due to difficulties in recognizing their 3D extent, including the number and dislocation of fragments. Preoperative CT is a standard procedure in most hospitals, but the contained information may not be fully utilized. Advanced visualization of the CT images may improve the accuracy of fracture classification.

Goal: To investigate the feasibility and added value of semi-automatic segmented 3D CT visualizations in proximal humeral fracture classification for observers with two different experience levels: residents and specialized shoulder surgeons.

Results: Seventeen patients with proximal humeral fractures and a preoperative CT scan were included in this retrospective study. The CT scans were semi-automatically segmented,

indicating every fracture fragment in a different color. Fracture classification ability of 21 orthopedic residents and 12 experienced shoulder surgeons was tested. Both groups were asked to classify the fractures using 3 different modalities (standard slice-wise CT analysis, conventional 3D CT reconstruction, and 3D segmented model) into three different classification systems (Neer, AO and LEGO). All participants were able to classify the fractures significantly better using the 3D segmentations (94% correct answers on average) compared with the conventional 3D reconstructions (54%) and with the standard slice-wise CT analysis (35%) into the three classification systems, $p < 0.01$. Both observer groups achieved significantly worse classification accuracy in the LEGO system compared to the two others.

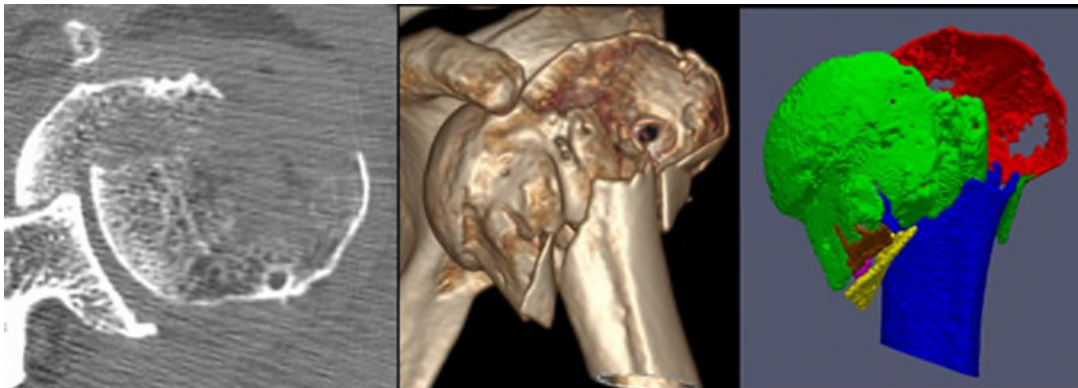

Figure 11.6.7: Illustration of the 3 modalities used for fracture classification exemplified on a head split proximal humeral fracture: standard slice-wise CT scan (left, axial view), conventional 3D reconstruction (middle), and 3D segmented model with colored fragments (right).

Partners:

- Putzeys G (MD), AZ Groeninge Hospital Kortrijk, Belgium
- Nijs S (Prof), University Hospitals Leuven, Belgium

Virtual plate fixation of long bone fractures for educational purposes (OSApp) (P Varga, D Mischler, S Perren, M Windolf)

Background: Failure of internal fixations is to a large extent due to incorrect surgical techniques and basic technical errors. The rate of fixation failures could be reduced by appropriate pre-operative planning and adhering to the principles of fracture fixation. These principles are usually well taught and learnt, but an in-depth understanding of the underlying biomechanical relationships is often missing. Better biomechanical understanding is expected to help surgeons interpret correctly the fracture situation, develop a successful fixation strategy and avoid pitfalls. Textbook-based (passive) learning may be ineffective, while hands-on (active learning) courses are limited in availability and scope. A virtual learning platform could be utilized as a complementary approach to fill this experiential gap.

Goal: To develop the pilot version of an interactive software tool to demonstrate the biomechanical principles of plate fixations of long bone fractures and to foster the understanding of surgeons.

Results: A functional prototype of the virtual osteosynthesis software tool has been developed. The prototype offers in an interactive and intuitive virtual environment where the user can freely configure the plate fixation in abstracted but relevant fracture situations. The adjustable variables include selection of the fracture type, size and location of the plate, types and positions of the screws, and mode and magnitude of loading. The main outcomes focus on within-implant stresses and interfragmentary motions and deformations, allowing the user to recognise and reduce the risk of implant failure, and to optimize theoretically the mechanical stimuli for bone healing, respectively. The results corresponding to the selected fixation configuration become immediately available from the underlying finite element simulation

database. Besides fostering self-driven learning and understanding of the basic principles such as plate working length, the tool includes a tutorial-based directed learning platform. Here, virtual replicates of clinical fixation cases that mechanically failed or led to non-healing are utilized to explain the biomechanical conceptual mistakes that led to the given failure. The tool was showcased during the AO Courses 2019 and received very positive feedback.

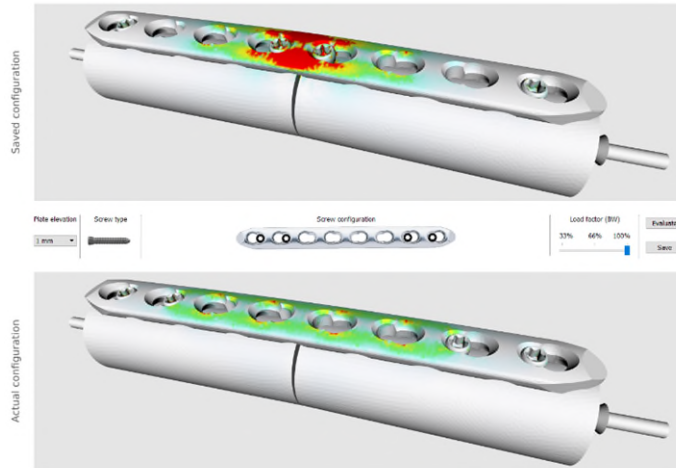

Figure 11.6.8: Snapshot of the virtual plate fixation module illustrating the biomechanical outcomes of two fixation configurations utilizing different plate working lengths.

Partner:

- Lambert S (MD), University College London Hospital, UK

Biomechanical comparison of two implant head elements for screw-blade anchorage in the femoral head (K Keck, C Schopper, I Zderic, J Schader, G Sanchez, B Gueorguiev)

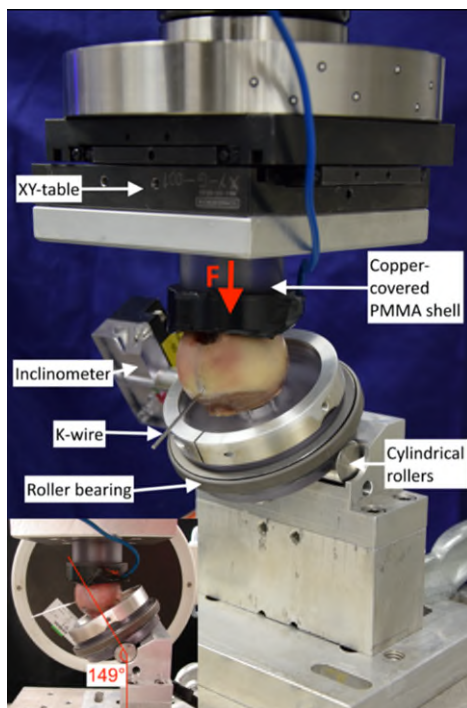

Figure 11.6.9: Setup with a specimen mounted for biomechanical testing.

Background: Proximal femoral fractures are the most common fractures in patients older than 65 years, being accompanied by high complication rates ranging up to 35% for femoral neck fractures and up to 15% for trochanteric ones. Despite the variety of existing implant systems, their treatment is still challenging. The screw-blade implant systems, being a combination of a lag screw and a blade adding rotation stability to the femoral head, offer a new approach for improvement of the osseous purchase, especially in osteoporotic bone.

Goal: To compare biomechanically the head element (HE) anchorage of 2 screw-blade implant systems in the femoral head.

Results: Twenty paired human cadaveric femoral heads were assigned to 4 groups (n=10), implanted with either Rotationally Stable Screw-Anchor (RoSA) HE or Gamma3 Rotation Control Lag Screw (U-Blade) in center or off-center position, and biomechanically tested under progressively increasing cyclic axial loading at 2 Hz. U-Blade revealed better femoral head anchorage in center position compared to RoSA HE. On the other hand, RoSA HE seems to react less sensitive to suboptimal screw insertion in off-center position than U-Blade.

Partner:

- Knoke M (Prof), Cantonal Hospital Lucerne, Switzerland

Analgesic efficacy of ultrasound-guided block of sciatic and femoral nerves in experimental sheep (V Stenger, S Zeiter)

Background: Current anaesthesia protocol at the ARI for orthopaedic hindlimb surgery in sheep includes epidural anaesthesia. Possible complications with an epidural analgesia are urine retention, neural damage, neuritis and temporarily loss of motor function in both hindlimbs. Nevertheless, it is very important to use local analgesia in order to save on anaesthetics and thus reduce their side effects. Therefore, in this study we investigated another protocol for local analgesia: the peripheral nerve block. To provide local analgesia in the operated hind limb we performed an ultrasound-guided block of the sciatic and femoral nerve and compared the analgesic efficacy of the nerve blocks with the epidural analgesia.

Goal: Refinement of the current analgesia and anaesthesia protocol used in the ARI for sheep undergoing invasive surgery on one hind limb.

Results: Ultrasound-guided peripheral nerve block is a reliable technique in sheep. There was no difference in analgesic effect of epidural and peripheral nerve block. A benefit of the peripheral nerve block is the earlier return to mobility in the recovery period since only the operated leg is motorically restricted.



Figure 11.6.10: Ultrasonographic image of the left femoral nerve, femoral artery and vein (a), needle (b) and femur (c).

Partner:

- Rohrbach H (Dr med vet), VetSuisse University of Bern, Switzerland

Investigation of the pharmacokinetics of fentanyl patches at different locations on sheep (Fentasheep) (Ongoing) (T Buchholz, S Zeiter)

Background: The sheep is a frequently used animal model for orthopedic research at the ARI mostly involving invasive surgery on the hind limb. Therefore, the sheep need general anesthesia. These painful procedures can only be ethically justified with the application of an adequate analgesia protocol. A transdermal fentanyl patch is a great way of application to administer fentanyl over a longer period avoiding stressful injections for the animal.

The uptake of fentanyl through the skin depends on various factors (fat content of the skin, temperature, blood circulation). A comparison of different locations is needed to clarify the best and most feasible skin area to apply a transdermal fentanyl patch. With an identification of the characteristics of the uptake of fentanyl in sheep, the current analgesia protocol could be adapted in order to be more reliable.

Goal: In accordance with the refinement of the 3R principle, the aim of this study was to improve the analgesia protocols used at the ARI for sheep undergoing orthopedic surgery.

Results: ongoing

Partners:

- Spadavecchia C (Prof) VetSuisse University of Bern, Switzerland
- Rohrbach H (Dr med vet), VetSuisse University of Bern, Switzerland
- Heider A, Swiss Institute of Allergy and Asthma (SIAF), Davos, Switzerland

Enhancing cartilage self-repair using cell-free IPN biopolymer hydrogels. GELHOME 2 (Ongoing) (M D'Este, D Eglin)

Acute cartilage defects are a significant source of suffering and disability, leading to productivity loss and significant healthcare costs. Aging population and increase in physical activity at all ages are amplifying the societal impact of cartilage defects, which in the long-term contribute to osteoarthritis onset. Materials trying to match cartilage resilience are usually unsuitable for cell invasion, new tissue formation and adhesion to native tissue, which is the first requirement for lateral integration.

Double-network hydrogels are specialized interpenetrating polymeric networks with outstanding strength and toughness. Double networks were initially developed from non-biodegradable materials unsuitable for long-term implantation. Recent advances have demonstrated how the same design paradigm can be employed to fabricate biopolymer-based tough double network hydrogels (Figure 11.6.11).

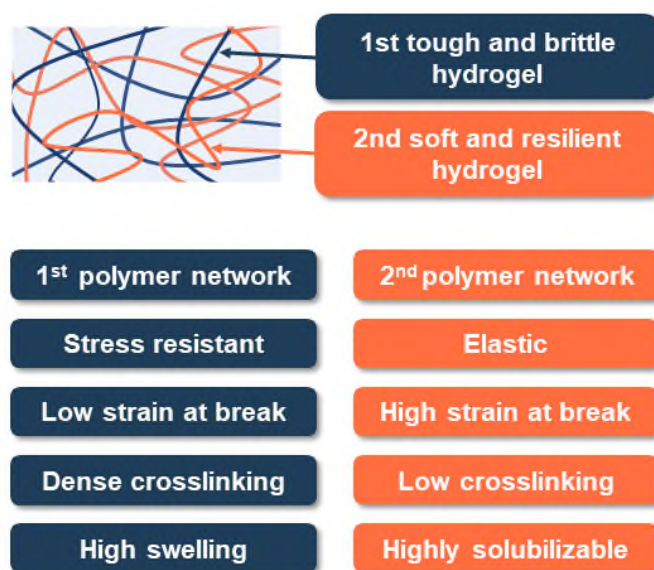

Figure 11.6.11: In this project, we are engineering combinations of biopolymers for obtaining hydrogels with i) high resilience; ii) high strength to withstand repeated mechanical load; iii) adhesion to cartilage under physiological conditions; iv) cytocompatibility and capability of being invaded by cells from underlying bone marrow and/or adjacent cartilage; v) patentability and overall design prone to clinical translation and development into a product.

Pres:

Eglin D. Fabrication of stimuli responsive hydrogel microenvironments for cell manipulation TERMIS EU, Rhodos, 2019, p. 605 / 66 (eCM coll).

D'Este M. From bench science to clinical translation: patents in biomaterials., ESB European Society for Biomaterials ESBioMat, Dresden, 2019.

D'Este M. Towards Clinical Translation: Patents and Intellectual Property in Biomaterials Science. Stem Cell Biology & Technology Royan International Twin Congress. Reproductive Biomedicine & Stem Cells, Tehran. Teheran, 2019.

Pub:

Tognato R, Armiento AR, Bonfrate V, Levato R, Malda J, Alini M, Eglin D, Giancane G, Serra T. A Stimuli-Responsive Nanocomposite for 3D Anisotropic Cell-Guidance and Magnetic Soft Robotics, *Adv Funct Mater* 29(9) (2019) 10.

Safari F, Fani N, Eglin D, Alini M, Stoddart MJ, Eslaminejad MB. Human Umbilical Cord-derived Scaffolds for Cartilage Tissue Engineering, *J Biomed Mater Res A* 107(8) (2019) 1793-1802.

Partner:

- Ferguson S (Prof), ETH Zurich, Zurich, Switzerland

Dorsal root ganglion response to intervertebral disc degenerative environment (NEURODISC2) (J Ma, S Grad, M Peroglio, M Alini)

Background: Low back and neck pain have been repeatedly reported as leading causes of disability worldwide. Back pain can have many different origins and is therefore difficult to treat, especially in the case of chronic back pain. Intervertebral disc (IVD) degeneration is one of the major causes, with a correlation between degeneration and pain. It has been demonstrated that disc degeneration impacts the adjacent nervous system structures, such as the nerve roots or the dorsal root ganglion (DRG). Consequently, DRG may become more sensitive to nociceptive stimuli and spontaneous activation resulting in a nonfunctional response. Moreover, IVD degeneration can also lead to neural plasticity and an ingrowth of nerve fibers into deeper layers of the anulus fibrosus. A better understanding the link between IVD degeneration and pathological change in the sensory nervous system may help to develop novel therapies against back pain.

Goal: The project aimed to study how the degenerative IVD influences dorsal root ganglion (DRG) and spinal cord glia using in vitro and ex-vivo models in order to better understand the link between IVD degeneration and pain.

Results: DRG primary cell and DRG organ cultures were established from various species. We found that stress factors commonly observed in degenerative IVD, like hypoxia and low glucose, contribute to aberrant neurite sprouting. This was consistently observed in the DRG cell line ND7/23, DRG primary cells and explant culture models. Moreover, hypoxia and acidosis induced a higher spontaneous and bradykinin-stimulated calcium response compared to normoxia and neutral pH cultures, suggesting that these factors could be implicated in the development of spontaneous and inflammatory pain.

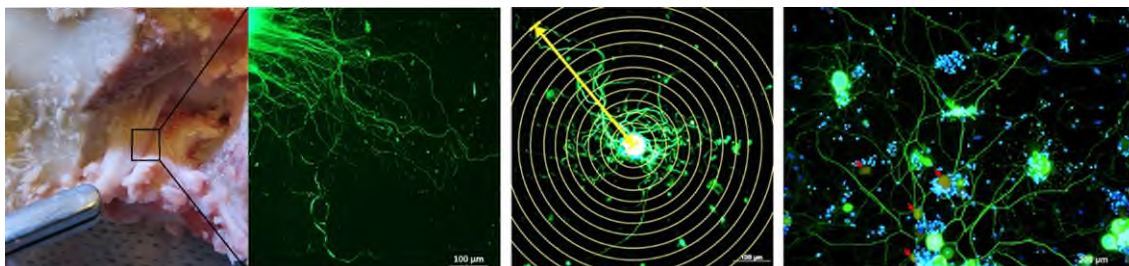

Figure 11.6.12: (left) dissection of a dorsal root ganglion (DRG) in sheep and neurite outgrowth following 5 days of culture, (middle) quantification of outgrowth length from a DRG, (right) assessment of viability of DRG primary cells (blue: cell nuclei, green: live cells, red: dead cells).

Pres:

Ma J, Stefanoska D, Grad S, Alini M, Peroglio M. Hypoxia and low pH stressed disc conditioned medium promotes hypersensitivity of peripheral sensory neurons. ORS PSRS 5th Symposium, Skytop PA (US), Nov 3-7, 2019 (poster).

Stefanoska D, Ma J, Grad S, Alini M, Peroglio M. Effects of glucose concentration and pH on dorsal root ganglion neurite outgrowth. Pain in EU XI EFIC, Valencia (Spain), Sep 4-7, 2019 (e-poster).

Ma J, Stefanoska D, Grad S, Alini M, Peroglio M. Effect of pH and oxygen tension on dorsal root ganglion calcium response to bradykinin and neurite sprouting. Pain in EU XI EFIC, Valencia (Spain), Sept 4-7, 2019 (poster).

Ma J, Stefanoska D, Hildebrand M, Zeiter S, Alini M, Peroglio M. Validation of cell line models to study intervertebral disc neo-innervation associated with discogenic pain. Swiss 3R Day, Bern (CH), Sept 2, 2019 (poster).

Ma J, Stefanoska D, Grad S, Alini M, Peroglio M. Low pH culture of dorsal root ganglion cells as an in vitro model to study pathological changes involved in the development of neuropathic pain. 7th International Congress on Neuropathic Pain, London (UK), May 9-11, 2019 (poster).

Ma J, Stefanoska D, Grad S, Alini M, Peroglio M. Hypoxic stress enhances extension and branching of sensory neuronal outgrowth: a comparison between in vitro and ex vivo model. 7th International Congress on Neuropathic Pain, London (UK), May 9-11, 2019 (poster).

Partners:

- Häckel S (MD), Orthopaedics Department, Inselspital, University of Bern, Switzerland
- Pandit A (Prof), Centre for Research in Medical Devices (CÚRAM), National University of Ireland, Galway

Cell homing in the degenerative intervertebral disc: Characterization of migrating cells and their regenerative potential (DISCREGEN2) (S Grad, M Peroglio, Z Li, M Alini)

Background: Homing of human mesenchymal stem cells (MSCs) has been described as potential alternative to MSC injection, aiming to enhance the regenerative capacity of the intervertebral disc (IVD). However, the effect of MSC homing on the IVD cells is not well known yet.

Goal: To investigate the effect of MSC homing on the IVD progenitor cell population, the IVD cell survival and their proliferative response.

Results: Human MSCs were isolated from vertebral bone marrow aspirates, labeled and seeded onto the endplate of bovine IVDs and human IVD tissue. Following MSC migration for 5 days, IVD cells were isolated by tissue digestion. The fractions of IVD progenitor cells, dead, apoptotic, and proliferative IVD cells were evaluated by flow cytometry and compared to untreated IVDs. For human IVDs, three groups were investigated: non-degenerated (organ donors), IVDs of patients suffering from spinal trauma, and degenerative IVD tissue samples. MSC homing enhanced the fraction of IVD progenitor cells in bovine and human IVD samples. Furthermore, a significant proliferative response and lower fraction of dead cells were observed after MSC homing in both bovine and human IVD tissues. Our findings indicated that MSC homing enhanced the survival and regenerative capability of IVD cells, which may be mediated by intercellular communication. MSC homing could represent a potential treatment strategy to prevent the onset of the degenerative cascade in IVDs at risk such as IVDs adjacent to a fused segment or IVDs after herniation.

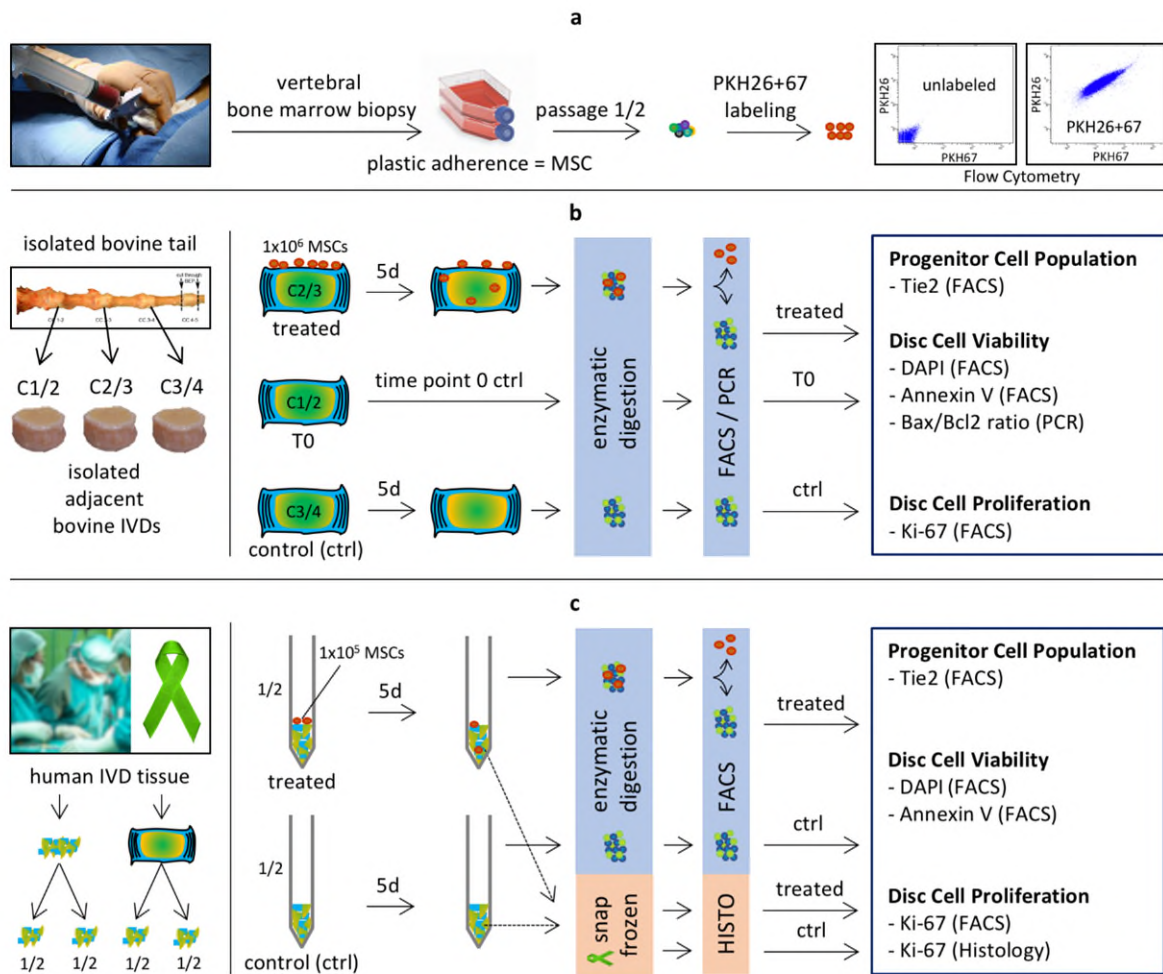

Figure 11.6.13. a) Isolation of MSCs from vertebral bone marrow aspirate by plastic adherence. MSCs were labeled and labeling was confirmed by flow cytometry. **b)** IVDs with endplates were isolated from bovine tails. Adjacent IVDs were randomly assigned to: time point zero ctrl (T0), day 5 untreated control (ctrl) and day 5 treated disc by MSC homing (treated). **c)** Human IVD tissue was isolated during surgery or from organ donors. Tissue from one donor was divided in halves. One half was treated by MSC homing (treated), the second half was used as untreated control (ctrl).

Pres:

Wangler S, Peroglio M, Menzel U, Benneker LM, Haglund L, Sakai D, Alini M, Grad S. MSC homing facilitates IVD cell survival, proliferation and enhances the Tie2 positive IVD progenitor cell subpopulation, BioSpine 2019, Rom, IT (podium)

Wangler S, Peroglio M, Li Z, Menzel U, Benneker LM, Richards RG, Alini M, Grad S. Homing of Mesenchymal Stem Cells into Degenerated Intervertebral Discs - An Alternative to Stem Cell Injection? Global Spine Congress 2019, Toronto, CA (poster)

Wangler S, Peroglio M, Menzel U, Benneker LM, Haglund L, Sakai D, Alini M, Grad S. MSC homing into intervertebral discs enhances the Tie2 positive progenitor cell population, prevents cell death and induces a proliferative response. ISSLS Conference 2019, Kyoto, JP (special poster)

Pub:

Wangler S, Menzel U, Li Z, Ma J, Hoppe S, Benneker LM, Alini M, Grad S, Peroglio M. CD146/MCAM distinguishes stem cell subpopulations with distinct migration and regenerative potential in degenerative intervertebral discs. *Osteoarthritis Cartilage* 27(7):1094-1105, 2019.

Wangler S, Peroglio M, Menzel U, Benneker LM, Haglund L, Sakai D, Alini M, Grad S. Mesenchymal stem cell homing into intervertebral discs enhances the Tie2 positive progenitor cell population, prevents cell death and induces a proliferative response. *Spine (Phila Pa 1976)* 44(23):1613-1622, 2019.

Partners:

- Benneker L (Prof), Inselspital Bern, Switzerland
- Sakai D (Prof), Tokai University School of Medicine, Japan
- Haglund L (Prof), Montreal General Hospital, Montreal, Canada

Neopeptide peptides as biomarkers of early intervertebral disc degeneration (NeoDisc) (Z Li, M Alini, S Grad, M Peroglio)

Background: To date there is an unmet need for reliable, predictive, cost effective diagnostic and prognostic tools for spinal disorders related to intervertebral disc (IVD) herniation or degeneration. Investigation into early molecular changes using a reproducible ex vivo model for disc degeneration, will identify tissue failure at the cellular and extracellular matrix level before structural changes occur.

Goal: Aggrecan and collagen cleavage occur in IVD aging and degeneration. This project aims to evaluate the appearance of these neopeptide peptides in IVD degeneration induced by detrimental mechanical loading, which may be utilized as early diagnostic biomarkers for disc herniation.

Results: Degeneration in bovine caudal IVDs was induced with one strike loading at 50% of the disc height followed by 0 (short term) or 7 days (long term) of culture under physiological loading. The IVDs were fixed with formalin, embedded in paraffin, and sectioned with a microtome. The existence of MMP cleaved C-terminus (MMPCC) aggrecan neopeptide was revealed with immunohistochemistry staining. The one strike loading long term group showed a stronger MMPCC aggrecan neopeptide staining intensity in the NP area compared with the day 0 healthy control, physiological group, and one strike short term group (Figure 11.6.14).

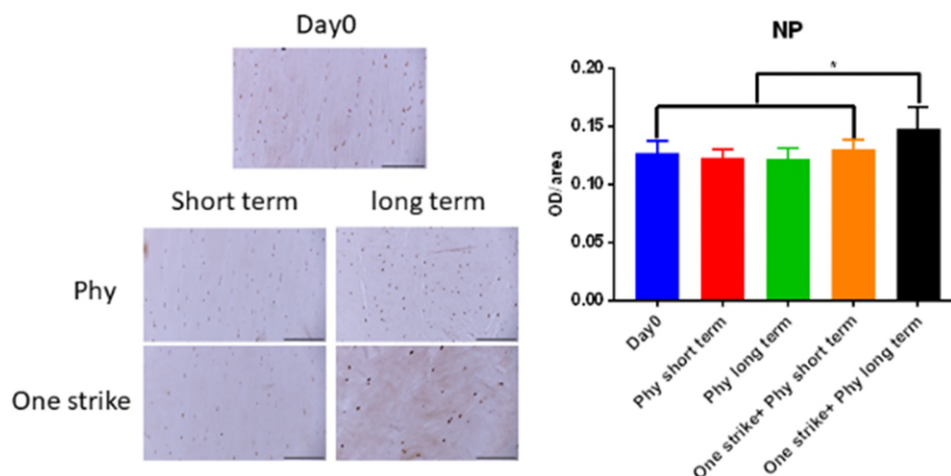

Figure 11.6.14: Aggrecan neopeptide IHC staining with MMPCC antibody. Bovine caudal IVDs collected at day 0, cultured under physiological loading (Phy) for 1 day (short term) or 8 days (long term), or one strike loading followed by physiological loading for 0 (short term) or 7 days (long term). Quantification of the optical density (OD)/area value. Mean±SEM, n=8, * p<0.05. Scale 200 µm.

Pub:

Pfannkuche J-J, Guo W, Cui S, Ma J, Lang G, Peroglio M, Richards RG, Alini M, Grad S, Li Z. Intervertebral disc organ culture for the investigation of disc pathology and regeneration – benefits, limitations, and future directions of bioreactors. *Connective Tissue Research* 2019, 26(9):1-18.

Partners:

- Neidlinger-Wilke C, University Ulm, Ulm, Germany
- Wilke HJ (Prof), University Ulm, Ulm, Germany
- Shenke-Layland K (Prof), University Tübingen, Tübingen, Germany

Development of *ex vivo* system for mesenchymal stem cell differentiation and cartilage integration (Vivoload) (Ongoing) (M Stoddart, M Alini)

Background: Current culture models to investigate cartilage repair therapies are often highly simplified. Even critical *in vivo* signals such as kinematic load are lacking. This limits the efficacy of *in vitro* tests, placing a higher burden on *in vivo* models.

Goal: This project aims to develop a novel *ex vivo* culture system, which is more representative of the *in vivo* articulating joint. Media composition, vis-à-vis synovial fluid, will be considered, as will osteochondral plug development, interaction/signaling between cartilage, bone and implant. Finally, complex multiaxial load will also be applied to produce a mechanical environment more associated with the articulating joint.

Results: Adding hyaluronic acid, either in the culture medium or mixed within the fibrin scaffold, leads to a more stable chondrogenic phenotype and an increased deposition of cartilage like matrix.

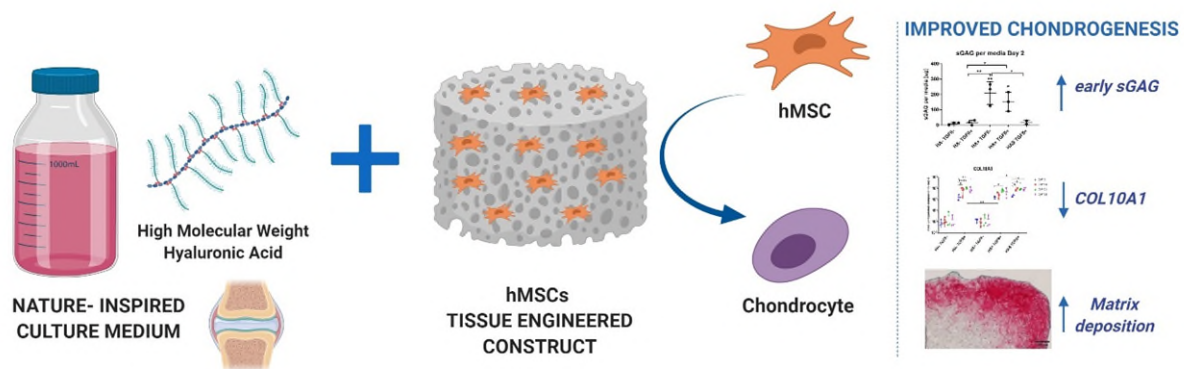

Figure 11.6.15: Improved chondrogenesis using nature inspired culture medium containing hyaluronic acid

We have also shown that the chondrogenic signal is in part generated by the mechanical induction and activation of TGF- β growth factor. This can be used as a new outcome measure to assess novel biomaterials for cartilage regeneration. We expect the incorporation of a more viscous physiological culture medium to modulate the chondrogenic induction of human mesenchymal stem cells induced by interfacial shear. New 3 layer de novo implants have been produced and subjected to complex load, allowing for the development of signaling gradients to be developed under defined conditions. Confining the implant within an osteochondral defect will also modify the response due to paracrine signaling from the viable cartilage and underlying bone. In addition, there is the potential for cell migration from the surrounding "host" tissue, which may also influence the response. Each of the conditions being modified is to bring the *in vitro* situation nearer to that found *in vivo*.

Pres:

Monaco G, Alini M, El Haj A, Stoddart MJ. Hyaluronan supplemented culture media significantly increases early chondrogenesis glycosaminoglycan synthesis and reduces the upregulation of collagen X in a stem cell-based implant. 2019 TERMIS EU (oral)

Stoddart MJ. Role of kinematic load on cell behavior. 2019 TERMIS EU (oral)

Stoddart MJ. MSCs and their potential for orthopaedic applications. The Joint Seminar Series, Rush University Medical Center, Chicago, USA. (oral)

Stoddart MJ. Role of kinematic load on cell behaviour. TERMISEU2019, Greece. (oral)

Stoddart MJ. Physical modulation to divert stem cells to chondrogenic cell fate, ORS2019, Austin, Texas, USA. (oral)

Pub:

Fahy N, Menzel U, Alini M, Stoddart MJ. Shear and Dynamic Compression Modulates the Inflammatory Phenotype of Human Monocytes in vitro. *Front Immunol.* 2019 Mar 5;10:383. doi: 10.3389/fimmu.2019.00383.

Armiento AR, Alini M, Stoddart MJ. Articular fibrocartilage - Why does hyaline cartilage fail to repair? *Adv Drug Deliv Rev.* 2019 Jun;146:289-305. doi: 10.1016/j.addr.2018.12.015

Glatt V, Evans CH, Stoddart MJ. Regenerative Rehabilitation: The role of mechanotransduction in orthopaedic regenerative medicine. *J Orthop Res.* 2019;37(6):1263-9

Partner:

- El Haj A (Prof) University of Birmingham, UK

Rational design of scaffolds for cartilage regeneration using finite element modelling (FEScaf) (M Stoddart, D Eglin, M Alini)

Background: The repair of traumatic injuries to articular cartilage is one of the major challenges in orthopedics. While there is agreement that new biomaterials to enhance repair are required, static (non-mechanically loaded) in vitro platforms lack the complex in vivo loading patterns.

Goal: A medium throughput platform that allows multiple implants to be mechanically loaded simultaneously, would allow for more representative testing of novel materials and treatments for cartilage repair.

Results: In previous studies we have shown using primary human bone marrow derived stromal cells that chondrogenesis can be induced using mechanics alone. We have also shown that redistributing cells within the scaffold can dramatically enhance matrix deposition, while the cell number is kept constant and shear is a major aspect of the response obtained. We therefore designed a 16-chamber loading device that can apply compression and interfacial shear simultaneously, mimicking joint kinematic load. This new platform offers significant opportunities for in vitro testing, following 3R principles by reducing the need for in vivo studies.

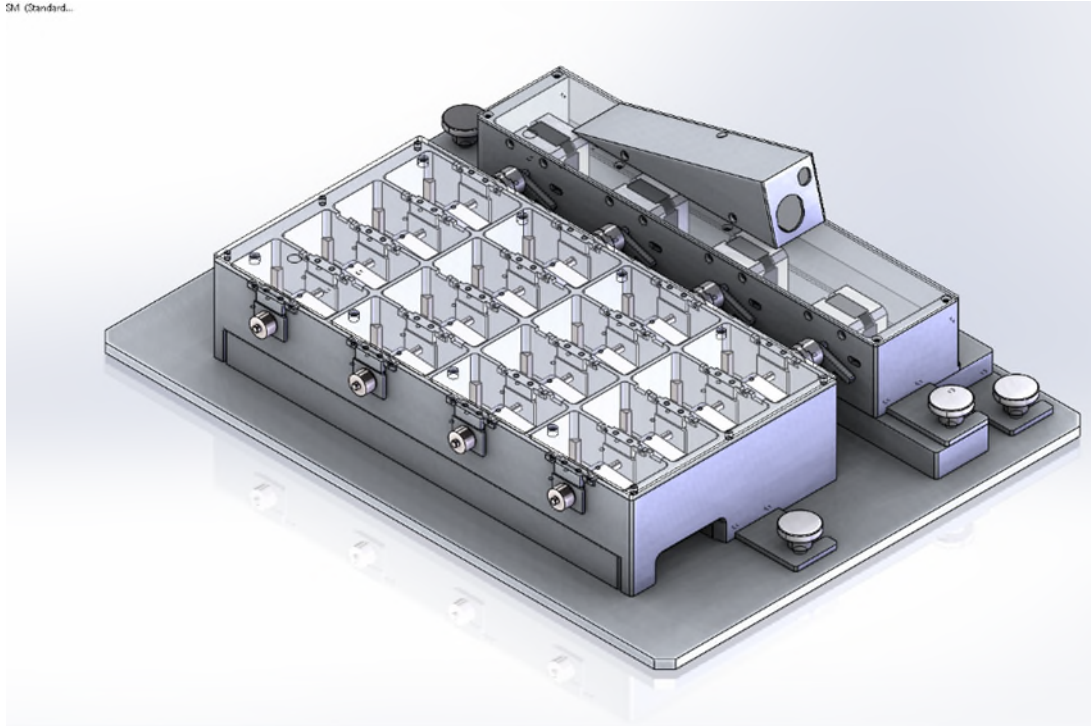

Figure 11.6.16: Schematic of the multi-axial load bioreactor.

Pub:

Johnstone B, Stoddart MJ, Im GI. Multi-disciplinary approaches for cell-based cartilage regeneration. *J Orthop Res*. 2019 Sep 3. doi: 10.1002/jor.24458.

Pres:

Stoddart MJ. The role of joint-mimicking mechanical loading in cartilage regeneration models. Erasmus+ workshop on Biomechanics, Heidelberg, Germany. (oral)

Stoddart MJ. Mechanical regulation of MSC chondrogenesis. Can we repurpose rehabilitation? Musculoskeletal Research Conference, Mayo Clinic, USA. (oral)

Local delivery of IL-1Ra as a strategy to enhance long bone healing (HealBone) (Ongoing) (K Thompson, M Stoddart, M Alini)

Background: Although 90% of fractures typically heal without complications, there remains a small proportion ($\leq 10\%$) of fractures that experience delayed healing or non-union. In patients with such healing complications, there appears to be an important contribution of an inappropriately maintained pro-inflammatory environment to the defective fracture healing process. Thus, immunomodulation of the local fracture microenvironment, such as by enhancing anti-inflammatory cytokine production, could be an effective way to enhance fracture healing in troublesome healing environments. This project focuses on investigating the therapeutic efficacy of IL-1Ra, the receptor antagonist of the potent pro-inflammatory cytokine IL-1 β .

Goal: The goals of this project include the identification and characterization of a suitable pro-inflammatory endochondral bone healing model, and to test the efficacy of IL-1Ra delivered locally to the site of injury to promote bone healing.

Results: A 2 mm femoral defect was created in skeletally mature female Fischer 344 rats, following internal plate fixation using a customized 1.25 mm-thick PEEK plate. This model of non-union has been characterized based on microCT and histological assessment, with robust bone formation but an ultimate failure to bridging up to after 14 weeks post-surgery. The creation of the defect led to elevated circulating levels of IL-1 β , which were maintained up to 10 days after surgery. Characterization of the early and local inflammatory response to the

defect demonstrated there was a time-dependent shift in the ratio between IL-1 β and IL-1Ra. Our results show that IL-1 β protein levels at the defect site persisted up to 7 days post-surgery, whilst IL-1Ra markedly increased from 10 days onwards ($p < 0.01$). Additionally, we have shown that up to 16 different inflammatory cytokines and chemokines in the bone marrow of the femur undergo significant changes in expression within 14 days post-surgery. Taken together, our findings suggest that, despite the small size of the defect, this model can be characterized by non-union in the long-term (14 weeks), and a persistent inflammatory response in the short-term (<2 weeks). With these characteristics, this model represents an excellent platform to determine the therapeutic efficacy of immunomodulatory strategies, including local delivery of IL-1Ra. On-going studies are investigating the efficacy of different biomaterials for delivery of recombinant proteins, including IL-1Ra and BMP-2, as a means of enhancing bone formation.

Pres:

Lackington WA, et al., Local administration of IL-1Ra as a strategy to enhance long bone healing. American Society for Bone and Mineral Research Annual Meeting, Orange County, Orlando, Florida, US, 2019.

Gomez MA, et al., Local non-viral gene delivery to immunomodulate and enhance fracture healing. Annual Meeting of the European Orthopaedic Research Society, Maastricht, the Netherlands, 2019.

Lackington WA, et al., Local delivery of interleukin-1 receptor antagonist (IL-1Ra) to enhance long bone healing. 10th Tissue Engineering and Regenerative Medicine International Society (TERMIS) EU Chapter Meeting, Rhodes, Greece, 2019.

Lackington WA, et al., Local delivery of interleukin-1 receptor antagonist (IL-1Ra) to enhance long bone healing. 6th Swiss Bone and Mineral Society Annual Meeting, Bern, Switzerland, 2019.

Assessing and rectifying donor variation for musculoskeletal applications (Varidon) (Ongoing) (M Stoddart, M Alini)

Background: In the development of cell-based therapies for osteochondral defects and diseases there is still considerable debate regarding which is the most suitable source of cells. A significant amount of work has been performed to investigate the suitability of bone marrow derived mesenchymal stromal cells (BMSCs). While showing promise, studies involving primary human MSCs suffer from the wide donor variation observed. For *in vitro* studies this leads to challenges involving statistical significance and the requirement for repeats from multiple donors. For clinical translation of autologous therapies, the lack of an underlying mechanism causing the variation would result in a population of poor responders being unsuitable for autologous cellular based therapies. However, the prediction of which patients are likely to respond well is currently not possible and the spread of responses obtained is loosely dismissed as donor variation. If the underlying functional mechanism for the failure to respond was determined, not only would the suitability of a particular donor for cell therapy be able to be predicted, but also a corrective measure may be realized.

Goal: Within this study we aim to identify predictive markers of human MSC chondrogenesis that can be used to stratify patient populations.

Results: We have identified a prospective chondroprogenitor marker profile that will allow for better patient stratification. Using this profile, we are also able to reverse the deficit, thus converting poor responders to more chondrogenic cells by way of a simple treatment with siRNA silencing. We are further exploring alternative strategies to manipulate cell function, using the profile as an outcome parameter. The ability to reverse this functional deficit will open new avenues for further cartilage repair therapies.

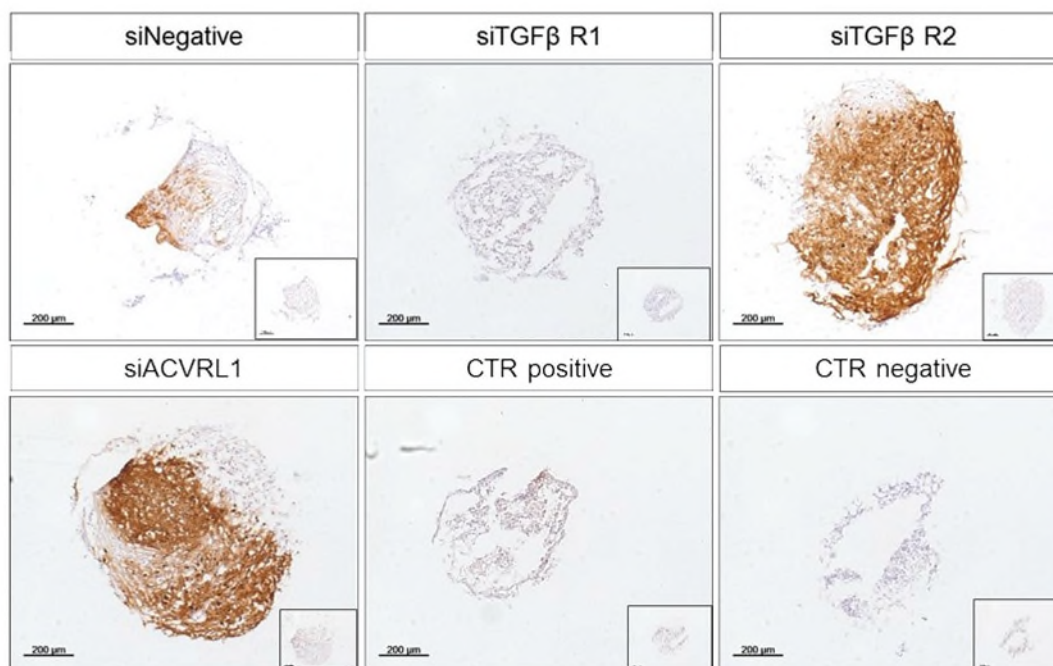

Figure 11.6.17: Non-responsive human MSC donor (bottom middle) becomes responsive after correction of the TGF β R2 expression using one dose of siRNA (Top right).

Pub:

Herrmann M, Hildebrand M, Menzel U, Fahy N, Alini M, Lang S, Benneker L, Verrier S, Stoddart MJ, Bara JJ. Phenotypic Characterization of Bone Marrow Mononuclear Cells and Derived Stromal Cell Populations from Human Iliac Crest, Vertebral Body and Femoral Head. *Int J Mol Sci.* 2019 Jul 14;20(14). pii: E3454. doi: 10.3390/ijms20143454.
 Graceffa V, Vinatier C, Guicheux J, Stoddart M, Alini M, Zeugolis DI. Chasing Chimeras – The elusive stable chondrogenic phenotype. *Biomaterials.* 2019;192:199-225

Pres:

Stoddart MJ. Stem Cells: What is the real science? ICRS 2019, Vancouver, Canada. (Plenary Speaker.)
 Basoli V, Della Bella E, Alini M, Stoddart MJ. Role of dexamethasone and (+)-ZK 216348 during chondrogenic fate in bone marrow stem cells. 2019 TERMIS EU (oral)
 Della Bella E, Basoli V, Alini M, Stoddart MJ. Dexamethasone drives early osteogenic differentiation by modulation of SOX9 and PPARG expression. 2019 TERMIS EU (oral)

Patent Submitted:

Method of determining or influencing the chondrogenic potential of mesenchymal stromal cells
 Stoddart M, Alini M

Partner:

- Johnstone B (Prof), Oregon Health & Science University, USA

Autologous 3D printed scaffolds (AutoInk) (S Verrier, D Eglin, M Alini)

The development of 3D printing and 3-dimensional assembly of multi-cellular types technologies, parallel to the increasing need of patient-specific solutions has motivated the choice of layer-by-layer bioprinting for the fabrication of complex tissue engineered cellular scaffolds or tissues. The basic material for bio-printing usually comprises a soft biomaterial (ink) loaded with living cells enabling deposition in a designed shape. Optimal features for a bioink are appropriate rheological properties, printability, cytocompatibility for cell delivery, but also mechanical stability (maintain 3D architecture) and controlled biodegradability.

Being of autologous origin, platelet rich plasma (PRP) has gained popularity in tissue repair and regeneration as potential treatment for various acute and chronic disorders in human and veterinary medicine, including tendon and craniomaxillofacial applications. PRP has proven to be an adequate extracellular matrix environment for mesenchymal stem cell proliferation and was also shown to promote vascularization when seeded with endothelial cells. Naturally rich in fibrinogen and platelets and, originally liquid PRP jellifies upon thrombin and calcium-chloride activation. The rheological properties of PRP gels are depending on its original concentration and can be modulated upon platelet activation. To date, the use of PRP in form of injectable gel or spray is widely accepted in the clinic.

The goal of this project is to develop an autologous biological ink based on platelet rich plasma for the biofabrication of shape and biologicals patient specific bone implants.

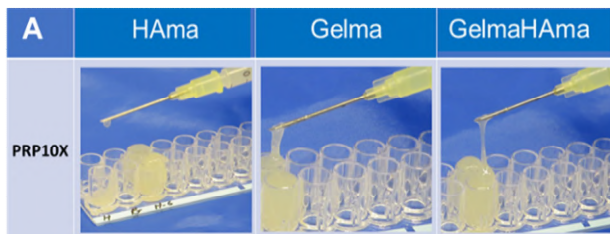
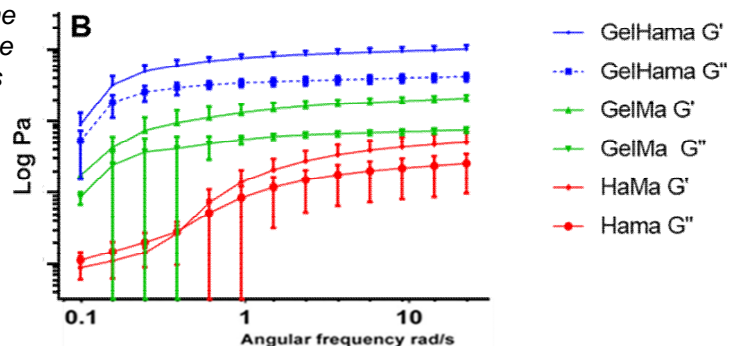

Figure 11.6.18 A: Injectability test of PRP modified by the addition of hyaluronic acid methacrylate (HaMa), gelatin methacrylate (GelMa), or a mix of both (GelHama).

Figure 11.6.18 B: Rheological analysis of the above mentioned PRP composites. Storage modulus (G') and loss modulus (G'') as function of angular frequency shows the efficiency of cross-linking if the gels.



Pres:

Healing of large bone defects. S, Verrier, 4th congress Gene Therapy & Regenerative Medicine, Athens, Greece, May 2019. (invited presentation)

Regulation of pericyte function in angiogenesis and tissue regeneration: The role for T-cadherin.

Dasen B, Guerrero J, Scherberich A, Verrier S, Martin I, Philippova M.

2019 TERMIS EU (oral)

Pub:

Herrmann M, Stanic B, Hildebrand M, Alini M, Verrier S. In Vitro Simulation of the Early Proinflammatory Phase in Fracture Healing Reveals Strong Immunomodulatory Effects of CD146-positive Mesenchymal Stromal Cells. *J Tissue Eng Regen Med.* 2019;13(8):1466-1481

11.7 OCD Consortium

Osteochondral defects are still a major clinical challenge. They represent a large societal burden as they limit employment and impede daily life activities of millions of Europeans. Moreover, these injuries often lead to further degeneration of the joint, into a disabling disease known as osteoarthritis (OA). The defect bridges two major tissue types (cartilage and bone) that also have zonal structures within and specific healing capacities. Additionally, the cartilaginous surface must follow the patient specific contour of the surrounding tissue to avoid arthritic changes.

The ARI collaborative research program (CRP) OsteoChondral Defect (OCD), bring together multidisciplinary expertise in materials, bioprinting, bioreactors, biomechanics, macrophages and animal models. Additive manufacturing and Biofabrication approaches are used to produce constructs systematically evaluated to assess the influence of physical and chemical parameters on cartilage and bone repair. In addition, as the immune response and inflammatory environment is known to directly influence the repair tissue produced, the effect of the material combination on macrophage behavior is being investigated. Bioreactor and culture models that include multiple tissues of the joint completed with immune cells are used to reduce in vivo experimentation along 3R Principles. Clinical insights drive the research of the OCD to ensure that a route to translation is always a consideration. Therefore, as an underlying principle, increases in implant complexity will be justified by significant increases in implant function, thus ensuring sufficient biological benefit of additional regulatory requirements.

The project started in June 2017 and is funded for 4 years. This strong consortium is composed of five teams respectively from the University of Pennsylvania, United State, with Dr Jason Burdick, Dr Claudia Loebel and Dr Robert Mauck; The University Medical Center Utrecht, the Netherlands, with Florencia Abinzano, Dr Riccardo Levato and Prof Jos Malda; The University Medical Center Rotterdam, the Netherlands, with Tim Wesdorp, Dr Yvonne Bastiaansen-Jenniskens, Dr Roberto Narcisi and Prof Gerjo JVM van Osch; the Chinese University of Hong-Kong, Hong-Kong, with Dr Kevin Ho and Prof Ling Qin, and the ARI, Switzerland, with Dr Andrea Schwab, Dr Matteo D'Este, Dr David Eglin, Prof Martin Stoddart, Prof Mauro Alini and Prof Geoff Richards with multidisciplinary expertise in materials, bioprinting, bioreactors, biomechanics, cell biology and immunology. The team is supported by Prof Peter Angele and Prof Peter Van der Kraan acting as advisory experts.

Multiple crosslinked bio-inks for 3D microextrusion of tissue-like constructs and biodegradable thermoplastic elastomer for fuse deposition manufacturing (Ongoing) (Multibio-Ink, CRP-OCD project) (D Eglin, M D'Este, M Stoddart, M Alini)

Biofabrication is providing scientists and clinicians the ability to produce engineered tissues with desired shapes, chemical and biological gradients. Typical resolutions achieved with extrusion based bioprinting are at the macroscopic level. However, for capturing the fibrillar nature of the extracellular matrix (ECM), it is necessary to arrange ECM components at smaller scales, down to the sub-micron and the molecular level.

In this project, we introduce a (bio)ink containing hyaluronan (HA) as tyramine derivative (THA) and collagen (Col). Similarly, to other connective tissues, in this (bio)ink Col is present in fibrillar form and HA as viscoelastic space filler. THA was enzymatically crosslinked under mild conditions allowing simultaneous Col fibrillogenesis, thus achieving a homogeneous distribution of Col fibrils within the viscoelastic HA-based matrix. THA-Col composite displayed synergistic properties in terms of storage modulus and shear-thinning, translating into good printability.

Shear-induced alignment of the Col fibrils along the printing direction was achieved and quantified via immunofluorescence and second harmonic generation (Figure 11.7.1). Cell-free and cell-laden constructs were printed and characterized, analyzing the influence of the controlled microscopic anisotropy on cell behavior and chondrogenic differentiation. THA-Col showed cell instructive properties modulating hMSC adhesion, morphology. Based on gene

expression of cartilage/bone markers and matrix production, hMSCs embedded into the bioink displayed chondrogenic differentiation comparable or superior to standard pellet culture by means of proteoglycan production (Safranin O staining and proteoglycan quantification) as well as increase in cartilage related genes.

The possibility of printing matrix components with control over microscopic alignment brings biofabrication one step closer to capturing the complexity of native tissues and the developed bioink can be integrated in the osteochondral implant of the OCD consortium.

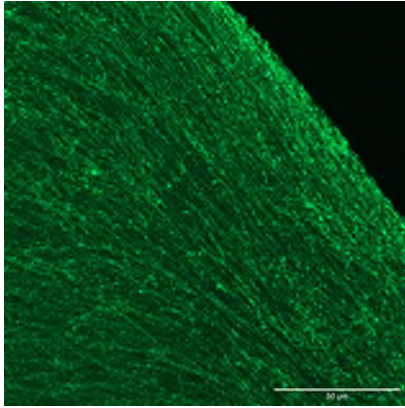

Figure 11.7.1: Representative images of shear-induced aligned collagen fibers in bioink matrix.

Pres:

Petta D, Grijpma DW, Alini M, Eglin D, D'Este M. 3D Printing of a Hyaluronan Bioink With Double Gelation Mechanism for Independent Tuning of Shear-Thinning and Shape Fixation, Stem Cell Biology & Technology. Royan International Twin Congress. Reproductive Biomedicine & Stem Cells, Tehran.

Schwab A, Ambrosio L, Alini M, Eglin D, D'Este M. Anisotropic properties of a hyaluronic acid collagen biomaterial ink to control cellular behavior, TERMIS EU, Rhodos, 2019, p. 1422 / 883 (eCM coll).

Schwab A, Ambrosio L, Alini M, Eglin D, D'Este M. Hyaluronic acid collagen biomaterial ink with anisotropic properties to control cellular organization, SSB+RM Swiss Conference on Biomaterials and Regenerative Medicine eCM Periodical: Abstract Collections Muttenz, 2019, p. p19.

Pub:

Davidson MD, Ban E, Schoonen ACM, Lee MH, D'Este M, Shenoy VB, Burdick JA. Mechanochemical Adhesion and Plasticity in Multifiber Hydrogel Networks, Advanced Materials epub Dec 18 (2019) e:1905719.

Partners:

- Malda J (Prof) and Levato R (PhD), The University Medical Center Utrecht, the Netherlands
- Bastiaansen-Jenniskens YM (PhD), Narcisi R (PhD) and van Osch G (Prof), The University Medical Center Rotterdam, the Netherlands
- Ho K (MD, PhD), Qin L (Prof, MD), Chinese University of Hong-Kong, Hong-Kong
- Burdick J (PhD), Mauck R (Prof), the University of Pennsylvania, USA

11.8 AO Development Incubator

Biphasic Plating – new stabilization concept to improve fracture healing (Biphasic Plate) (Ongoing) (L Hofmann-Fliri, M Windolf)

Background: Most bone fractures heal following implant fixation. However, healing complications may still occur in approximately 10% of the cases, whereof a significant portion can be attributed to unfavorable mechanical conditions at the fracture site. Moreover, state-of-the-art plates are prone to catastrophic failure from either excessive loading in the early post-operative phase or due to fatigue in combination with inadequate healing and load sharing in the late phase. A new plating concept, called biphasic plating, was proposed by ARI in collaboration with QUT (Brisbane, Australia) to enhance the existing treatment modalities of locked plating by redesigning the current bone plate. The biphasic plating concept was proven by mechanical testing and animal experiments. Robust callus formation was demonstrated in a sheep tibia defect model under varying fracture conditions and changing functional loading using a specially designed biphasic plate for sheep (Project 2Pinvivo).

Goal: To develop and obtain CE Mark of a biphasic anatomical plate for distal femur fractures as a pilot implant and to collect clinical evidence demonstrating the concept feasibility.

Results: Several activities regarding usability, performance and biocompatibility of the biphasic plate have taken place. The dynamic feature of the plate was redesigned for improved manufacturability. Mechanical testing of prototype plates demonstrated their more than double ultimate strength and more than 4 times longer fatigue life compared to a conventional LCP for the distal femur. Key opinion leaders have tested and approved the implant design in a wet lab. Design freeze was given by end of 2019, leading into verification and validation activities in the coming year and, hence, towards first applications in clinics.



Figure 11.8.1: Biphasic Plate for the distal femur.

Pres:

Gurung R, Windolf M, Schwyn R, Zeiter S, Epari D, Hofmann-Fliri L. Novel dynamic plating concept to improve the biomechanics of internal fixation. 2019. AO TAP Scientific Congress, Taipei, Taiwan (oral, best paper award).

Hofmann-Fliri L, Epari D, Schwyn R, Zeiter S, Windolf M. Biphasic Plating – In vivo study on a novel fixation concept to enhance mechanobiological fracture healing. 2019. EORS, Maastricht, Netherlands (oral).

Patents:

Windolf M, Epari D. Biphasic bone plate. CH01515/19

Partners:

- Epari D (Prof), Queensland University of Technology, Brisbane, Australia
- Schütz M (Prof), Jamieson Trauma Institute, Brisbane, Australia

AO Fracture Monitor (SmartPlate) (Ongoing) (M Ernst, M Windolf)

Background: Information on healing progression and load-bearing characteristics in fracture patients is only barely tapped due to the inaccessibility of a confined biological region and the limited value of radiographic methods. A novel approach to continuously measure both fracture healing and patient activity has been recently developed at ARI. The system comprises an implantable data logger for autonomous collection of relevant parameters to access fracture

healing. Wireless synchronization of the acquired healing data via patient's mobile phone allows for remote monitoring by the treating physician. Proof of concept is obtained from preclinical experiments and from first clinical data collection with prototype devices on external fixation (Project SmartFix).

Goal: The AO Fracture Monitor shall be further developed into a commercially applicable system for large fragment bridge plating. The implantable device plus the accompanying software shall be developed and tested according to the regulatory requirements and undergo clinical evaluation thereafter.

Results: A comprehensive refinement of the previous implant prototype has been finished in 2019, resulting in an implantable device that integrates well with the locking plate with minimal elevation over it. It is hermetically encapsulated in a metal enclosure and provides continuous healing data collection and processing approximately 6 months long. A cloud solution is currently being set up to store all patient data and to display the information in an intuitive way to the treating physicians.

The first 10 animals were operated in 2019 with the new implantable data logger attached to a 10-hole LCP bridging a tibial defect. The defect size ranges from 0.6 to 10 mm to generate different healing times. Up to now, all devices have operated flawlessly, delivering continuous healing data. The collected data demonstrates the capability of the fracture monitor to differentiate different stages of healing at an early phase. Monitoring will continue until the end of the implant's lifetime. Final evaluation will be performed 9 months post operation.

In parallel to the preclinical project part, the detailed design of the AO Fracture Monitor has been pushed forward so that it can be transferred for production process development and subsequent verification and validation, including the first application in a clinical trial.

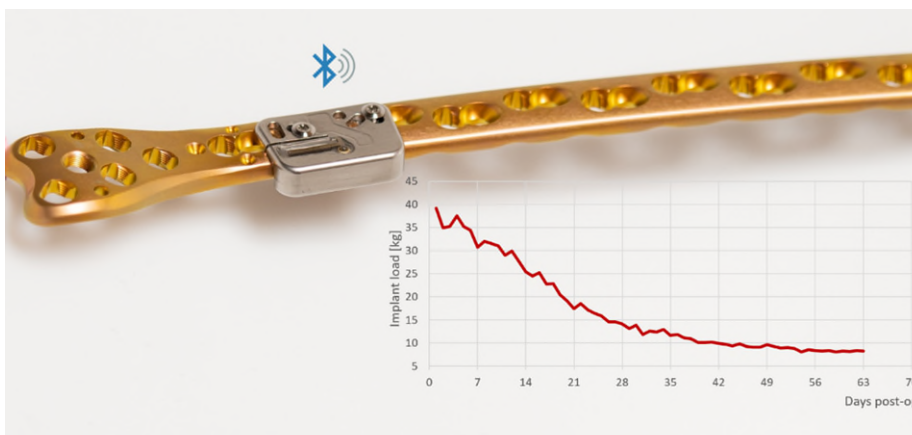

Figure 11.8.2: The AO fracture Monitor system visualized with an implantable datalogger mounted on a locking plate and system output graphics to judge healing (mobile phone and web application for data visualization not shown).

Pres:

Windolf M. Lessons in overcoming challenges—from the team that developed the AO Fracture Monitor, DKOU 2019, Berlin, Germany (invited oral).

Ernst M. AO Fracture Monitor and the necessity of translational medical education, sitem-insel School: Bringing Innovation to the Patient, 2019, Bern (oral).

Gueorguiev B. From Wearables to Smart Implants – AO Fracture Monitor to Assess Bone Healing, ICORS 2019, Montreal, Canada (oral).

Theses:

Comtesse S. Prediction of Interfragmentary Movement, Loading and Implant Strain based on Finite Element Modelling and Strain Measurements with the AO Fracture Monitor, MSc ETHZ Biomedical Engineering, 2019 (Ferguson SJ, Ernst M, Mischler D).

Patent:

Windolf M. Device for measuring, processing and transmitting implant parameters. CH01335/19.

Partner:

- Pohlemann T (Prof), University Clinic Saarland, Homburg, Germany

11.9 Extramural projects

Augmented screwdrivers reduce bone stripping rates and optimize tightness when inserting non-locking screws (TightRight) (J Fletcher, V Neumann, B Gueorguiev)

Background: Non-locking screws remain the most commonly used orthopedic implants, however they are often poorly inserted. Exceeding the stripping torque for a screw hole reduces pullout strength by more than 80%.

Goal: To quantify stripping rates and screw tightness for orthopedic trauma surgeons and assess how these change when using a screwdriver that indicates when optimum tightness is reached.

Results: At the AO Davos Courses, orthopedic trauma surgeons tightened 20 screws in two phases: (1) screws tightened to the surgeon's perception of optimum tightness, and (2) using an augmented screwdriver indicating when a predetermined optimum tightness – defined as 70% of the maximum stripping torque – was reached. Within each phase, 10 partially inserted 3.5 mm non-locking cortical screws were tightened through a 3.5 mm plate into 4 mm thick artificial bone analogue. The stopping torque for each screw was recorded and compared to the stripping torque; if the stopping torque greatly exceeded the stripping torque, tightness values higher than 100% were possible.

With a normal screwdriver, stripping rates were high, though varied greatly amongst surgeons. Using an augmented screwdriver greatly improved insertion, with optimum tightness being achieved alongside with a significantly reduced rate of bone stripping.

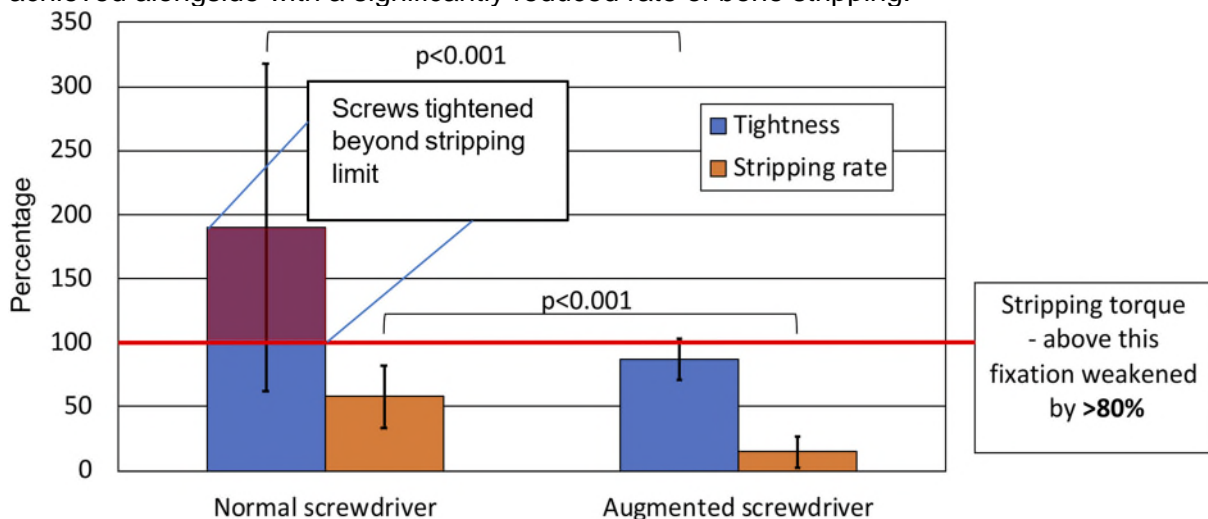

Figure 11.9.1: Average tightness and stripping rates when orthopedic trauma surgeons inserted 10 screws using normal and augmented screwdrivers.

Fund: Royal College of Surgeons, UK, GBP 5'000, Period: 2019.

Awards:

British Orthopaedic Research Society (BORS) and Bone Research Society (BRS), Cardiff, Wales, 4-6 September (2019), second prize for best podium presentation
London Shoulder Meeting (LSM), London, UK, 17 May (2019), the poster award

Pres:

Fletcher J, Neumann V, Silva J, Mys K, Panagiotopoulou V, Verschueren A, Gueorguiev B, Richards RG, Whitehouse M, Preatoni E, Gill H. TightRight: augmenting screwdrivers to reduce bone stripping rates and optimise tightness when used inserting non-locking screws. 2019 BORS BRS (oral)

Fletcher J, Neumann V, Wenzel L, Gueorguiev B, Richards RG, Whitehouse M, Gill H, Preatoni E. Assessing screw tightness and stripping rates achieved by orthopaedic surgeons and researchers. 2019 EFORT (poster)

Fletcher J, Neumann V, Silva J, Mys K, Panagiotopoulou V, Gueorguiev B, Richards RG, Whitehouse M, Preatoni E, Gill H. Augmented screwdrivers greatly reduce bone stripping rates and optimise tightness when used to insert non-locking screws. 2019 BOA (poster)
 Fletcher J, Neumann V, Wenzel L, Gueorguiev B, Richards RG, Whitehouse M, Gill H, Preatoni E. Assessing screw tightness and stripping rates achieved by orthopaedic surgeons and researchers. 2019 ICORS (poster)

Partners:

- Gill H (Prof), University of Bath, Bath, UK
- Preatoni E (MD), University of Bath, Bath, UK
- Whitehouse M, University of Bristol, Bristol, UK
- Verschueren A (MD), University of Bath, Bath, UK

Modeling of material injection processes into porous structures applied to vertebroplasty (CemFlow) (Ongoing) (D Gehweiler, E Zweifel, B Gueorguiev)

Background: Vertebroplasty has become an important technique for stabilization of osteoporotic vertebral fractures and other weakening lesions such as angioma or metastatic tumors. However, this procedure presents a significant risk through cement leakage that can result in serious complications such as pulmonary embolism or compressions of nerve roots or the spinal cord. Simulations of the bone cement injection processes could predict injection rates, injection pressures, bone cement distribution within the vertebra and the probability of cement leakage, thus providing a valuable risk assessment tool. However, risk assessment can only be performed if realistic simulations of the entire vertebra are performed.

Goal: To collect experimental data by means of quasi-continuous CT scanning and to model material injection processes applied to vertebroplasty describing bone cement flow behavior and distribution, biomechanical behavior at the interface between bone cement and trabecular structure, and bone cement curing.

Results: A bone cement injector was developed and used in the proof-of-concept experimental phase of the project. Polyurethane foam samples with structure similar to trabecular bone were injected with gelatin containing contrast medium instead of fast-hardening bone cement. The force applied to the plunger of the syringe during CT scanning was recorded at 10 Hz. An animation of the 3D cement expansion was created from the recorded CT image data and will serve for parametrization and validation of the numerical models at University of Stuttgart.

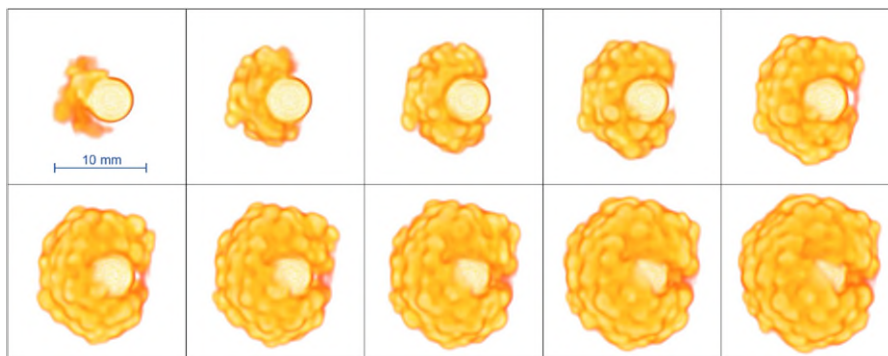

Figure 11.9.2: Visualization of CT scanned bone cement-like contrast agent injection into polyurethane foam at a rate of 0.4 s.

Fund: German Research Foundation (DFG), Special Research Area (SFB), ARI funding: EUR 100'000, Period: 2018-2021.

Partners:

- Röhrle O (Prof), University of Stuttgart, Germany
- Wagner A, University of Stuttgart, Germany
- Trivedi Z, University of Stuttgart, Germany

Cone-beam computed tomography – a fast and promising technique for microstructural imaging in clinical practice (K Mys, P Varga)

Background: Obtaining high-resolution CT scans for clinical applications is challenging. However, it could help better understand and treat such bone diseases as osteoporosis. High-resolution peripheral computed tomography (HR-pQCT) is considered the best technique *in vivo*. However, a breakthrough for clinical practice is lacking due to a relatively long acquisition time, which inhibits scanning of large field of view (FOV) *in vivo*. A promising alternative is the high-resolution cone-beam computed tomography (CBCT), which is already the gold standard in many dental and maxillofacial applications. The top high-resolution CBCT scanners on the market (eg., Newtom 5G) feature a fast scanning time (18 à 31s), a large FOV (12x12x8cm³)

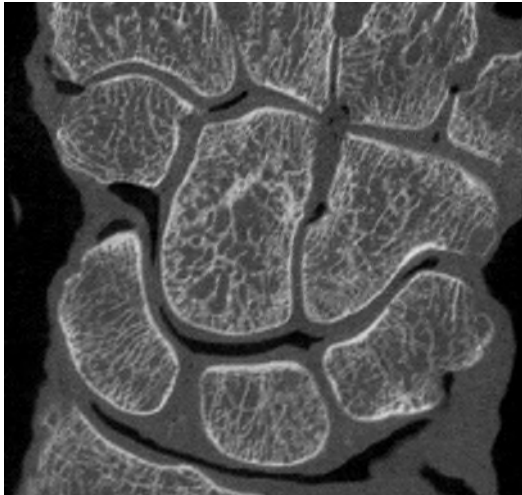

Figure 11.9.3: CBCT scan of whole cadaver wrist processed with in-house developed software

and a low radiation dosage, in addition to a high resolution (voxel size down to 75µm). Yet, CBCT is impaired by the presence of image artefacts that reduce image contrast, leading to it being currently used for qualitative evaluation only.

Goal: To determine whether CBCT can be enhanced by means of artefact correction algorithms and advanced segmentation techniques in order to be used to visualize and quantify both bone microstructure and mechanical parameters in clinical practice.

Results: CBCT enables fast scanning of large FOV of extremities at high spatial resolution. In addition, the enhanced CBCT images had a very comparable accuracy with HR-pQCT when quantifying bone microstructural and mechanical parameters. When enhanced, high-resolution CBCT is an attractive and promising imaging tool that can be used in the clinical treatment of several bone and joint diseases.

Fund:

KU Leuven internal funding and the Swiss National Supercomputing Centre under project ID 593, ARI funding: EUR 7'000, Period: 2019

Pres:

Mys K, Zhang G, Stockmans F, Wyers CE, van den Bergh JPW, van Lenthe GH. X-Ray Scattering Is Limited in Cone-Beam Computed Tomography of Extremities. 2019 QMSKI, Lake Louise, Canada (oral)

Mys K, Varga P, Stockmans F, Gueorguiev B, Wyers CE, van den Bergh JPW, van Lenthe GH. Cone-Beam Computed Tomography as a Fast Alternative for High-Resolution Peripheral Computed Tomography. 2019 QMSKI, Lake Louise, Canada (oral)

Mys K, Varga P, Stockmans F, Gueorguiev B, Wyers CE, van den Bergh JPW, van Lenthe GH. Influence of the Analysis Software to Calculate Direct Bone Structural Parameters. 2019 QMSKI, Lake Louise, Canada (poster)

Mys K, Varga P, Stockmans F, Gueorguiev B, Neumann V, Vanovermeire O, Wyers CE, van den Bergh JPW, van Lenthe GH. Cone-beam CT as a fast and promising technique to assess the microstructure of distal radii in clinical practice. 2019, ESB, Vienna, Austria (oral)

Pub:

Mys K, Varga P, Gueorguiev B, Hemmatian H, Stockmans F, van Lenthe GH. Correlation between cone-beam computed tomography and high-resolution peripheral computed tomography for assessment of wrist bone microstructure, J Bone Miner Res. 2019,34:867-874

Mys K, Varga P, Gueorguiev B, Hemmatian H, Stockmans F, van Lenthe GH. Reply Letter to the editor: Clinical *In Vivo* Assessment of Bone Microarchitecture with CT Scanners: An enduring challenge, J Bone Miner Res. 2019

Mys K. Cone-beam computed tomography is a fast and promising technique for microstructural imaging in clinical practice, PhD thesis, 2019

Partners:

- Van Lenthe GH (Prof), KU Leuven, Leuven, Belgium
- Stockmans F (Prof), KU Leuven Kortrijk, Kortrijk, Belgium

Stability of externalized locked plating of unstable proximal tibia fractures under partial weightbearing (I Zderic, B Gueorguiev, P Varga)

Background: Osteosynthesis of high-energy metaphyseal proximal tibia fractures is still challenging, especially in patients with severe soft tissue injuries and/or short stature. Although the use of external fixators is the traditional treatment of choice for open comminuted fractures, patients' acceptance is low due to the high profile and therefore the physical burden of the devices. Recently, clinical case reports have shown that supercutaneous locked plating used as definite external fixation could be an efficient alternative.

Goal: To evaluate the effect of implant configuration on stability and interfragmentary motions of unstable proximal tibia fractures fixed by means of externalized locked plating.

Results: A finite element model of unstable proximal tibia fracture AO 41-C2.2, simulated via 2 cm osteotomy gap located 5 cm distally to the articular surface, was developed based on CT scan of a 48 years-old male donor, to compare the stability of one internal and two different externalized plate fixations with a medial stainless steel LISS-DF plate: (1) with 2 mm plate elevation (internal locked plating), (2) with 22 mm plate elevation (externalized locked plating with thin soft tissue simulation), and (3) with 32 mm plate elevation (externalized locked plating with thick soft tissue simulation). Axial loads of 25 kg (partial weightbearing) and 80 kg (full weightbearing) were virtually applied to the proximal tibia end and distributed at a ratio of 80% to 20% on the medial and lateral condyles, respectively.

From virtual biomechanics point of view, externalized locked plating of unstable proximal tibia fractures with simulated thin and thick soft tissue environment seems to ensure favorable conditions for callus formation with longitudinal strains at the fracture site not exceeding 10%, thus providing appropriate relative stability for secondary bone healing under partial weightbearing during the early postoperative phase.

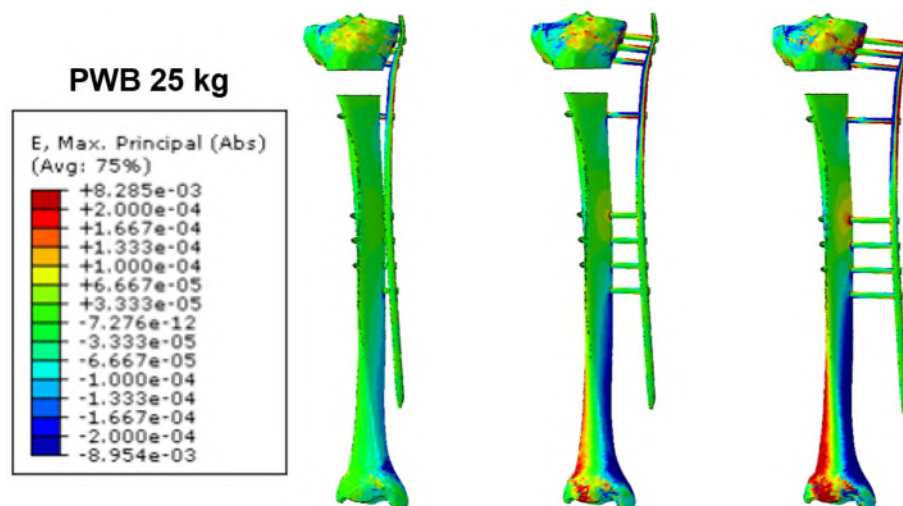

Figure 11.9.4: Visualization of the finite element results for internal locked plating (left) and externalized locked plating with thin (middle) and thick (right) soft tissue simulation, demonstrating the effect of plate elevation on induced deformations under 25 kg partial weightbearing (PWB).

Fund:

Trakia University, Stara Zagora, Bulgaria, EUR 2'500. Period: 2017

Pres:

Makelov B, Silva JD, Apivatthakakul T, Gueorguiev B, Varga P. Externalized locked plating of unstable proximal tibia fractures can provide sufficient stability under partial weightbearing – a finite element study. 2019, EFORT, Lisbon, Portugal (oral)

Makelov B, Zderic I, Silva JD, Apivatthakakul T, Gueorguiev B, Varga P. Externalized locked plating of unstable proximal tibia fractures can provide sufficient stability under partial weightbearing – a finite element study. 2019, EORS, Maastricht, Netherlands (oral)

Makelov B, Silva JD, Apivatthakakul T, Gueorguiev B, Varga P. External one-staged locked plating of unstable proximal tibia fractures can provide callus formation and sufficient stability under partial weightbearing – a finite element study. 2019, BOTA, Varna, Bulgaria (poster)

Pub:

Makelov B, Silva JD, Apivatthakakul T, Gueorguiev B, Varga P. Externalized locked plating of unstable high energy proximal tibia fractures – a FEA Study, *Bul J Ortop Trauma*. 2019,56(3):124-138

Makelov B, Silva JD, Apivatthakakul T, Peeva K, Kavrykov T. Externalized metaphyseal locked plating of complex proximal tibial fractures – clinical and biomechanical outcomes, *J Science & Research*. 2019,3(1):55-66

Partners:

- Makelov B (MD), University Multiprofile Hospital for Active Treatment 'Prof Stoyan Kirkovitch', Stara Zagora, Bulgaria
- Apivatthakakul T (Prof), Chiang Mai University Hospital, Thailand
- Silva JD, Karl Landsteiner Privatuniversität für Gesundheitswissenschaften, Austria

Personalized Ceramic Printable Ink for Patient Specific Implant Fabrication (InCePt) (D Eglin, G Richards)

The aim of this project was to develop and commercialize a chairside CAD/CAM solution for use in CMF indications. This innovative solution rested on the freeform fabrication process (bioprinting) developed by regenHU Ltd and a proprietary hydraulic calcium phosphate ink. In collaboration with ARI and University of Berne, the technology which is currently in a pre-prototype phase was physically and clinically assessed in order to gain market approval. One of the crucial goals given to the ARI team was to develop a formulation ink product for chairside manufacturing solution.

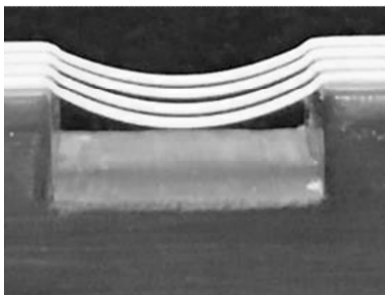
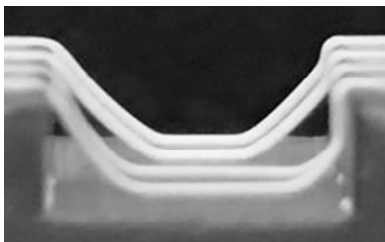

A novel printing approach was developed focusing on improving the shape fidelity of the printed cement past. The initial rationale was that: by achieving a high accuracy and shape fidelity of the printed structures, i) better control over the overall shape will be achieved, ii) better control over the mechanical properties obtained and iii) better ability to assemble ceramic printed structure with personalized implants or others mechanically or biological relevant printed structures. The main scientific concept developed here was to use a co-axial extrusion technology for the printing of the reactive cement with a solvent or a mixture of solvents to initiate hardening of the extruded cement past and its stability during the printing step (Figure 11.9.5).

Figure 11.9.5: Initial stability of Calcium Phosphate cement ink upon printing without and with solvent-coaxial printing

Fund: CTI/KTI (nr 18060.2), ARI Funding: CHF 292'700, Period: 2017-2019.

Pres:

Sprecher CM, Thurner M, Büchler P, Richards RG, Eglin D. Improved post-processing stability of a 3D printed cement paste via co-axial extrusion of organic solvents. 2018 SSB+RM (poster).

Partners:

- Thurner M, RegenHU Ltd, Villaz-Saint-Pierre, Switzerland
- Büchler P, Institute for Surgical Technology & Biomechanics, University of Bern, Switzerland
- Lieger O (MD), Department of Cranio-Maxillofacial Surgery, Inselspital, University Hospital Bern, University of Bern, Switzerland

3D Sound Induced Morphogenesis (3D-SIM) (T Serra)

Throughout the BRIDGE funding period, a novel 3D cell technology, named 3D Sound Induced Morphogenesis (3D-SIM) was developed. More specifically, the generation of a first 3D-SIM prototype to be: 1/ easily implemented into laboratory environment (small, portable, suitable for sterile setting), 2/ affordable and user friendly, and 3/ able to create 3D cell models in a time effective manner, with sufficient spatial complexity, retaining cell viability was achieved. Finally, functionality evaluation of 3D-SIM tech was done through a proof of concept in vitro cell model: a 3D vascularized construct. The patent: "Surface Acoustic Wave (SAW) 3D-Printing Method", filed in August 2017, was further improved with detailed data from BRIDGE project and submitted to the international patent application (PCT) published in February 2019. Moreover, to get more visibility, both in the industrial and academic environment, outcomes from the project have been presented in different international conferences such as the TERMIS-EU in Rhodes, the European Society of Biomaterials in Maastricht, the International Society of Biofabrication in Wurzburg where the first prize for outstanding achievements in the field of biofabrication and 3D cell assembly was given to the project. A start-up company, named MimiX Biotherapeutics Ltd was created in Autumn 2019. BRIDGE (nr 20B1-1_178259) CHF 130'000, Period: 2018-2019.

Fund: BRIDGE (nr 20B1-1_178259) CHF 130'000, Period: 2018-2019.

Pres:

Pellicciotta D, Richards RG, Eglin D, Alini M, Serra T. A sound-induced technology for multiscale organization of perfusable micro-vessels networks TERMIS EU, Rhodos, 2019, p. 1358 / 819 (eCM coll).

Serra T, Pellicciotta D, Basoli V, Della Bella E, Armiento AR, Richards RG, Alini M, Eglin D. Spatially orchestrated micro-vessels networks via acoustic waves cell patterning, SSB+RM Swiss Conference on Biomaterials and Regenerative Medicine eCM Periodical: Abstract Collections Muttentz, 2019, p. 10.

Serra T. A sound-induced technology for multiscale orchestration of functional vessels networks, ATSM 1st Advanced Therapies Science Meeting, Berlin, 2019.

Serra T. A sound-induced technology for multiscale organization of perfusable micro-vessels networks, EMBL Symposium: Synthetic Morphogenesis, Heidelberg, 2019.

Partners:

- Moretti M (PhD), Swiss Institute for Regenerative Medicine, Switzerland
- de Bruijn J (Prof), Kuros Biosciences, Switzerland
- Millan C (PhD), CellSpring, Switzerland

Biofabrication of cartilage particulate microtissues laden hyaluronan tissue engineered constructs (SSSTC EG 08-122016) (D Eglin)

In this project, we optimized the production of electrosprayed human bone marrow stromal cell (hBMSCs)-embedded alginate-gelatin (Alg-Gel,) microspheres for the purpose of their assembly in a 3D-printed poly(ϵ -caprolactone) (PCL) scaffold for the fabrication of a mechanically stable and biological supportive tissue engineering cartilage construct. Optimization of hBMSC-embedded Alg-Gel microspheres produced by electrospray has been performed (Figure 11.9.6). The Alg-Gel composition selected allowed the conservation of hBMSC viability and supports proliferation and matrix deposition. The possibility to seed and assemble microspheres in designed 3D-printed PCL scaffolds for the fabrication of a mechanically stable and biological supportive tissue engineering cartilage construct was demonstrated. We optimize and demonstrate that electrospray microsphere fabrication is a cytocompatible and facile process to produce the hBMSC-embedded microsize tissue-like particles that can easily be assembled into a stable construct. This finding could have application in the development of mechanically competent stem cell-based tissue engineering of cartilage regeneration

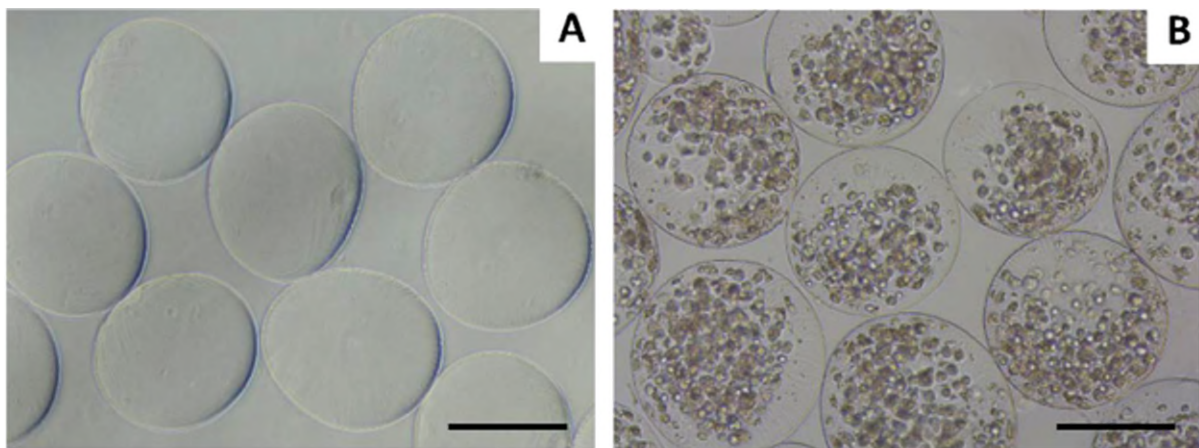

Figure 11.9.6. Representative microscopy images of optimized Alg-Gel microspheres (A) without hBMSCs and (B) containing hBMSCs produced using the optimized electrospray protocol

Fund: SSSTC exchange (nr EG 08-122016), Funding: CHF 30'000 Period: 2018-2019.

Pub:

Xu Y, Peng J, Richards RG, Lu S, Eglin D. (2019). Optimization of electrospray fabrication of stem cell-embedded alginate-gelatin microspheres and their assembly in 3D-printed poly (ϵ -caprolactone) scaffold for cartilage tissue engineering. *Journal of Orthopaedic Translation*, 18, 128-141.

Partner:

- Peng J (Prof, MD), the Institute of Orthopedics, Peking Key Lab of Regenerative Medicine in Orthopaedics, Key Lab of Chinese PLA, Chinese PLA General Hospital, People's Republic of China

The tissue-Renin-Angiotensin-System in degenerated intervertebral disc (RenoDisc) (Z Li, S Grad)

Background: Intervertebral disc (IVD) degeneration causes back pain which accounts for significant global socioeconomic burden. Recently, the expression of the tissue-Renin-Angiotensin-System (tRAS) in rat and bovine IVD was demonstrated. The major effector of tRAS is Angiotensin II (AngII), which participates in proinflammatory pathways.

Goal: As inflammation contributes to IVD degeneration, the present study sought to investigate the expression of tRAS in the human IVD, and the correlation between tRAS, inflammation, and degeneration in human IVD tissue.

Results: Gene expression of tRAS components such as angiotensin-converting-enzyme (ACE), Ang II receptor type 2 (AGTR2), angiotensinogen (AGT), and cathepsin D (CTSD) was confirmed in human IVDs (Figure 11.9.7 left). IVD samples that expressed tRAS components (n=21) revealed significantly higher expression levels of interleukin 6 (IL-6), tumour necrosis factor α (TNF- α), a disintegrin and metalloproteinase with thrombospondin motifs (ADAMTS) 4 and 5 compared to tRAS-negative samples (n=37) (Figure 11.9.7 right). Furthermore, within tRAS-positive samples, AGT, Matrix-Metalloproteinases 13 and 3, IL-1, IL-6, and IL-8 were expressed significantly more highly in traumatic compared to degenerated IVDs. Biochemical analysis of IVD tissue revealed significantly higher total GAG/DNA content of non-tRAS expressing IVD tissue compared to tRAS positive tissue. Immunohistochemistry confirmed the presence of AngII in the human IVD. This study identified the existence of tRAS in the human IVD and suggests a correlation between tRAS expression, inflammation, and ultimately IVD degeneration.

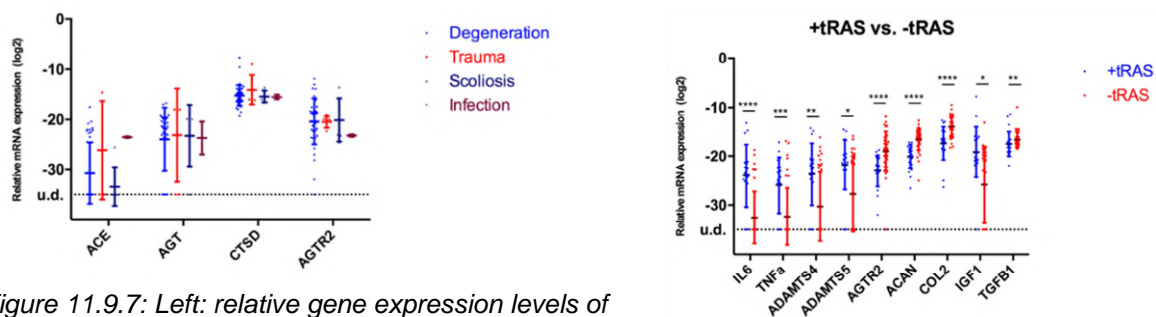

Figure 11.9.7: Left: relative gene expression levels of tRAS factors classified by diagnosis. Right: relative gene expression levels of catabolic, anabolic and proinflammatory genes in human IVDs classified by tRAS expression.

Fund: funded by German Spine Society, EUR 23'000, period: 01.01.2016-30.09.2019

Pres:

"Pre-clinical testing of anti-inflammatory compounds in an intervertebral disc organ culture model", BioSpine, 2019 April 3-5, Rome, Italy – Zhen Li (oral)

"Preclinical Testing of Anti-Inflammatory Compounds Using a Whole Intervertebral Disc Organ Culture Model". Global Spine Congress, 2019 May 15-18, Toronto, Canada – Sibylle Grad (oral)

"The Tissue-Renin-Angiotensin-System of the Human Intervertebral Disc", ORS 2019, Austin, US – Gernot Lang (poster)

Pub:

Pfannkuche J-J, Guo W, Cui S, Ma J, Lang G, Peroglio M, Richards RG, Alini M, Grad S, Li Z. Intervertebral disc organ culture for the investigation of disc pathology and regeneration – benefits, limitations, and future directions of bioreactors. Connective Tissue Research 2019, 26(9):1-18.

Partners:

- Lang G (MD), Albert-Ludwigs-Universität Freiburg, Freiburg, Germany
- Südkamp N (Prof), Albert-Ludwigs-Universität Freiburg, Freiburg, Germany

Targeting cartilage regeneration in joint and intervertebral disc diseases (TargetCaRe) (S Grad, M Alini)

Background and aim: The aim of the project TargetCaRe (Targeting cartilage regeneration in joint and intervertebral disc diseases) was to achieve regeneration of damaged and degenerated cartilage and disc by employing targeting strategies tailored to the pathology and the tissues involved. Towards this aim ARI scientists collaborated with experts in advanced drug delivery carriers with dedicated targeting tools, state of the art imaging techniques, and cartilage or disc biology. Regeneration of diseased tissues was addressed by loading biologically active agents in state-of-the-art nanocarriers.

Results: A collaborative study aimed to test the interplay between mechanical and fibroblast growth factor (FGF)-18 mediated biochemical signals on the proliferation and differentiation of primary bovine articular chondrocytes embedded in a chondro-conductive Fibrin-Hyaluronan (FB/HA) based hydrogel. Chondrocytes seeded in a FB/HA hydrogel, with or without a chondro-inductive FGF18 variant were loaded within ARI's joint-mimicking bioreactor applying controlled, multi-axial movements, simulating the natural movements of articular joints.

Under moderate loading, samples produced significant amounts of sulphated glycosaminoglycan (sGAG)/DNA compared to unloaded controls. There was no significant effect of FGF-18 on cartilage gene expression at rest. Following moderate multi-axial loading, FGF-18 upregulated the expression of Aggrecan, Cartilage Oligomeric Matrix Protein, type II collagen and Proteoglycan-4. Moreover, the combination of load and FGF-18, significantly downregulated Matrix Metalloproteinases-9 and -13, two of the most important factors contributing to joint destruction in osteoarthritis. Thus, biomimetic mechanical signals and FGF-18 may work in concert to support hyaline cartilage regeneration and repair.

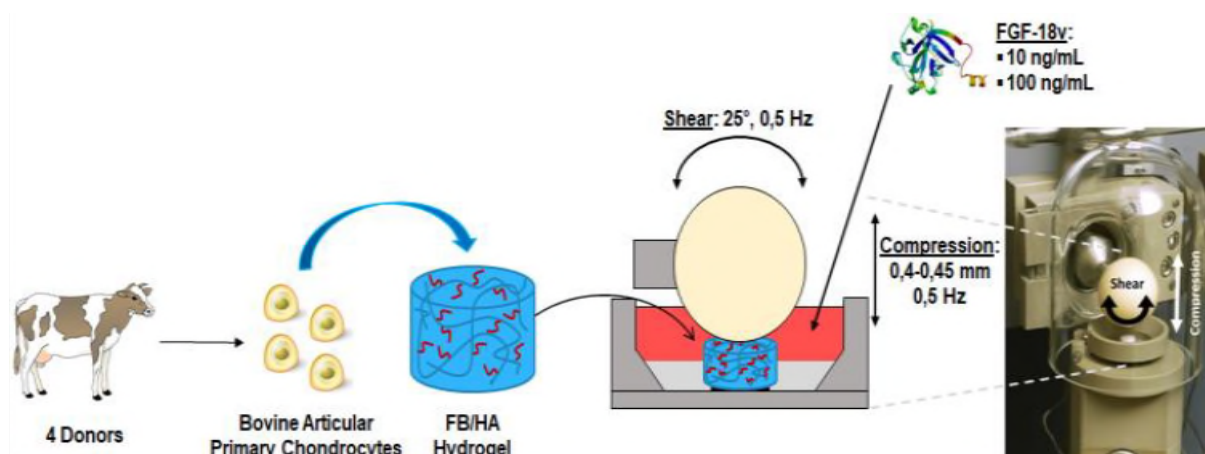

Figure 11.9.8: Design of the study. Articular bovine chondrocytes, isolated from fetlock joints, were embedded into FB/HA hydrogels and subjected to mechanical stimulation for 14 days. In addition, FGF-18 was added to the culture medium

Fund: EU H2020-MSCA-ITN-2014 Marie Skłodowska-Curie Grant ARI Funding CHF 530'000, Period: 2015-2019

Pub:

Haeckel S, Zolfaghar M, Du J, Hoppe S, Benneker LM, Garstka N, Peroglio M, Alini M, Grad S, Yayon A, Li Z. Fibrin-hyaluronic acid hydrogel with Fibroblast Growth Factor-18 for in vitro 3D culture of human and bovine nucleus pulposus cells. *Int. J. Mol. Sci.* 11:20(20), 2019.
Vainieri ML, Lolli A, Kops N, D'Atri D, Eglin D, Yayon A, Alini M, Grad S, Sivasubramanian K, van Osch GJVM. Evaluation of biomimetic hyaluronic-based hydrogels with enhanced endogenous cell recruitment and cartilage matrix formation. *Acta Biomater.* 2019 Nov 11. pii: S1742-7061(19)30755-X. doi: 10.1016/j.actbio.2019.11.015. [Epub ahead of print].

Pres:

Haeckel S, Li Z, Zolfaghar M, Yayon A, Hoppe S, Benneker LM, Alini M, Grad S. One-way Street Disc Degeneration? An Investigation of Hydrogel and Fibroblast Growth Factor 18 (FGF-18) for Intervertebral Disc Regeneration. DKOU 2019, Berlin, DE (podium)

S. Haeckel, Z. Li, A. Yayon, S. Hoppe, L. Benneker, M. Alini, S. Grad. One-way Street Disc Degeneration? An Investigation of Hydrogel and Fibroblast Growth Factor 18 (FGF-18) For Intervertebral Disc Regeneration. Global Spine Congress 2019, Toronto, CA (poster)

ML Vainieri, A Lolli, K Sivasubramaniyan, D Eglin, A Yayon, M Alini, S Grad, G Van Osch. Biomimetic hyaluronic-based hydrogel enhances endogenous cell recruitment and healing process of osteochondral lesions. TERMIS-EU 2019, Rodos, GR (podium)

Bernardo P. Antunes, M. Letizia Vainieri, Efrat Monsonego-Ornan, Mauro Alini, Sibylle Grad, Avner Yayon. Effects of mechanical stimulation combined with FGF-18 on bovine chondrocytes embedded in a novel Fibrin:Hyaluronan hydrogel. ORS 2019, US (poster)

Sonja Häckel, Mona Zolfaghar, Jie Du, Sven Hoppe, Lorin M. Benneker, Marianna Peroglio, Mauro Alini, Sibylle Grad, Avner Yayon, Zhen Li. Fibrin-hyaluronic acid hydrogel and Fibroblast Growth Factor-18 for Intervertebral Disc Regeneration: an *in vitro* study on bovine and human nucleus pulposus cells. ORS PSRS 2019, Skytop, USA (poster)

Partners:

- van Osch G (Prof), Erasmus University Medical Centre, NL
- Creemers L (PhD), University Medical Centre Utrecht, NL
- Machluf M (Prof), Technion-Israel Institute of Technology, IL
- Stevens M (Prof), Imperial College London, UK
- de Bari C (Prof), University of Aberdeen, UK
- Howard K (Prof), University of Aarhus, DK
- Heeren R (Prof), Fundamenteel onderzoek der Materie, NL
- Chan A (PhD), Percuros BV, NL
- Caterson B (Prof), Cardiff University, UK
- Yayon A (PhD), ProCore, IL
- Savelsberg R, Omics2Image, NL
- Lether I (MSc), Dutch Arthritis Foundation, NL

Traditional Chinese Medicine compound delivery system for treatment of osteoarthritis (TCM-OA) (M Alini, S Grad, M Stoddart)

Background and aim: Osteoarthritis (OA) is the most prevalent degenerative joint disorder that affects millions of patients worldwide. There is currently no effective and standardised treatment available, neither for repair nor for prevention of onset or progression of this disease. In this study, 40 Traditional Chinese Medicine (TCM) compounds were screened for potential anabolic and anti-inflammatory properties on human OA chondrocytes

Results: After induction of inflammation in our *in vitro* model, pro-inflammatory and catabolic genes were upregulated, and extracellular matrix content was decreased. After two weeks of treatment with certain compounds (Vanilic acid, Epimedin C, Psoralidin, Protocatechuicaldehyde, 4-Hydroxybenzoic acid and 5-Hydroxymethylfurfural), extracellular matrix was restored compared with the negative control group. Immunohistochemistry and Safranin-O staining confirmed superior amounts of cartilaginous matrix in treated pellets.

The compounds also exhibited anti-catabolic and anti-inflammatory effects and prevented the upregulation of pro-inflammatory markers including metalloproteinases and cyclooxygenase 2. Pathway analysis by bioinformatics tools, analyzing the most potent compounds, showed that osteoarthritic and inflammatory pathways tended to be downregulated. In conclusion, Vanilic acid and Epimedin C showed promising anti-inflammatory and anabolic effects in our inflammatory model on human OA chondrocytes. A local drug delivery system for the bioactive compound is envisioned and their efficacy for cartilage repair will be tested.

Fund: Swiss-China Joint project (SNF) ARI funding: CHF 250'000, Period: 2015-2019

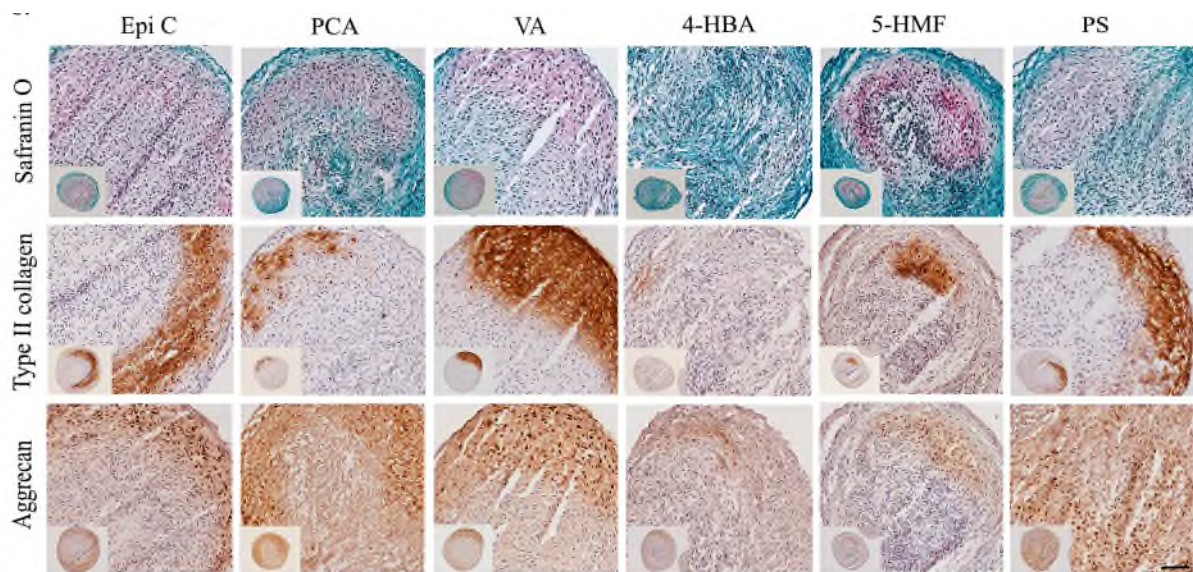

Figure 11.9.9: Histological and immunohistochemical characterization of cell pellets from OA chondrocytes in the inflammatory model. Safranin-O staining, collagen II and aggrecan immunostaining of pellets after 14 days of treatment with compounds. Scale bars = 100 μ m.

Pres:

Ziادلou R, Grad S, Stoddart M, Wang X, Qin L, Barbero A, Martin I, Alini M. Regulation of Inflammatory Response by Novel Herbal Small Molecules in Human Osteoarthritic Chondrocytes. TERMIS-EU 2019, Rhodes, GR

Pub:

Cao H-J, Li C-R, Wang L-Y, Ziادلou R, Grad S, Zhang Y, Cheng Y, Lai Y-X, Yao X-S, Alini M, Qin L, Wang X-L. Effect and mechanism of psoralidin on promoting osteogenesis and inhibiting adipogenesis. *Phytomedicine* 152860, 2019.

Zhang S, Hu P, Liu T, Li Z, Huang Y, Liao J, Hamid MR, Wen L, Wang T, Mo C, Alini M, Grad S, Wang T, Chen D, Zhou G. Kartogenin hydrolysis product 4-aminobiphenyl distributes to cartilage and mediates cartilage regeneration. *Theranostics*. 21;9(24):7108-7121, 2019.

Ziادلou R, Barbero A, Stoddart MJ, Wirth M, Li Z, Martin I, Wang XL, Qin L, Alini M, Grad S. Regulation of Inflammatory Response in Human Osteoarthritic Chondrocytes by Novel Herbal Small Molecules. *Int J Mol Sci*. 20(22). pii: E5745, 2019.

Partners:

- Martin I (Prof), University of Basel, CH
- Wang X (PhD), Shenzhen University, PR China
- Qin L (Prof), The Chinese University of Hong Kong, HK
- Lai Y (PhD), Shenzhen University, PR China
- Huang Y (PhD), Shanghai Institute for Biological Sciences, PR China

Induced pluripotent stem cell-based therapy for spinal regeneration (iPSpine) (Ongoing) (S Grad, M Alini)

Background and aim: This multicentre project aims to develop and demonstrate the Proof-of-Concept for a novel induced pluripotent stem cell (iPSC)-based therapeutic strategy as a regenerative therapy. iPSpine is targeting a societal challenge affecting millions of people, i.e. low back pain caused by intervertebral disc degeneration. The *iPSpine* team will: 1)

differentiate iPSCs towards notochordal-like cells which are specialised tissue specific progenitor cells with a critical role in rejuvenating the intervertebral disc; 2) develop smart biomaterials as a conductive microenvironment to prime iPSCs towards notochordal-like cells and instruct intervertebral disc regeneration, and 3) demonstrate the safety and efficacy of the *iPSpine* advanced therapy in clinically relevant pre-clinical models.

Fund: EU H2020-SC1-BHC-2018-2020 RIA- Grant; ARI Funding EUR 491,250; Period: 2019-2023

Pub:

Frauchiger DA, Tekari A, May RD, Džafo E, Chan SC, Stoyanov J, Bertolo A, Zhang X, Guerrero J, Sakai D, Schol J, Grad S, Tryfonidou MA, Benneker LM, Gantenbein B. FACS is more potent to fish IVD progenitor cells than magnetic and bead-based methods. *Tissue Eng Part C Methods* 25(10):571-580, 2019.

Partners:

- Tryfonidou M (Prof), University of Utrecht, NL
- Creemers L (PhD), University Medical Centre Utrecht, NL
- Ito K (Prof), Technical University of Eindhoven, NL
- Guicheux J (Prof), University of Nantes, FR
- Pandit A (Prof), National University of Galway, IE
- Wilke H-J (Prof), University of Ulm, DE
- Gantenbein B (Prof), University of Bern, CH
- Jorgensen C (Prof), Institute National de la Sante, FR
- Templin M, Naturwissenschaftliches und medizinisches Institut, DE
- Le Maitre C (Prof), Sheffield Hallam University, UK
- Vadala G, University Campus Biomedico, Rom, IT
- De Boer M, Ntrans Technologies, NL
- Noel D, University of Montpellier, FR
- Isasi R, University of Miami, US
- Kienle A, Spineserv Gmbh, DE
- Chan D, The University of Hong Kong, HK
- Buljovic Z, Pharmalex Gmbh, DE
- Lether I, National Reumafonds, NL

In-JOINT APPLication of non-viral mRNA therapy for OsteoArthritis (Joint-Approach) (Ongoing) (S Grad, M Alini)

Background and aim: Osteoarthritis (OA) is characterized by chronic joint pain and functional impairment and imposes a huge burden on the individual patient and health care systems. Current treatments relieve symptoms, but do not counteract disease progression. Intra-articular (in-joint) gene therapy-like mRNA therapy offers a promising highly innovative solution for the treatment of OA.

Despite their great promise, most of the current OA gene therapies rely on viral vectors for transfection, which are associated with high safety risks and costs, and have low transfection rates due to poor penetration in the extracellular matrices of joint tissues. This project proposes a novel approach, using polymer nanoparticle-based delivery of stabilized mRNA candidates. The patented nanotechnology of 20MED is combined with the proprietary stabilized non-immunogenic mRNA technology of ETHRIS, to deliver a non-viral mRNA-based 'transcript therapy' for injection into the joint. The preclinical efficacy will be tested in ex-vivo joint bioreactors and rat disease models by ARI and Paracelsus Medical University. The aim is to generate preclinical data with proof of concept for the novel mRNA transcript therapy.

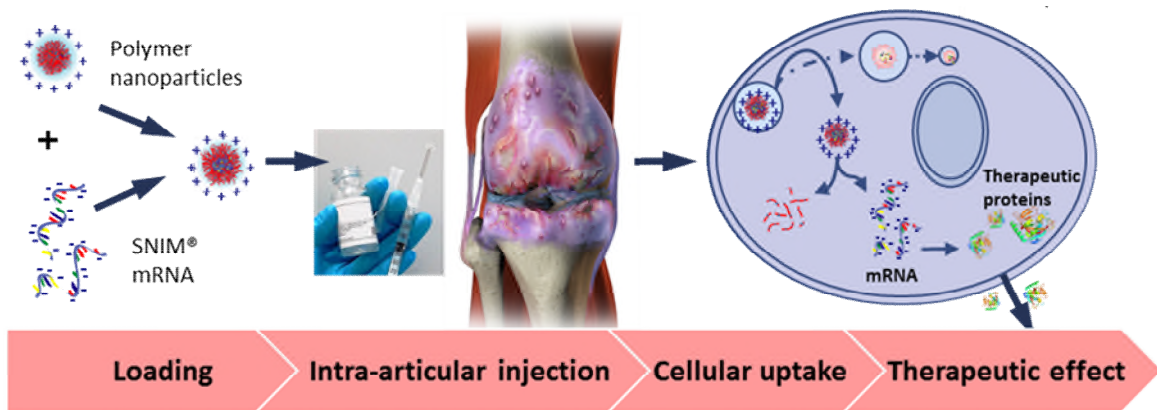

Figure 11.9.10: The Joint-Approach project proposes a novel approach to OA treatment using polymer nanoparticle-based delivery of stabilized mRNA factors into the joint. The unique nanotechnology developed by 20MED is combined with the proprietary stabilized non-immunogenic mRNA technology by Ethris, to deliver an mRNA-based 'transcript therapy'.

Fund: Eurostars; ARI Funding EUR 200,000; Period 2019-2022.

Partners:

- Engbersen J, 20Med Therapeutics, NL
- Planck C, Ethris GmbH, DE
- Traweger A, Paracelsus Medical University, AT

Identifying novel therapeutic targets for articular cartilage repair (STEMSEC) (M Stoddart)

Background: Novel therapies for cartilage regeneration have had limited success. Chondrogenic differentiation of mesenchymal stem cells (MSCs) under load is different to that observed during classical static culture conditions. This is highly clinically relevant, considering that patients receive weight-bearing rehabilitation therapy following cartilage repair. Additionally, as most *in vitro* cartilage repair studies are performed under static conditions, the lack of mechanical stimulation may explain why it has been challenging to reproduce promising *in vitro* results *in vivo*. Marrow stimulation techniques, such as microfracture, are the most commonly used clinical approach for cartilage repair with unpredictable results. Using a unique *in vivo* kinematic joint simulating bioreactor, we have previously shown that while complex multiaxial load induces hMSC chondrogenesis, it also induces the expression of a number of soluble molecules not typically found under static culture conditions. This identified novel mechanically induced targets, such as nitric oxide (NO), that are potentially clinically relevant. Within this project we aim to better understand the role of mechanical load on the molecules induced during human MSC chondrogenesis vs standard conditions (static and with TGF-beta). We will identify new potential treatment targets, while investigating the biological function of nitric oxide.

Goal: This project aims to establish the functional modulation of non-cartilage cell types by mechanically stimulated MSC secretome, thus providing valuable further insight into the pathology of joint destruction.

Results: Using a design of experiments (DoE) approach, we have established optimal loading conditions to a) increase TGFβ production and b) increase the mechanical activation of latent TGFβ protein. Interestingly the protocol optimal for expression is not the same as that optimal for activation. This suggests that rehabilitation protocols may need to increase in complexity to improve cellular differentiation.

Loading protocol	Shear frequency (Hz)	Compressive strain (%)
s-0-c-0	0	0
s-0_2-c-5	0.2	5
s-0_2-c-20	0.2	20
s-0_6-c-10	0.6	10
s-1-c-5	1	5
s-1-c-20	1	20

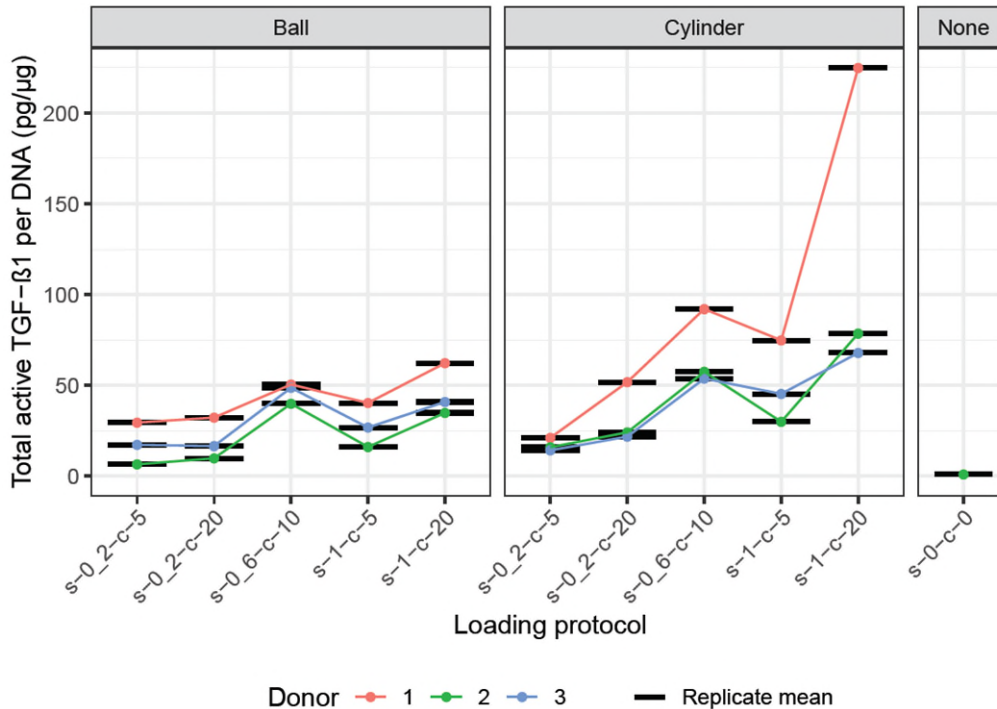
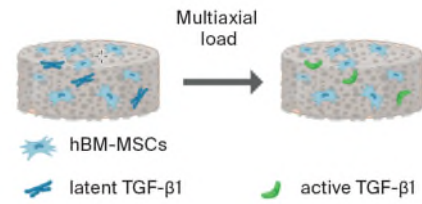

Figure 11.9.11: Overview of loading conditions applied to primary human MSCs embedded in a fibrin scaffold. Loading using ball or a cylinder was compared and active TGF β measured. TGF β activation was dependent on the loading protocol applied, with maximal activation obtained with the cylinder loading counterface.

Fund: Swiss National Funds (nr 31003A_179438 / 1), Funding: CHF 417'720, Period: 08/2018-07/2022

Partner:

- Snedeker Jess G (Prof, PhD), ETH Zürich, Switzerland

Antibiofilm therapy using Local Application of Bacteriophages (Antibio-LAB) (S Rottman, D Eglin, F Moriarty)

The Antibio-LAB project aims to develop and assess a local application mode for bacteriophage therapy of difficult to treat, antibiotic resistant orthopaedic device-associated infections. The Antibio-LAB project aims to optimise an injectable and degradable thermo-responsive hyaluronan formulation for the delivery of these phages directly to the site of infection. Within this initial project period, several tests regarding loading phages into the thermo-responsive HA-pNIPAM hydrogel were performed. The release profile, kinetics and storage conditions of phages in the hydrogel were analysed. Overall, the thermo-responsive HA-pNIPAM hydrogel seems to be suitable for ISP-phage embedding, while retaining its thermo-responsive properties. Release of phage for the gelled HA-pNIPAM samples can be observed for 21 days. Hydrogels with looser polymer networks (i.e. lower polymer concentration) do not show a faster release of phage load, indicating that the diffusion of ISP-phage from the hydrogel is minimally hindered by the polymer network at all tested concentrations.

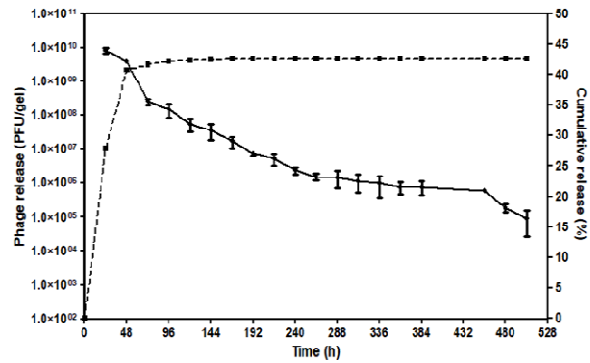
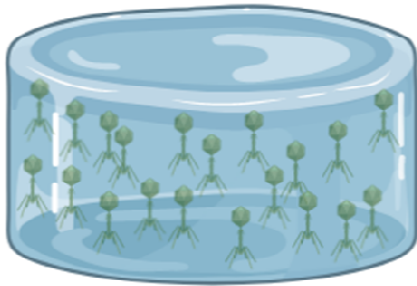

Figure 11.9.12: ISP-phage release from HA-pNIPAM hydrogels at 37°C. A total of 43% of the embedded phage were identified by plaque assay.

Pres:

Moriarty F, Rotman S. "Local Application of Bacteriophage in biofilm-associated orthopaedic infections". The Bacteriophage Networking Meeting, 14 December 2019, Zürich, Switzerland (oral)

Moriarty F. "Optimal delivery method". 38th Annual Meeting of the European Bone and Joint Infection Society, 12-14 September 2019, Antwerpen, Belgium (oral)

Partners:

- Lavigne R (MD), KU Leuven, Belgium
- Trampuz A (MD), Charité, Berlin, Germany

12 Team Members

Director

Richards R Geoff Prof, Prof, PhD, MSc 01.10.91

Vice Director

Alini Mauro Prof, PhD 01.07.99

ARI Management

Bentz Ulrich Dipl Ing HTL Mikrotechnik 01.08.07

Eglin David Prof, PhD 01.06.06

Grad Sibylle PD, Dr sc nat, PhD 03.08.00

Gueorguiev Boyko Prof, PhD, MSc (01.03.03 – 30.09.09) 01.07.10

Keller Rolf Technischer Kaufmann 17.06.96

Moriarty Fintan PhD, BSc 19.03.07

Stoddart Martin Prof, PhD (01.08.95– 30.09.96) 01.07.05

Wahl Sonia Dipl DH Ökonomin HFP 01.12.95

Zeiter Stephan Dr med vet, PhD (01.02.00 – 12.05.02) 01.06.03

Scientific & Technical Staff

Arens Daniel Dr med vet 01.11.07

Armiento Angela PhD 01.01.16

Badrutt Isabella Administrative Assistant 16.07.12

Bagnol Romain PhD student 01.10.19

Barblan Claudia Administrative Assistant (70%) 15.11.10

Barcik Jan PhD Candidate, MSc 01.04.17

Basoli Valentina PhD 01.04.17

Bluvol Mauro Chemielaborant (Eidg FA¹) 01.06.03

Brazerol Carmen Animal Care (Eidg FA¹) 01.03.18

Buchholz Tim med vet 01.04.19

Buschbaum Jan Dr rer med 01.08.15

Caspar Jan Poly mechanics 01.01.09

Ciriello Simona Journal Production Editor 12.09.16

Della Bella Elena PhD 01.01.18

D'Este Matteo PhD 01.04.11

Devantay Nicolas MSc (Nanosciences) 02.12.19

Di Luise Nunzia PhD 15.06.17

Erb Peter Animal Care (Eidg FA¹) 03.05.93

Ernst Manuela MSc, Human Movement Science 01.10.11

Escher Carla Administrative Assistant (40%) 01.01.95

Faoro Loris Animal Care 01.11.16

Faoro Pierina Arztgehilfin, Animal Care (Eidg FA¹) (70%) 01.12.07

Furlong-Jäggi Pamela Chemikerin FH, BSc (40%) 01.02.04

Furter Andrea Animal Care (Eidg FA¹) 24.04.06

Gehweiler Dominic Dr med 01.03.16

Goudsouzian Nora BSc 01.02.02

Hämmerl Nilo Practicant Animal Care 01.04.19

Hildebrand Maria MSc (Immunology) 01.01.18

Hofmann-Fliri Ladina MSc ETH 01.10.09

Hofstee Marloes PhD Candidate, MSc 20.11.17

Kamer Lukas Dr med, Dr med dent (80%) 21.05.07

Kasper Hermann Dipl Technician HF Systemtechnik 01.10.18

Keller-Stoddart Iris MTL Technician (60%) 21.10.09

Lackington William PhD 02.07.18

Ladner Yann PhD Candidate, MSc 01.08.18

Lanker Urban	Animal Care (Eidg FA ¹)	16.06.86
Li Zhen	Assistant Prof, PhD	01.08.11
Ma Junxuan	Dr med, PhD	02.03.17
Menzel Ursula	PhD, Dipl Biol	01.07.11
Mischler Dominic	Junior Project Leader (06.09.17 - 28.02.18)	01.10.18
Monaco Graziana	PhD Candidate, MSc	02.11.15
Müller Gregor	Lic phil, Librarian (50%)	17.01.05
Müller Reto	Animal Care (Eidg FA ¹)	13.11.01
Mys Karen	PhD	01.06.19
Nehrbass Dirk	Dr med vet, FTA Pathol + Toxicopathol	01.10.10
Noser Hansrudi	PD Dr ès science EPFL	18.10.04
Peroglio Marianna	PhD	01.03.09
Perren Dominic	Animal Care	01.02.83
Peter Robert	Dipl Laborant HFP	15.09.84
Post Virginia	PhD (60%)	20.09.10
Rotman Stijn	PhD Candidate, MSc	26.08.16
Schneider Monika	Administrative Assistant (60%)	06.02.06
Schwab Andrea	PhD	01.04.18
Schwyn Ronald	Dipl Medizintechniker HF	01.11.92
Serra Tiziano	PhD	01.10.16
Siverino Claudia	PhD	01.11.19
Soubrier Astrid	PhD	05.08.19
Spiller Flurin	Apprentice / Poly mechanics	01.08.15
Sprecher Christoph	PhD, Dipl Ing FH	01.02.00
Steiner Sandra	PhD	01.01.14
Stenger Valentina	med vet	01.01.19
Sumrall Eric	PhD	01.10.19
Thompson Keith	PhD, BSc (Hons), MSc,	26.05.15
Vainieri Letizia	PhD Candidate, MSc	01.09.15
Varga Peter	PhD	04.08.14
Varjas Viktor	MSc, Software Engineer	01.01.14
Vernengo Andrea	PhD	01.09.19
Verrier Sophie	Dr sces sc nat	01.08.04
Vivalda Marisa	Administrative Assistant	01.05.03
Wahl Dieter	Dipl techn Werkzeugspezialist HFP	01.11.93
Wallimann Alexandra	PhD Candidate, MSc	01.02.18
Windolf Markus	Dr biol hum Dipl Ing	01.11.04
Zderic Ivan	MSc ETH	01.02.11
Ziadlou Reihane	PhD Candidate, MSc	01.11.15
Zweifel Erich	European Industrial Engineer EIE	30.11.92

¹ Eidg FA = Eidg Fähigkeitsausweis

Apprentice

Bärtschi Cecilia	Apprentice	01.08.18
------------------	------------	----------

Medical Research Fellows

Ahmad Paras	Research Fellow (Pakistan)	01.10.19
Buchholz Tim	VET Research Fellow (Germany)	16.04.18 – 29.03.19
Burch Marc-Antoine	Research Fellow (Switzerland)	07.01.19 – 20.12.19
Constant Caroline	VET Research Fellow (Canada)	04.03.19 – 20.12.19
Cui Shangbin	Research Fellow (China)	07.01.19
Dauwe Jan	Research Fellow (Belgium)	01.08.19

Foster Andrew	Research Fellow (Australia)	07.02.19 – 27.09.19
Gomez Sierra Maria Antonia	Research Fellow (Columbia)	04.02.19
Handrich Kristin	Research Fellow (Germany)	04.03.19 – 30.11.19
Ivanov Stoyan	Research Fellow (Bulgaria)	30.09.19 – 20.12.19
Kamali Seyed Amir	Research Fellow (Iran)	01.07.19
Keshishian Aron	Research Fellow (Germany)	01.04.19 – 31.12.19
Lodde Moritz	Research Fellow (Germany)	01.07.19 – 31.12.19
Milstrey Alexander	Research Fellow (Germany)	23.07.18 – 25.01.19
Muthukrishnan Gowrishankar	Research Fellow Guest (India)	01.07.19 – 30.09.19
Onsea Jolien	Research Fellow (Belgium)	01.06.19 – 30.09.19
Panagiotopoulou Vasiliki	Research Fellow (Greece)	03.09.18 – 30.08.19
Pugliese Brenna	VET Research Fellow (USA)	01.07.19
Sanchez Rosenberg Guillermo	Research Fellow (Guatemala)	30.06.19
Schader Jana	Research Fellow (Germany)	01.07.19
Schopper Clemens	Research Fellow (Austria)	03.01.19 – 20.12.19
Stefanov Aleksandar	Research Fellow (Bulgaria)	30.09.19
Terjajevs Igars	Research Fellow (Latvia)	01.09.19 – 20.12.19
Tourbier Céline	Research Fellow Guest (Germany)	19.02.19
Weisemann Ferdinand	Research Fellow (Germany)	01.09.19 – 20.12.19
Westbrock Frederik	Research Fellow Guest (Germany)	15.10.18 – 31.07.19
Wittmann Charlotte	VET Research Fellow (Germany)	03.01.19
Xu Yichi	Research Fellow (China)	29.03.18 – 12.03.19

Internships

Burkhard Benjamin	Internship (Switzerland)	22.10.18 – 30.06.19
Casty Lino	Internship (Switzerland)	07.01.19 – 15.02.19
Danker Carolin	Internship (Germany)	01.11.19
Di Marzio Nicola	Internship (Italy)	01.05.19 – 31.12.19
Füllemann Priscilla	Internship (Germany)	01.11.19
Hatt Phelipe	Internship (Germany / Brazil)	11.02.19 – 20.12.19
Jörger Philippa	Internship ETH (Switzerland)	01.10.18 – 01.02.19
Jucker Tino	Internship ETH (Switzerland)	01.08.18 – 08.02.19
Keck Katharina	Internship (Germany)	01.07.19 – 30.09.19
Kluser Nadine	Internship (Switzerland)	01.09.19
Li Wenyue	Internship (China)	03.06.19 – 30.08.19
Pellicciotta Daniele	Internship (Italy)	23.04.18 – 29.03.19
Stefanoska Despina	Internship (The Netherlands)	12.04.18 – 15.04.19
Van der Heide Daphne	Internship (The Netherlands)	05.08.19 – 30.11.19
Wapp Christina	Internship (Switzerland)	01.10.18 – 31.03.19
Yamamoto Taiyo	Internship (Switzerland)	07.10.19

VET Practica

Krejczinger Nora	VET Practica	01.07.19 – 30.09.19
Matvejeva Marija	VET Practica	07.01.19 – 01.03.19
Michault Marine	VET Practica	01.01.19 – 31.01.19
Tapia James-Dean	VET Practica	21.09.19 – 20.12.19

Visiting Professor

Vernengo Andrea	Regenerative Orthopaedics (D Eglin) Rowan University, Glassboro, NJ, USA (Guest self-funded sabbatical)	01.07.18 – 31.08.19
-----------------	---	---------------------

Guest Scientists / Students

Acosta Melanie	Internship (Germany) University Furtwangen, Villingen, Germany	01.09.19
Al Saify Ivan	Guest Internship (The Netherlands) Fontys University, Eindhoven (The Netherlands)	03.09.18 – 31.01.19
Alexeev Dmitriy	Guest PhD Candidate ETH Zürich	01.01.19 – 20.02.19
Aygün Talita	Internship (Germany) University Furtwangen, Villingen, Germany	01.09.19
Chang Josh	Guest Vet Student (USA) Western University, College of Veterinary Medicine, California	21.05.19 – 19.07.19
Ciric Daniel	Internship (Australia) Flinders University, Tonesly, Australia	01.09.18 – 29.03.19
Comtesse Simon	Internship (Switzerland) ETH Zürich	01.03.19 – 30.08.19
Guo Wei	Guest Student (China) Hospital of Sun Yat-sen University Zhongshan, China University of Berlin, Germany	01.01.18 – 20.12.19
Häne Surya	Internship (Switzerland) ETH Zürich	08.07.19
Hasler Johannes	Internship (Switzerland) ETH Zürich	01.09.19 – 30.11.19
Kieran Joyce	Guest Student (Ireland) National University of Ireland, Galway	04.03.19 – 31.03.19
Kirchhoff Konstantin	Guest Student (Germany) University of Munich, Germany	25.02.19 – 01.03.19
Mys Karen	Guest Student (Belgium) KU Leuven, Belgium	12.03.18 – 15.02.19
Nan Jiang	Guest Scientist (China) Sichuan University	01.04.19
Pfannkuche Judith-Johanna	Guest Scientist (Germany) Funded by German 3R Foundation (SET) with Dr Gernot Lang from Freiburg University	01.11.18 – 23.12.19
Wesdorp Tim	Guest PhD Student (The Netherlands) Erasmus University Rotterdam	11.10.19
Osterhoff Georg, Pari Carlotta, Babu S.	Guests, Perren Fellowship 2019	20.05.19 – 31.05.19
Valsamis Markos, Sitnik Alesandre	Guests, Perren Fellowship 2019	16.09.19 – 27.09.19

Employees left 2019

Boot Willemijn	PhD	01.03.17 – 30.06.19
Eberli Ursula	MSc ETH	01.02.11 – 30.09.19
Linardi Flavio	Laborant Fachrichtung Chemie (Eidg FA ¹)	01.08.15 – 30.09.19
Stanic Barbara	PhD	01.06.14 – 31.05.19
Semere Yemane	Apprentice	01.06.15 – 31.07.19
Wangler Sebastian	PhD	01.02.17 – 31.01.19

¹ Eidg FA = Eidg Fähigkeitsausweis

Guests

Acklin Yves	Biomedical Development, 04.03.2019 Kantonsspital Baselland, Project Collaboration
Alexeev Dmitriy	Musculoskeletal Regeneration, 24. – 28.06.2019 ETH Zürich, Project Collaboration
Arand Charlotte	Biomedical Development, 28. – 29.01. & 08. – 09.04.2019 University Mainz, Project Collaboration
Biondani Enrico	Musculoskeletal Regeneration, 29.04. – 10.05.2019 University of Trento, Collaboration Master Thesis Project
Christoffel Ladina	Biomedical Development, 17.05.2019 IGE Bern, Patentrechte Recherche
Cheikh-Sarraf Bijan	Biomedical Development Group, 20.05.2019 Kantonsspital Baselland, Lab Demo
Giger Christian	Biomedical Development, 20.05.2019 Rücken- & Schmerz-Praxis, Gümligen / Lab Demo
Guarch Pérez Clara M.	Musculoskeletal Infection (F Moriarty), 24. – 25.06.2019 UMC Amsterdam, Visit ARI & eCM conference
Handrich Kristin	Biomedical Development, 28. – 29.01.2019 University Mainz, Project Collaboration
Helfen Tobias	Biomedical Development, 28. – 29.01.2019 LMU München, Project Partner
Hofbauer Lisa Maria	Biomedical Development, 20. – 21.05.2019 LMU München, Project Partner
Kasper Lena	Biomedical Development (I Zderic), 06.03. – 31.03.2019 Uniklinik Jena, Germany, Project Collaboration
Ledroit Diane	Musculoskeletal Regeneration (S Grad), 25.02–26.02. / 31.07.2019 CSEM, Neuchâtel, Project Collaboration
Lenz Mark	Biomedical Development (I Zderic), 04.03. – 31.03.2019 Uniklinik Jena, Germany, Project Collaboration

Malouchev Orlin	Biomedical Development, 25. – 26.04.2019 Participation ETH Zurich Kurs
Marangoni Marta	Musculoskeletal Regeneration (E Della Bella), 04.03 – 09.03.2019 Liceo Lugano 2, High School thesis
Menze Johanna	Biomedical Development (I Zderic), 13.02.2019 DePuy Synthes, Project Collaboration
Morgenstern Mario	Musculoskeletal Infection, 24. – 25.01.2019 Collaboration Project
Oliveros Ruben	Biomedical Development (D Mischler), 30.09. – 04.10.2019 ETH Zürich, Collaboration
Petta Dalila	Musculoskeletal Regeneration (T Serra), 14.01.2019
Raders Paul	Biomedical Development (J Buschbaum), 17.05.2019 Medical Center, St. Moritz
Rehli Melanie	Biomedical Development, 20.05.2019 Mainstay Medical, Lab Demonstration
Riool Martijn	Musculoskeletal Infection (F Moriarty), 24.06. – 25.06.2019 UMC Amsterdam, Visit ARI & eCM conference
Saura-Sanchez Eladio	Biomedical Development (B Gueorguiev), 08.02.2019 University Hospital of Elche, Spain
Schneider Kerstin	Biomedical Development, 05.03. – 06.03.2019 Schulthess Clinic Zürich, Project Collaboration
Shiroft Jason	Biomedical Development (D Wahl), 20.05.2019 Mainstay Medical, Dublin, Lab Demo
Utomo Lizette	Musculoskeletal Regeneration (A Armiento), 08.07. – 23.07.2019 University Utrecht, Project Collaboration
Weber André	Biomedical Development, 04.04.2019 DPS Trauma, Zuchwil, Collaboration Project
Peeters Günther, De Swedt, Walsh, Shiroft, Tamilmani	Biomedical Development, 20.05.2019 Mainstay Medical, Dublin, Ireland, Lab Demo
Wyss Karin, Stöckli Philipp, Rehli Melanie, Huibuur Dietrich	Biomedical Development, 20.05.2019 Lab Demonstration

Guest Presentations at AO Center

Feb 08, 2019 Prof Ron June from Mechanical & Industrial Engineering, Montana State University, Bozeman, MT, USA gave a guest presentation with the title: Toward Improved Clinical Care for Osteoarthritis: from Basic Cartilage Biology to Biomarkers.

Feb 26, 2019 Dr Marc Bohner from RMS Foundation, Bettlach, Switzerland gave a guest presentation with the title: A proposed mechanism for material-induced heterotopic ossification.

March 05, 2019 Dr Lizette Utomo from Oral and Maxillofacial Surgery and Special Dental Care, University Medical Center, Utrecht, the Netherlands gave a guest presentation with the title: MACRON – Mandibular Condyle RegeneratiON

March 08, 2019 Dr Fabio Galbusera from Laboratory of Biological Structures Mechanics (LABS), IRCCS Istituto Ortopedico Galeazzi, Milan, Italy gave a guest presentation with the title: Biomechanics of spinal deformities innovations from musculoskeletal modelling and artificial intelligence.

March 26, 2019 Dr Wuwei Ren from ETH Zurich, Switzerland gave a guest presentation with the title: KaleiBox: a portable device for multifunctional fluorescence.

May 24, 2019 Prof Dr Jess Gerrit Snedeker from Institute for Biomechanics, ETH Zurich, Switzerland gave a guest presentation with the title: Cell activation by matrix damage: the tendon mechanostat.

July 12, 2019 Eric Sumrall from Food Microbiology, Dept. of Health Sciences and Technology, ETH Zurich, Switzerland gave a guest presentation with the title: Bacteriophage predation selects for attenuated virulence in *Listeria monocytogenes*.

Aug 05, 2019 Dr Jacek Wychowaniec from School of Chemistry, University College Dublin, Ireland gave a guest presentation with the title: 3D Printing of Spatially Patterned Magnetically Responsive Hydrogels.

Aug 12, 2019 Dr Giulia Morgese from Eindhoven University of Technology, Eindhoven, the Netherlands gave a guest presentation with the title: Exploring covalent and supramolecular polymers for 2D and 3D biomaterials.

Sept 10, 2019 Dr Mohy Taha from Shoulder and Elbow Surgery, Basel University Hospital, Basel, Switzerland gave a guest presentation with the title: MY-FELLOWSHIP for fellowship providers.

Sept 26, 2019 Claudia Siverino from Department of Tissue Engineering and Regenerative Medicine, University of Würzburg, Germany gave a guest presentation with the title: Induction of ectopic bone formation by site directed immobilized BMP2 variants in vivo.

Oct 22, 2019 Dr Markus Rottmar from EMPA St. Gallen, Switzerland gave a guest presentation with the title: Cell at Surfaces Group Activities at EMPA.

Oct 22, 2019 Fabian Iteel from EMPA St. Gallen, Switzerland gave a guest presentation with the title: Artificial bone cells within electrospun fiber scaffold.

Oct 22, 2019 Géraldine Guex from EMPA St. Gallen, Switzerland gave a guest presentation with the title: Novel approaches to treat skin wounds.

Nov 19, 2019 Maryam Asadi Korayem from ETH Zurich, Switzerland gave a guest presentation with the title: Injectable hydrogel based on sulfated hyaluronic acid for cartilage regeneration.

13 ARI Patents

Cannula

- First Application: PCT/CH2008/000238 filed 2008-05-27
- Case: 10.2283
- Developer / Inventors: AOR&D, A Gisep, V Boner, N Suhm

Cannula and Device for Liquid Jet Irrigation of Bone

- First Application: PCT/CH2008/000019 filed 2008-01-15
- Case: 10.2356
- Developer / Inventors: AOR&D, A Gisep, P Kuhn

Bone Fixation Device with Cover

- First Application: PCT/CH2009/000095 filed 2009-03-18
- Case: 10.2406
- Developer / Inventors: AOR&D, RG Richards, C Nötzli

Bone Fixation Device

- First Application: PCT/CH2008/000349 filed 2008-08-15
- Case: 10.2470
- Developer / Inventor: ARI, M Windolf

Device for Processing and Transmitting Measured Signals for Monitoring and/or Controlling Medical Implants, Diagnostic Devices or Biological Processes

- First Application: PCT/CH2009/000198 filed 2009-06-11
- Case: 10.2555
- Developer / Inventor: ARI, M Windolf

Cannula and Kit for Bone Cement Injection

- First Application: PCT/CH2011/000007 filed 2011-04-19
- Case: 10.2567
- Developer / Inventor: ARI, M Windolf

Method for Designing and/or Optimizing a Surgical Device

- First Application: PCT/CH2010/000046 filed 2010-02-25
- Case: 10.2607
- Developer / Inventors: AOR&D, S Brianza, D Schuima, A Tami

Surgical Instrument

- First Application: PCT/CH2010/000330 filed 2010-12-24
- Case: 10.2676
- Developer / Inventors: AOR&D, S Brianza, R Schwyn

Identification and Selection of Functionally Committed Mesenchymal Stem Cells Subpopulations

- First Application: PCT/CH2006/000425 filed 2006-08-11
- Case: 22.2277
- Developer / Inventors: ARI, M Alini, M Stoddart

Method and Device for Measuring the Local Mechanical Resistance of a Porous Body

- First Application: PCT/CH2006/000611 filed 2006-10-31
- Case: 10.2281
- Developer / Inventors: AOR&D, R Schwyn, M Hänni, N Suhm

Thermosensitive Hyaluronic Acid Conjugates and Methods for the Preparation thereof

- First Application: IP 5003 PCT E filed 2013-10-02
- Case: 10.F5003
- Developer / Inventors: AOR&D, M D'Este, D Eglin

Method for manufacturing an auxiliary device suitable for the manufacture of a patient customized implant

- First Application: PCT/CH2015/000001 filed 2015-01-13
- Case: 10.3180
- Developer / Inventors: L Kamer, D Eglin

Kit for assembling a medical device provided with data acquisition means

- First Application: PCT/CH2015/000062 filed 2015-04-29
- Case: 10.3211
- Developer / Inventors: M Windolf

Bone plate

- First Application: PCT/ CH2015/000117 filed 2015-08-07
- Case: 10.3302
- Developer / Inventors: M Windolf, D Epari, M Schütz, T Pohlemann, C Nötzli

Bone Implant for Correcting Unbalanced Growth Plate Activity

- First Application: CH2016/01338 filed 2016-10-06
- Case: 10.3487
- Developer / Inventors: M Windolf, M Schütz

Surface Acoustic Wave (SAW) 3D Printing Method

- First Application: CH01058/17 filed 2017-08-25
- Case: 10.F5004
- Developer / Inventors: T Serra, D Eglin, M Alini

Device and Method for Real-Time Tracking, Navigation and Manipulation of Bone Fragment, Surgical Instruments, Tools or Implants in Computer-Assisted Surgery ("X-in-1 GO")

- First Application: CH00145/18 filed 2018-02-07
- Case: 10.3567
- Developer / Inventor: J Buschbaum, M Windolf

Method of determining or influencing the chondrogenic potential of mesenchymal stromal cells (Receptor Profile)

- First Application: EP19184241.8 filed 2019-07-03
- Case: F5969
- Developer / Inventors: M Stoddart, M Alini

Patterning device for the preparation of three-dimensional structures (3D SIM Device)

- First Application: EP20190203370 filed 2019-10-15
- Case: BFHTI-4-EP
- Developer / Inventors: T Serra, M Thurner

Device for measuring, processing and transmitting implant parameters (Fracture Monitor III)

- First Application: CH01335/19 filed 2019-10-22
- Case: 10.3988
- Developer / Inventors: M Windolf

Biphasic Plate (Biphasic Plate II)

- First Application: CH 01515/19 filed 2019-11-29
- Case: 10.4024
- Developer / Inventors: M Windolf, D Epari

None-stick antibiotics gels

- First Application: CH 01628/19 filed 2019-12-16
- Case: F6183
- Developer / Inventors: M D'Este

14 Publications & Presentations

14.1 2014-2019 Six-year ARI Key Performance Indicators

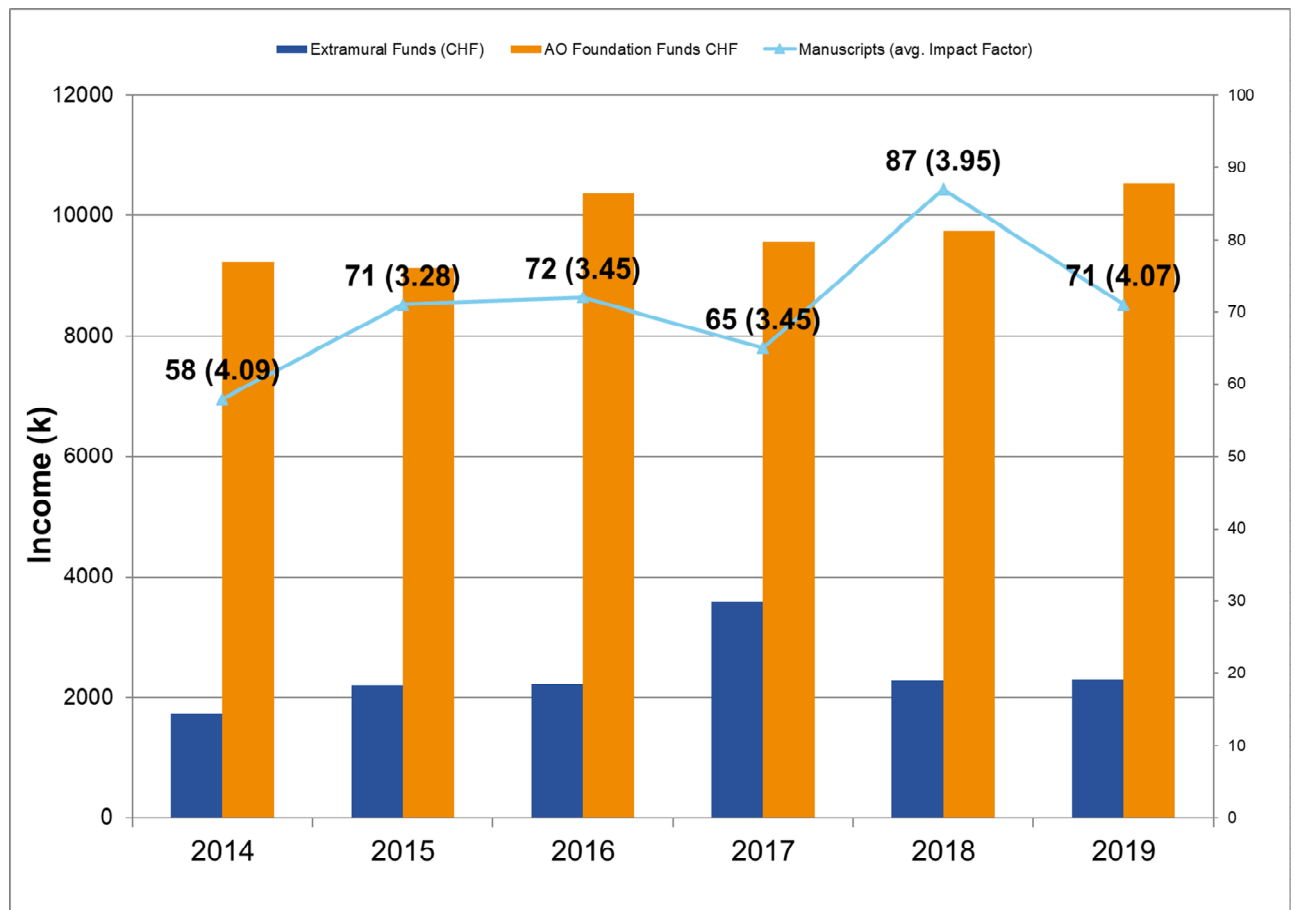

14.2 2019 Published peer reviewed papers (epub & in print)

Ahrend M-D, Noser H, Shanmugam R, Burr F, Kamer L, Zaman TK, Hügli H, Nagy A, Richards RG, Gueorguiev-Rüegg B. Development of generic Asian pelvic bone models using CT-based 3D statistical modelling. *J Orthop Translat*. 2019;epub Nov 4

Armiento AR, Alini M, Stoddart MJ. Articular fibrocartilage - Why does hyaline cartilage fail to repair? *Adv Drug Deliv Rev*. 2019;146:289-305

Augurio A, Cortelletti P, Tognato R, Rios A, Levato R, Malda J, Alini M, Eglin D, Giancane G, Speghini A, Serra T. A Multifunctional Nanocomposite Hydrogel for Endoscopic Tracking and Manipulation. *Advanced Intelligent Systems*. 2019;epub Dec 03

Bäumlein M, Hanke A, Gueorguiev B, Nerlich M, Lioudakis E, Perren T, Rillmann P, Ryf C, Loibl M. Long-term outcome after surgical treatment of intra-articular tibial plateau fractures in skiers. *Arch Orthop Trauma Surg*. 2019;139(7):951-959

Bläsius FM, Link BC, Beeres FJP, Iselin LD, Leu BM, Gueorguiev B, Klos K, Ganse B, Nebelung S, Modabber A, Eschbach D, Weber CD, Horst K, Knobe M. Impact of surgical procedures on soft tissue microcirculation in calcaneal fractures: A prospective longitudinal cohort study. *Injury*. 2019;50(12):2332-2338

Busscher HJ, Alt V, van der Mei HC, Fagette PH, Zimmerli W, Moriarty TF, Parvizi J, Schmidmaier G, Raschke MJ, Gehrke T, Bayston R, Baddour LM, Winterton LC, Darouiche RO, Grainger DW. A Trans-Atlantic Perspective on Stagnation in Clinical Translation of Antimicrobial Strategies for the Control of Biomaterial-Implant-Associated Infection. *ACS Biomater Sci Eng*. 2019;5(2):402-6

Cao HJ, Li CR, Wang LY, Ziadlou R, Grad S, Zhang Y, Cheng Y, Lai YX, Yao XS, Alini M, Qin L, Wang XL. Effect and mechanism of psoralidin on promoting osteogenesis and inhibiting adipogenesis. *Phytomedicine*. 2019;61:152860

Ciric D, Mischler D, Qawasmi F, Wenzel L, Richards RG, Gueorguiev B, Windolf M, Varga P. Secondary Perforation Risk in Plate Osteosynthesis of Unstable Proximal Humerus Fractures: A Biomechanical Investigation of the Effect of Screw Length. *J Orthop Res*. 2019;37(12):2625-2633

Davidson MD, Ban E, Schoonen ACM, Lee M-H, D'Este M, Shenoy VB, Burdick JA. Mechanochemical Adhesion and Plasticity in Multifiber Hydrogel Networks. *Advanced Materials*. 2019;epub Dec 18():e:1905719

Della Bella E, Stoddart MJ. Cell detachment rapidly induces changes in noncoding RNA expression in human mesenchymal stromal cells. *BioTechniques*. 2019;67(6):286-93

Deml MC, Benneker LM, Schmid T, Sakai D, Albers CE, Hoppe S, Zeiter S. Ventral Surgical Approach for an Intervertebral Disc Degeneration and Regeneration Model in Sheep Cervical Spine: Anatomic Technical Description, Strengths and Limitations. *Vet Comp Orthop Traumatol*. 2019;32

Depypere M, Morgenstern M, Kuehl R, Senneville E, Moriarty TF, Obremskey WT, Zimmerli W, Trampuz A, Lagrou K, Metsemakers WJ. Pathogenesis and management of fracture-related infection. *Clin Microbiol Infect*. 2019; epub Aug 22

Fahy N, Menzel U, Alini M, Stoddart MJ. Shear and Dynamic Compression Modulates the Inflammatory Phenotype of Human Monocytes *in vitro*. *Front Immunol*. 2019;10(383)

Fletcher JWA, Windolf M, Richards RG, Gueorguiev B, Buschbaum J, Varga P. The importance of locking plate positioning in proximal humeral fractures as predicted by computer simulations. *J Orthop Res*. 2019;37(4):957-964

Fletcher JWA, Windolf M, Grünwald L, Richards RG, Gueorguiev B, Varga P. The influence of screw length on predicted cut-out failures for proximal humeral fracture fixations predicted by finite element simulations. *Arch Orthop Trauma Surg*. 2019;139:1069-1074

- Fletcher JWA, Windolf M, Richards RG, Gueorguiev B, Varga P. Screw configuration in proximal humerus plating has a significant impact on fixation failure risk predicted by finite element models. *J Shoulder Elbow Surg.* 2019;28(9):1816-1823
- Frauchiger DA, Tekari A, May RD, Džrafo E, Chan SC, Stoyanov J, Bertolo A, Zhang X, Guerrero J, Sakai D, Schol J, Grad S, Tryfonidou MA, Benneker LM, Gantenbein B. FACS is more potent to fish IVD progenitor cells than magnetic and bead-based methods. *Tissue Eng Part C Methods.* 2019;25(10):571-580
- Ganse B, Böhle F, Pastor T, Gueorguiev B, Altgassen S, Gradl G, Kim B-S, Modabber A, Nebelung S, Hildebrand F, Knobe M. Microcirculation After Trochanteric Femur Fractures: A Prospective Cohort Study Using Non-invasive Laser-Doppler Spectrophotometry. *Front Physiol.* 2019;10(236)
- Gentile P, Alarcon EI, Alini M. Editorial: Functionalization at Nanoscale to Enhance Specific Biological Activities. *Front Bioeng Biotechnol.* 2019;7:178
- Gieling F, Peters S, Erichsen C, Richards RG, Zeiter S, Moriarty TF. Bacterial osteomyelitis in veterinary orthopaedics: Pathophysiology, clinical presentation and advances in treatment across multiple species. *Vet J* 2019;250:44-54
- Gröngröft I, Wissing S, Meesters DM, Poeze M, Matthys-Mark R, Ito K, Zeiter S. Development of a novel murine delayed secondary fracture healing *in vivo* model using periosteal cauterization. *Arch Orthop Trauma Surg.* 2019;139(12):1743-1753
- Guillaume O, Schmid T, Kluge K, Weber FE, Richards RG, Eberli U, Eglin D, Zeiter S. Introduction of the Anspach drill as a novel surgical drill for creating calvarial defects in animal models. *J Orthop Res.* 2019;37(5):1183-1191
- Häckel S, Zolfaghar M, Du J, Hoppe S, Benneker LM, Garstka N, Peroglio M, Alini M, Grad S, Yayon A, Li Z. Fibrin-Hyaluronic Acid Hydrogel (RegenoGel) with Fibroblast Growth Factor-18 for *In Vitro* 3D Culture of Human and Bovine Nucleus Pulposus Cells. *Int J Mol Sci.* 2019;20(20):5036
- Hagen JE, Rausch S, Simons P, Richards RG, Lenz M, Knobe M, Gueorguiev B, Klos K. Computed Tomography Analysis for Quantification of Displacement of the Distal Fibula in Different Foot Positions with Weightbearing and Sequentially Increased Instability: An Anatomic Cadaveric Study on Syndesmosis. *J Foot Ankle Surg.* 2019;58(4):734-8
- Hatt LP, Thompson K, Müller WEG, Stoddart MJ, Armiento AR. Calcium Polyphosphate Nanoparticles Act as an Effective Inorganic Phosphate Source during Osteogenic Differentiation of Human Mesenchymal Stem Cells. *Int J Mol Sci.* 2019;20(22):E5801
- Herrmann M, Hildebrand M, Menzel U, Fahy N, Alini M, Lang S, Benneker L, Verrier S, Stoddart MJ, Bara JJ. Phenotypic Characterization of Bone Marrow Mononuclear Cells and Derived Stromal Cell Populations from Human Iliac Crest, Vertebral Body and Femoral Head. *Int J Mol Sci.* 2019;20(14):E3454
- Herrmann M, Stanic B, Hildebrand M, Alini M, Verrier S. *In vitro* simulation of the early proinflammatory phase in fracture healing reveals strong immunomodulatory effects of CD146-positive mesenchymal stromal cells. *J Tissue Eng Regen Med.* 2019;13(8):1466-1481
- Ihle C, Maurer J, Ziegler P, Stöckle U, Ateschrang A, Ahrend MD, Schröter S. Sporting activity is reduced following medial reefing performed for patellar dislocation: A retrospective case series of 144 patients with a minimum follow-up of 24 months. *BMC Musculoskelet Disord.* 2019;20(1):34
- Johnstone B, Stoddart MJ, Im GI. Multi-Disciplinary Approaches for Cell-Based Cartilage Regeneration. *J Orthop Res.* 2019;epub Sep 3
- Klüter T, Hassan R, Rasch A, Naujokat H, Wang F, Behrendt P, Lippross S, Gerdesmeyer L, Eglin D, Seekamp A, Fuchs S. An *ex vivo* bone defect model to evaluate bone substitutes and associated bone regeneration processes. *Tissue Eng Part C Methods.* 2019;epub Dec 5

Koivisto K, Karppinen J, Haapea M, Järvinen J, Kyllönen E, Tervonen O, Niinimäki J, Alini M, Lotz J, Dudli S, Samartzis D, Risteli J, Majuri M-L, Alenius H, Grad S. The Effect of Zoledronic Acid on Serum Biomarkers among Patients with Chronic Low Back Pain and Modic Changes in Lumbar Magnetic Resonance Imaging. *Diagnostics*. 2019;9(4):212

Kovermann NJ, Basoli V, Della Bella E, Alini M, Lischer C, Schmal H, Kubosch EJ, Stoddart MJ. BMP2 and TGF-beta Cooperate Differently during Synovial-Derived Stem-Cell Chondrogenesis in a Dexamethasone-Dependent Manner. *Cells*. 2019;8(6):E636

Kurutz M, Varga P, Jakab G. Prophylactic vertebroplasty versus kyphoplasty in osteoporosis: A comprehensive biomechanical matched-pair study by *in vitro* compressive testing. *Med Eng Phys*. 2019;65:46-56

Lai Y, Li Y, Cao H, Long J, Wang X, Li L, Li C, Jia Q, Teng B, Tang T, Peng J, Eglin D, Alini M, Grijpma DW, Richards RG, Qin L. Osteogenic magnesium incorporated into PLGA/TCP porous scaffold by 3D printing for repairing challenging bone defect. *Biomaterials*. 2019;197:207-19

Loepfe M, Duss A, Zafeiropoulou KA, Bjorgvinsdottir O, D'Este M, Eglin D, Fortunato G, Klasen J, Ferguson SJ, Wuertz-Kozak K, Krupkova O. Electro spray-Based Microencapsulation of Epigallocatechin 3-Gallate for Local Delivery into the Intervertebral Disc. *Pharmaceutics*. 2019;11(9):e435

Lolli A, Sivasubramaniyan K, Vainieri ML, Oieni J, Kops N, Yayon A, van Osch G. Hydrogel-based delivery of antimicroR-221 enhances cartilage regeneration by endogenous cells. *J Control Release*. 2019;309:220-30

Long RG, Ferguson SJ, Benneker LM, Sakai D, Li Z, Pandit A, Grijpma DW, Eglin D, Zeiter S, Schmid T, Eberli U, Nehrbass D, Di Pauli von Treuheim T, Alini M, Iatridis JC, Grad S. Morphological and biomechanical effects of annulus fibrosus injury and repair in an ovine cervical model. *JOR SPINE*. 2019; epub Dec 21

Makelov B, Gueorguiev B, Apivatthakakul T. Definitive external plate stabilization with metaphyseal locking plate LISS-DF in multiple trauma patient with "floating knee" injury. A case report. *Ortopediâ i travmatologiâ / Bul J Ortop Trauma*. 2019;56(1):12-19

Makelov B, Silva JD, Apivatthakakul T, Gueorguiev B, Varga P. Externalized locked plating of unstable high energy proximal tibial fractures. A fea study. *Ortopediâ i travmatologiâ / Bul J Ortop Trauma* 2019;56(3):124-38

Metsemakers WJ, Fragomen AT, Moriarty TF, Morgenstern M, Egol KA, Zalavras C, Obrebsky WT, Raschke M, McNally MA. Evidence-based recommendations for Local antimicrobial strategies and Dead space management in Fracture-Related Infection. *J Orthop Trauma*. 2019; epub Aug 26

Metsemakers WJ, Morgenstern M, Senneville E, Borens O, Govaert GAM, Onsea J, Depypere M, Richards RG, Trampuz A, Verhofstad MHJ, Kates SL, Raschke M, McNally MA, Obrebsky WT, Fracture-Related Infection Group. General treatment principles for fracture-related infection: recommendations from an international expert group. *Arch Orthop Trauma Surg*. 2019; epub Oct 29

Moriarty TF, Harris LG, Mooney RA, Wenke JC, Riool M, Zaat SAJ, Moter A, Schaer TP, Khanna N, Kuehl R, Alt V, Montali A, Liu J, Zeiter S, Busscher HJ, Grainger DW, Richards RG. Recommendations for design and conduct of preclinical *in vivo* studies of orthopedic device-related infection. *J Orthop Res*. 2019;37(2):271-87

Mys K, Varga P, Gueorguiev B, Hemmatian H, Stockmans F, van Lenthe GH. Correlation Between Cone-Beam Computed Tomography and High-Resolution Peripheral Computed Tomography for Assessment of Wrist Bone Microstructure. *J Bone Miner Res*. 2019;34(5):867-874

Mys K, Varga P, Gueorguiev B, Hemmatian H, Stockmans F, van Lenthe GH. Reply Letter to the Editor: Clinical in Vivo Assessment of Bone Microarchitecture With CT Scanners: An Enduring Challenge. *J Bone Miner Res*. 2019;epub Dec 5

Nasiri N, Hosseini S, Alini M, Khademhosseini A, Eslaminejad MB. Targeted Cell Delivery for Articular Cartilage Regeneration and Osteoarthritis Treatment. *Drug Discov Today*. 2019;24(11):2212-2224

Nowicki B, Nehrbass D, Arens D, Stadelmann VA, Zeiter S, Otto S, Kircher P, Stoddart MJ. Medication-related osteonecrosis of the jaw in a minipig model: Parameters for developing a macroscopic, radiological, and microscopic grading scheme. *J Craniomaxillofac Surg*. 2019;47(7):1162-1169

Panagiotopoulou VC, Varga P, Richards RG, Gueorguiev B, Giannoudis PV. Late screw-related complications in locking plating of proximal humerus fractures: A systematic review. *Injury*. 2019;50(12):2176-2195

Pérez-Köhler B, Linardi F, Pascual G, Bellon JM, Eglin D, Guillaume O. Efficacy of antimicrobial agents delivered to hernia meshes using an adaptable thermo-responsive hyaluronic acid-based coating. *Hernia*. 2019;epub Nov 28

Pfannkuche JJ, Guo W, Cui S, Ma J, Lang G, Peroglio M, Richards RG, Alini M, Grad S, Li Z. Intervertebral disc organ culture for the investigation of disc pathology and regeneration - benefits, limitations, and future directions of bioreactors. *Connect Tissue Res*. 2019;epub Sep 26

Puetzler J, Zalavras C, Moriarty TF, Verhofstad MHJ, Kates SL, Raschke MJ, Rosslenbroich S, Metsemakers WJ. Clinical practice in prevention of fracture-related infection: An international survey among 1197 orthopaedic trauma surgeons. *Injury*. 2019;50(6):1208-1215

Puetzler J, Milstrey A, Everding J, Raschke M, Arens D, Zeiter S, Richards RG, Moriarty TF. Focused high-energy extracorporeal shockwaves as supplemental treatment in a rabbit model of fracture related infection. *J Orthop Res*. 2019;epub Dec 11

Safari F, Fani N, Eglin D, Alini M, Stoddart MJ, Eslaminejad MB. Human Umbilical Cord-derived Scaffolds for Cartilage Tissue Engineering. *J Biomed Mater Res A*. 2019;107(8):1793-1802

Santschi M, Vernengo A, Eglin D, D'Este M, Wuertz-Kozak K. Decellularized matrix as a building block in bioprinting and electrospinning. *Curr Opin Biomed Eng*. 2019;10:116-22

Schader JF, Hudek R, Trampuz A, Scheibel M. Nachweis von Cutibacterium in der Schulterchirurgie. *Trauma und Berufskrankheit*. 2019;21:217-222

Schroeder GD, Kepler CK, Grad S, Alini M, Fang T, Markova DZ, Koerner JD, Rajasekaran S, Chapman J, Kandziora F, Schnake KJ, Dvorak MF, Oner FC, Vaccaro AR. Does Riluzole Influence Bone Formation? An *in vitro* Study of Human Mesenchymal Stromal Cells and Osteoblast. *Spine (Phila Pa 1976)*. 2019;44(16):1107-1117

Stylianaki A, Stanic B, Morgenstern M, Richards RG, Moriarty TF, Thompson K. Humoral factors from musculoskeletal polytrauma patients impair antibacterial responses of neutrophils *in vitro*. *J Bone Jt Infect*. 2019;4(6):280-4

Thompson K, Petkov S, Zeiter S, Sprecher CM, Richards RG, Moriarty TF, Eijer H. Intraoperative loading of calcium phosphate-coated implants with gentamicin prevents experimental *Staphylococcus aureus* infection *in vivo*. *PLoS One*. 2019;14(2):e0210402

Vainieri ML, Lolli A, Kops N, D'Atri D, Eglin D, Yayon A, Alini M, Grad S, Sivasubramanian K, van Osch GJVM. Evaluation of biomimetic hyaluronic-based hydrogels with enhanced endogenous cell recruitment and cartilage matrix formation. *Acta Biomater*. 2019;epub Nov 11

Vallejo A, Deimling C, Morgenstern M, D'Este M, Puetzler J, Zeiter S, Arens D, Metsemakers WJ, Richards RG, Eglin D, Moriarty TF. Local application of a gentamicin-loaded hydrogel early after injury is superior to peri-operative systemic prophylaxis in a rabbit open fracture model. *J Orthop Trauma*. 2019; epub Dec 6

Wagner D, Kamer L, Sawaguchi T, Noser H, Uesugi M, Baranowski A, Gruszka D, Rommens PM. Space available for trans-sacral implants to treat fractures of the pelvis assessed by virtual implant positioning. *Arch Orthop Trauma Surg*. 2019;139(10):1385-91

Wangler S, Menzel U, Li Z, Ma J, Hoppe S, Benneker LM, Alini M, Grad S, Peroglio M. CD146/MCAM distinguishes stem cell subpopulations with distinct migration and regenerative potential in degenerative intervertebral discs. *Osteoarthritis Cartilage*. 2019;27(7):1094-1105

Wangler S, Peroglio M, Menzel U, Benneker LM, Haglund L, Sakai D, Alini M, Grad S. Mesenchymal Stem Cell Homing Into Intervertebral Discs Enhances the Tie2-positive Progenitor Cell Population, Prevents Cell Death, and Induces a Proliferative Response. *Spine*. 2019;44(23):1613-1622

Xu Y, Peng J, Richards RG, Lu S, Eglin D. Optimization of electrospray fabrication of stem cell-embedded alginate-gelatin microspheres and their assembly in 3D-printed poly(ϵ -caprolactone) scaffold for cartilage tissue engineering. *J Orthop Translat*. 2019;18:128-141

Zderic I, Willhuber GC, Ahrend M-D, Gras F, Barla J, Sancineto C, Windolf M, Richards RG, Gueorguiev B. Biomechanical comparison between standard and inclined screw orientation in dynamic hip screw side-plate fixation: The lift-off phenomenon. *J Orthop Translat*. 2019;18:92-99

Zhang S, Hu P, Liu T, Li Z, Huang Y, Liao J, Hamid MR, Wen L, Wang T, Mo C, Alini M, Grad S, Wang T, Chen D, Zhou G. Kartogenin hydrolysis product 4-aminobiphenyl distributes to cartilage and mediates cartilage regeneration. *Theranostics*. 2019;9(24):7108-21

Ziadlou R, Barbero A, Stoddart MJ, Wirth M, Li Z, Martin I, Wang XL, Qin L, Alini M, Grad S. Regulation of inflammatory response in human osteoarthritic chondrocytes by novel herbal small molecules. *Int J Mol Sci*. 2019;20(22):E5745

14.3 2018 epub, 2019 in print – counted as published paper in 2018

Arand C, Wagner D, Richards RG, Noser H, Kamer L, Sawaguchi T, Rommens PM. 3D statistical model of the pelvic ring - a CT-based statistical evaluation of anatomical variation. *J Anat*. 2019;234(3):376-83 (epub 2018; Dec 21)

Ateschrang A, Schreiner AJ, Ahmad SS, Schröter S, Hirschmann MT, Körner D, Kohl S, Stöckle U, Ahrend MD. Improved results of ACL primary repair in one-part tears with intact synovial coverage. *Knee Surg Sports Traumatol Arthrosc*. 2019;27(1):37-43 (epub 2018; Oct 8)

Baeza J, Cury MB, Fleischman A, Ferrando A, Fuertes M, Goswami K, Lidgre L, Linke P, Manrique J, Makar G, McLaren A, Moriarty TF, Ren Q, Vince K, Wahl P, Webb J, Winkler H, Witso E, Young SW. General Assembly, Prevention, Local Antimicrobials: Proceedings of International Consensus on Orthopedic Infections. *J Arthroplasty*. 2019;34(2 Suppl):S75-S84 (epub 2018; Oct 20)

Freitag L, Günther C, Eberli U, Fürst A, Zeiter S, Stadelmann VA. Relative effects of age on implant integration in a rat model: A longitudinal *in vivo* microct study. *J Orthop Res*. 2019;37(3):541-52 (epub 2018; Dec 21)

- Gehweiler D, Teunis T, Varjas V, Kerstan D, Gueorguiev B, Kamer L, Noser H. Computerized anatomy of the distal radius and its relevance to volar plating, research, and teaching. *Clin Anat.* 2019;32(3):361-8 (epub 2018; Dec 23)
- Glatt V, Evans CH, Stoddart MJ. Regenerative rehabilitation: The role of mechanotransduction in orthopaedic regenerative medicine. *J Orthop Res.* 2019;37(6):1263-9 (epub 2018; Dec 17)
- Graceffa V, Vinatier C, Guicheux J, Stoddart M, Alini M, Zeugolis DI. Chasing Chimeras – The elusive stable chondrogenic phenotype. *Biomaterials.* 2019;192:199-225 (epub 2018; Nov 9)
- Gradl-Dietsch G, Hitpass L, Gueorguiev B, Nebelung S, Schradling S, Knobe M. Undergraduate Curricular Training in Musculoskeletal Ultrasound by Student Teachers: The Impact of Peyton's Four-Step Approach. *Z Orthop Unfall.* 2019;157(3):270-8 (epub 2018; Oct 12)
- Heriot M, Nottelet B, Garric X, D'Este M, Richards GR, Moriarty FT, Eglin D, Guillaume O. Interaction of gentamicin sulfate with alginate and consequences on the physico-chemical properties of alginate-containing biofilms. *Int J Biol Macromol.* 2019;121:390-7 (epub 2018, Oct 7)
- Knobe M, Bettag S, Kammerlander C, Altgassen S, Maier KJ, Nebelung S, Prescher A, Horst K, Pishnamaz M, Herren C, Mundt M, Stoffel M, Markert B, Gueorguiev B. Is bone-cement augmentation of screw-anchor fixation systems superior in unstable femoral neck fractures? A biomechanical cadaveric study. *Injury.* 2019;50(2):292-300 (epub 2018; Oct 30)
- Lenz M, Schwinn J, Hofmann-Fliri L, Schwyn R, Knobe M, Klos K, Kielstein H, Hofmann GO, Gueorguiev B. Influence of reduced tip-apex distance on helical blade fixation-a biomechanical study. *J Orthop Res.* 2019;37(3):649-54 (epub 2018; Dec 13)
- Rochford ETJ, Sabate Bresco M, Poulsson AHC, Kluge K, Zeiter S, Ziegler M, O'Mahony L, Richards RG, Moriarty TF. Infection burden and immunological responses are equivalent for polymeric and metallic implant materials *in vitro* and in a murine model of fracture-related infection. *J Biomed Mater Res B Appl Biomater.* 2019;107(4):1095-106 (epub 2018; Oct 17)
- Rusimov L, Zderic I, Ciric D, Barcik JP, Enchev D, Rashkov M, Hadzhinikolova M, Richards RG, Gueorguiev B, Baltov A. Does Supplemental Intramedullary Grafting Increase Stability of Plated Proximal Humerus Fractures? *J Orthop Trauma.* 2019;33(4):196-202 (epub 2018; Dec 13)
- Schmierer PA, Smolders LA, Zderic I, Gueorguiev B, Pozzi A, Knell SC. Biomechanical properties of plate constructs for feline ilial fracture gap stabilization. *Vet Surg.* 2019;48(1):88-95 (epub 2018; Nov 13)
- Schmitz P, Baumann F, Acklin YP, Gueorguiev B, Nerlich M, Grechenig S, Müller MB. Clinical application of a minimally invasive cement-augmentable Schanz screw rod system to treat pelvic ring fractures. *Int Orthop.* 2019;43(3):697-703 (epub 2018; May 21)
- Tognato R, Armiento AR, Bonfrate V, Levato R, Malda J, Alini M, Eglin D, Giancane G, Serra T. A Stimuli-Responsive Nanocomposite for 3D Anisotropic Cell-Guidance and Magnetic Soft Robotics. *Adv Funct Mater.* 2019;29(9):10 (epub 2018; Dec 18)
- Wichmann T, Moriarty TF, Keller I, Pfister S, Deggim-Messmer V, Gautier E, Kalberer F, Koch PP, Wahl P. Prevalence and quantification of contamination of knitted cotton outer gloves during hip and knee arthroplasty surgery. *Arch Orthop Trauma Surg.* 2019;139(4):451-9 (epub 2018; Nov 7)

14.4 Books / Bookchapters

Poulsson AHC, Eglin D, Richards RG. Surface Modification Techniques of PEEK, Including Plasma Surface Treatment. In: Kurtz SM (ed.). PEEK Biomaterials Handbook (Second Edition) Elsevier 2019; p. 179-201

Hickok NJ, Rochford ETJ, Jaekel DJ, Richards RG, Moriarty TF, Poulsson AHC. Bacterial Interactions With PEEK. In: Kurtz SM (ed.). PEEK Biomaterials Handbook (Second Edition) Elsevier 2019; p. 121-45

Gantenbein B, Frauchiger DA, May RD, Bakirci E, Rohrer U, Grad S. Developing Bioreactors to Host Joint-Derived Tissues That Require Mechanical Stimulation. In: Reis RL (ed.). Encyclopedia of Tissue Engineering and Regenerative **Medicine**, Elsevier 2019; p. 261-280

Hayes J.S., Richards R.G. Osseointegration of Permanent and Temporary Orthopedic Implants. In: Narayan R.(ed.). Encyclopedia of Biomedical Engineering. Elsevier 2019, pp. 257-269

14.5 Theses / Dissertations

Mys K. Cone-beam computed tomography is a fast and promising technique for microstructural imaging in clinical practice. 2019 KU Leuven (van Lenthe GH, Stockmans F, Varga P) - PhD

Nilsson J. On Virtual Surgical Planning in Cranio-Maxillofacial Surgery. Acta Universitatis Upsaliensis. 2019 Uppsala University (Thor A, Kamer L) – PhD

Pukalski Y. Management of acute paediatric Monteggia fracture-dislocation. 2019 Medical University Sofia (Baltov A, Gueorguiev B) - PhD

Riehl V. Investigation of fentanyl plasma levels after application of a fentanyl patch in three different locations in order to refine postoperative pain management in rabbits. 2019 Universität Bern (Spadavecchia C, Zeiter S) - DVM

Todorov D. Analysis of the outcomes after minimally invasive locked plating of distal femoral fractures AO 33A/33C. 2019 Medical University Sofia (Enchev D, Gueorguiev B) - PhD

Burkhard B. Experimental and computational investigation of the risk of overdrilling on the biomechanical competence of proximal humerus plating. 2019 ETH Zürich (Ferguson S, Varga P.) – MSc

Ciric D. The risk of secondary screw perforation in plate osteosynthesis of unstable proximal humerus fractures: prediction and the effect of screw length. 2019 Flinders University (Costi J, Varga P.) – MSc

Comtesse S. Prediction of Interfragmentary Movement, Loading, and Implant Strain based on Finite Element Modelling and Strain Measurements with the AO Fracture Monitor. 2019 ETH Zürich (Ferguson JS, Ernst M, Mischler D) – MSc

Jucker TA. Synthesis and characterisation of double network tough hydrogels based on natural extracellular matrix components. 2019 ETH Zürich (Ferguson SJ, Eglin D, D'Este M) – MSc

Wapp C. Secretome characterization of human mesenchymal stem cells stimulated with intervertebral disc conditioned medium – a proteomic based approach. 2019 ETH Zürich (Grad S, Würtz-Kozak K) – MSc

14.6 Abstracts published in journals

Arand C, Wagner D, Noser H, Kamer L, Richards RG, Sawaguchi T, Rommens PM. Ethnical variation in pelvic anatomy – a cohort analysis of European and Japanese pelves based on a 3D statistical CT model. *Eur J Trauma Emerg Surg.* 2019;45(Suppl 1):S40-1 (ECTES / oral)

Arens D, Zeiter S, Paulin T, Ranjan N, Alt V. Antimicrobial silver modification for locking plates shows uneventful fracture healing and good biocompatibility: results of an experimental study in rabbits. *Bone Joint J.* 2019;101-B(Suppl 14, Orthop Proc):79 (EBJIS / oral)

Boot W, Foster AL, Zeiter S, Schmid T, D'Este M, Eglin D, Richards RG, Moriarty TF. Antibiotic-loaded hydrogel outperforms clinical gold standard treatment in a large animal model of methicillin-resistant *staphylococcus aureus* implant-associated osteomyelitis. *Bone Joint J.* 2019;101-B(Suppl 14, Orthop Proc):75 (EBJIS / oral)

Burch M-A, Zeiter S, Richards RG, Moriarty TF, Thompson K. Non-Steroidal Anti-Inflammatory Drug Administration Impairs Antibiotic Treatment of Osteosynthesis-Device Related Infection in a Rat Model. *Bone Joint J.* 2019;101-B(Suppl 14, Orthop Proc):87 (EBJIS / oral)

Häckel S, Li Z, Yayon A, Zolfaghar M, Hoppe S, Benneker LM, Alini M, Grad S. One-way Street Disc Degeneration? An Investigation of Hydrogel and Fibroblast Growth Factor 18 (FGF-18) for Intervertebral Disc Regeneration. *Swiss Med Wkly.* 2019;149(Suppl 236):25-6S (Swiss Orthopaedics / oral)

Grad S, Wangler S, Peroglio M, Menzel U, Benneker LM, Haglund L, Sakai D, Alini M. Homing of mesenchymal stem cells into degenerative intervertebral disc – Effect on disc cell survival. *Bone Joint J* 2019;101-B(Suppl 10, Orthop Proc) (SBPR (poster)

Haeckel S, Li Z, Yayon A, Hoppe S, Benneker L, Alini M, Grad S. One-Way Street Disc Degeneration? An Investigation of Hydrogel and Fibroblast Growth Factor 18 (FGF-18) for Intervertebral Disc Regeneration. *Global Spine J.* 2019;9(2 Suppl):341S-2S (Global Spine Congress / poster)

Krause F, Zderic I, Gueorguiev B, Schmid T. The effect of subtalar motion on calcaneal osteotomies. *Swiss Med Wkly.* 2019;149(Suppl 236):9S (Swiss Orthopaedics / oral)

Lackington W, Gomez M, Hildebrand M, Alini M, Zeiter S, Thompson K. Local administration of IL-1Ra as a strategy to enhance long bone healing. *J Bone Miner Res.* 2019;34(Suppl 1):388 (ASBMR / poster)

Lang G, Li Z, Gehlen Y, Heizmann F, Kubosch D, Südkamp N, Alini M, Grad S. Preclinical Testing of Anti-Inflammatory Compounds Using a Whole Intervertebral Disc Organ Culture Model. *Global Spine J.* 2019;9(2 Suppl):97S-8S (Global Spine Congress)

Pfannkuche J, Kubosch D, Südkamp N, Alini M, Grad S, Li Z, Lang G. In vitro analysis of the protective effect of Losartan in the treatment of degenerative disc disease. *Eur Spine J.* 2019;28(11):2666 (DWK / oral)

Pützler J, Alexander M, Everding J, Raschke MJ, Arens D, Zeiter S, Richards RG, Moriarty TF. High-energy focused extracorporeal shockwave therapy in addition to conventional treatment: results from an in vivo rabbit model of fracture-related infection. *Bone Joint J.* 2019;101-B(Suppl 14, Orthop Proc):78 (EBJIS / oral)

Wangler S, Peroglio M, Li Z, Menzel U, Benneker LM, Richards RG, Alini M, Grad S. Homing of Mesenchymal Stem Cells Into Degenerated Intervertebral Discs: An Alternative to Stem Cell Injection? *Global Spine J.* 2019;9(2 Suppl):198S-9S (Global Spine Congress / poster)

14.7 Abstracts (conference participations)

Alini M. Hyaluronan hydrogel platform for musculoskeletal regeneration. 2019 TERMIS EU (oral)

Antunes BP, Vainieri ML, Monsonogo-Ornan E, Alini M, Grad S, Yayon A. Effects of mechanical stimulation combined with FGF-18 on bovine chondrocytes embedded in a novel Fibrin:Hyaluronan hydrogel. 2019 ORS (poster)

Arand C, Wagner D, Noser H, Kamer L, Richards RG, Sawaguchi T, Rommens PM. 3D statistisches Modell des Beckenrings – CT basierte Analyse interindividueller anatomischer Variabilität. 2019 VSOU (oral)

Arand C, Wagner D, Noser H, Kamer L, Gehweiler D, Richards RG, Rommens P. Percutane retrograde transpubische Schraubenosteosynthese - anatomische Analyse des Schraubenkorridors basierend auf einem 3D statistischen Modell des Beckenrings. 2019 DKOU (oral)

Ahrend M-D, Noser H, Shanmugam R, Kamer L, Burr F, Hügli H, Zaman TK, Richards RG, Gueorguiev B. Evidence-based generic Asian pelvic bone models for research, development and teaching using CT-based 3D statistical modeling. 2019 EFORT (poster)

Ahrend M-D, Noser H, Shanmugam R, Kamer L, Burr F, Hügli H, Zaman T, Richards RG, Gueorguiev B. Evidence-based generic Asian pelvic bone models for research, development and teaching using CT-based 3D statistical modeling. 2019 ICORS (poster)

Ahrend M-D, Zderic I, Noser H, Shanmugam R, Kamer L, Burr F, Hügli H, Kamarul T, Richards RG, Gueorguiev B. Evidence-based generic Asian pelvic bone models for research, development and teaching using CT-based 3D statistical modeling. 2019 EORS (oral)

Arens D, Zeiter S, Ranjan N, Paulin T, Alt V. Antimicrobial silver-modification for locking plates shows uneventful fracture healing and good biocompatibility – Results of an experimental study in rabbits. 2019 EFORT (poster)

Arens D, Zeiter S, Ranjan N, Paulin T, Alt V. Silber-beschichtete winkelstabile Platten zeigen ungestörte Frakturheilung und gute Biokompatibilität im Kaninchenmodell. 2019 DKOU (oral)

Barcik J, Ernst M, Freitag L, Dlaska C, Drenchev L, Gueorguiev B, Skulev H, Mys K, Epari D, Windolf M. Automated active fixation system to test the influence of different loading regimes on fracture healing. 2019 ESBioMech (poster)

Barcik J, Ernst M, Schwyn R, Freitag L, Dlaska C, Drenchev L, Todorov S, Gueorguiev B, Skulev H, Epari D, Windolf M. Development of tailor-made equipment for experimental preclinical surgeries using computer simulations and 3D printing. 2019 ICMCC (oral)

Barcik J, Ernst M, Freitag L, Dlaska CE, Drenchev L, Todorov S, Gueorguiev B, Skulev H, Zeiter S, Epari D, Windolf M. Automated electromechanical system designed to investigate the effect of local mechanical conditions on fracture healing progression. 2019 EORS (oral)

Barcik J, Ernst M, Balligand M, Dlaska CE, Drenchev L, Todorov S, Gueorguiev B, Skulev H, Zeiter S, Epari D, Windolf M. Continuous monitoring of fracture healing to analyze short-term response of bone repair tissue to mechanical stimulation. 2019 EORS (oral)

Barcik J, Ernst M, Balligand M, Dlaska CE, Drenchev L, Todorov S, Skulev H, Zeiter S, Epari D, Windolf M. Analysis of the short-term response of fracture repair tissue to mechanical stimulation. 2019 TERMIS AP + ABMC (poster)

Barcik J, Ernst M, Freitag L, Dlaska C, Drenchev L, Todorov D, Skulev H, Zeiter S, Epari D, Windolf M. Automated active fixation system designed to investigate the influence of local mechanical environment on fracture healing. 2019 TERMIS AP + ABMC (poster)

Basoli V, Kovermann N, Della Bella E, Alini M, Lischer C, Schmal H, Kubosch EJ, Stoddart MJ. BMP2 and TGF- β differentially cooperate during synovial derived stem cell chondrogenesis in a dexamethasone dependant manner. 2019 ORS (ICORS best posters)

Basoli V, Della Bella E, Alini M, Stoddart MJ. Role of dexamethasone and (+)-ZK 216348 during chondrogenic fate in bone marrow stem cells. 2019 TERMIS EU (oral)

Behrendt P, Ladner Y, Stoddart MJ, Lippross S, Alini M, Eglin D, Armiento AR. Highly tunable hyaluronan-derived hydrogel to study mechanoregulated chondrogenesis of human MSCs. 2019 ORS (poster)

Behrendt P, Ladner Y, Lippross S, Alini M, Stoddart M, Eglin D, Armiento A. Joint mimicking mechanical loading activates endogenous TGF- β 1 in a cellularized bioadhesive hydrogel eligible for cartilage regeneration. 2019 AGA (poster)

Behrendt P, Ladner Y, Stoddart MJ, Lippross S, Alini M, Eglin D, Armiento AR. Joint mimicking mechanical load activates endogenous TGF- β in a highly cellularized bioadhesive hydrogel for cartilage repair. 2019 SBMS (oral)

Binch ALA, Basatvat S, Owen D, Snuggs J, Richardson S, Hoyland JA, Gansau J, Buckley CT, Glaeser JD, Sheyn D, Wang D, Vo N, Jacobsen T, Chahine NO, Presciutti SM, Drissi H, Yoon T, Gawri R, Lang G, Hernandez PA, Fearing BV, Setton LA, Gullbrand SE, Dudli S, Schol J, Sakai D, Guerrero J, Gantenbein B, Li Z, Peroglio M, Alini M, Grad S, Kraus P, Lufkin T, O'Donnell GD, Dahia C, Takashi K, Kushioka J, Wachs RA, DiStefano T, Panebianco C, Illien-Junger S, Iatridis JC, Bowles RD, Sun Y, Leung VY, Haglund L, Mizuno S, Huang C-Y, Alvarez-Garcia O, Silverman L, Li X, Garcia JP, Creemers LB, Ito K, Bach F, Tryfonidou M, LeMaitre CL. Harmonization and Standardization of Intervertebral Disc Cell Culture Methods. 2019 ORS PSRS (oral)

Boot W, Schmid T, Guillaume O, D'Este M, Foster A, Eglin D, Richards RG, Zeiter S, Moriarty TF. Antibiotic-loaded hydrogel demonstrates superior efficacy to bone cement in treating MRSA implant-associated osteomyelitis in sheep. 2019 eCM (oral)

Boot W, Zeiter S, D'Este M, Eglin D, Foster A, Schmid T, Guillaume O, Richards RG, Moriarty TF. A Vancomycin and Gentamicin-Loaded Thermo-responsive Hydrogel Successfully Treats Chronic MRSA Implant-Associated Osteomyelitis in a Sheep Model. 2019 SGM – SSM (poster)

Breden S, Chamseddine M, Varga P, Müller PE, Pietschmann MF, Chevalier J. High-resolution CT based assessment of the influence of bone quality on anatomical glenoid component loosening. 2019 ESBioMech (oral)

Burch M-A, Kühl R, Morgenstern M, Metsemakers W-J. Osteosynthesis device retention in fracture related infection: investigating time limitations. 2019 eCM (poster)

Chen Y, Post V, Moriarty TF, Richards RG, Boot W. Synergism between Traditional Chinese Medicine compounds and antibiotics against *Staphylococcus aureus*. 2019 eCM (poster)

Ciric D, Mischler D, Qawasmi F, Wenzel L, Windolf M, Gueorguiev B, Varga P. Longer screws do not increase perforation risk in plating of complex proximal humerus fractures *in vitro*. 2019 ESBioMech (oral)

Ciric D, Mischler D, Qawasmi F, Windolf M, Gueorguiev B, Varga P. Predicting cyclic screw perforation in complex proximal humerus fracture plating. 2019 ESBioMech (oral)

Dal Fabbro LT, Lurf R, Schmid B, Baumgartner D, Vainieri L. Biological response of Polycarbonate-Urethane articulation on cartilage – a pin-on-disc *in vitro* study. 2019 SSB+RM (poster)

Dasen B, Guerrero J, Scherberich A, Verrier S, Martin I, Philippova M. Regulation of pericyte function in angiogenesis and tissue regeneration: The role for T-cadherin. 2019 TERMIS EU (oral)

Della Bella E, Basoli V, Alini M, Stoddart MJ. Dexamethasone drives early osteogenic differentiation by modulation of SOX9 and PPAR γ expression. 2019 TERMIS EU (oral)

D'Este M. Towards Clinical Translation: Patents and Intellectual Property in Biomaterials Science. 2019 Royan SCBT (oral)

D'Este M, Moriarty TF. Local antibiotics delivery with hydrogels: from infection prevention to infection eradication in orthopedic trauma. 2019 ESBioMat (oral)

D'Este M. From bench science to clinical translation: patents in biomaterials. 2019 ESBioMat (oral)

Du J, Long RG, Sakai D, Benneker LM, Iatridis JC, Alini M, Grad S, Li Z. Cell seeded collagen-polyurethane scaffold supplemented with TGF β for annulus fibrosus repair. 2019 TERMIS EU (oral)

Eglin D. Fabrication of stimuli responsive hydrogel microenvironments for cell manipulation. 2019 TERMIS EU (oral)

Eglin D. High-fidelity orbital floor repair using patient specific osteoinductive implant made by stereolithography. 2019 IS2M (oral)

Eglin D. Personalised bioactive implant made by stereolithography for orbital floor. 2019 ICORS (oral)

Escalante I, Zderic I, Schopper C, Richards RG, Gueorguiev B, Kfuri M. Biomechanical investigation of locked mesh plating and tension band wiring of complex patella fractures. 2019 ESBioMech (oral)

Fletcher J, Neumann V, Wenzel L, Gueorguiev B, Richards RG, Whitehouse M, Gill H, Preatoni E. Assessing screw tightness and stripping rates achieved by orthopaedic surgeons and researchers, including using an augmented screwdriver. 2019 EFORT (poster)

Fletcher J, Wenzel L, Gueorguiev B, Richards RG, Gill H, Whitehouse M, Preatoni E. Assessing screw tightness achieved by orthopaedic surgeons and researchers. 2019 ICORS (poster)

Fletcher J, Windolf M, Gueorguiev B, Richards RG, Varga P. SystemFix – Using computer simulations to optimise proximal humeral fracture fixation. 2019 ICORS (oral)

Fletcher J, Windolf M, Richards RG, Gueorguiev B, Varga P. Optimising proximal humerus fracture plating – discoveries from computer simulations. 2019 LSM (winner poster presentation)

Fletcher J, Neumann V, Silva J, Mys K, Panagiotopoulou V, Verschueren A, Gueorguiev B, Richards RG, Whitehouse M, Preatoni E, Gill H. TightRight: augmenting screwdrivers to reduce bone stripping rates and optimise tightness when inserting non-locking screws. 2019 BRS & BORS (oral)

Fletcher J, Zderic I, Gueorguiev B, Richards RG, Gill H, Whitehouse M, Preatoni E. What is the optimum tightness for non-locking cortical screws, and how can this be predicted prior to insertion? 2019 BRS & BORS (poster)

Fletcher J, Neumann V, Silva J, Mys K, Panagiotopoulou V, Gueorguiev B, Richards RG, Whitehouse M, Preatoni E, Gill H. Augmented screwdrivers greatly reduce bone stripping rates and optimise tightness when used to insert non-locking screws. 2019 BOA (poster)

Frauchiger DA, Tekari A, May R, Džafo E, Chan SCW, Stoyanov J, Bertolo A, Zhang X, Sakai D, Schol J, Grad S, Tryfonidou M, Benneker LM, Gantenbein B. Different isolation methods for nucleus pulposus progenitor cells. 2019 BioSpine (poster)

Frauchiger DA, May RD, Džafo E, Zhang X, Stoyanov J, Bertolo A, Benneker LM, Sakai D, Grad S, Tryfonidou M, Gantenbein B. FACS reveals more Pluripotent Intervertebral Disc Progenitor Cells compared to MACS and pluriSelect. 2019 TERMIS EU (poster)

Ganse B, Böhle F, Pastor T, Gueorguiev B, Altgassen S, Gradl G, Kim B-S, Modabber A, Nebelung S, Hildebrand F, Knobe M. Microcirculation after trochanteric femur fractures: A prospective cohort study using non-invasive laser-doppler spectrophotometry. 2019 EFORT (poster)

Gomez-Sierra MA, Lackington WA, Alini M, Thompson K. Local non-viral gene delivery to immunomodulate and enhance fracture healing. 2019 EORS (oral)

Gomez-Sierra MA, Lackington WA, Alini M, Thompson K. Local non-viral gene delivery to immunomodulate and enhance fracture healing. 2019 SBMS (oral)

Gueorguiev B, Ernst M, Windolf M. From wearables to smart implants: The AO Fracture Monitor to assess bone healing. 2019 ICORS (oral)

Gueorguiev B, Stoddart M, Zeiter S, Richards RG. AO translational research and development. 2019 ICMCC (oral)

Gueorguiev B, Stoddart M, Zeiter S, Richards RG. AO preclinical research and development. 2019 BOTTA (oral)

Gurung R, Windolf M, Schwyn R, Zeiter S, Epari D, Hofmann-Fliri L. Novel dynamic plating concept to improve the biomechanics of internal fixation. 2019 AOTAP (oral / best paper award)

Häckel S, Li Z, Zolfaghar M, Yayon A, Hoppe S, Benneker L, Alini M, Grad S. One-way Street Disc Degeneration? An Investigation of Hydrogel and Fibroblast Growth Factor 18 (FGF-18) for Intervertebral Disc Regeneration. 2019 DKOU (oral)

Häckel S, Zolfaghar M, Du J, Hoppe S, Benneker LM, Peroglio M, Alini M, Grad S, Yayon A, Li Z. Fibrin-hyaluronic acid hydrogel and Fibroblast Growth Factor-18 for Intervertebral Disc Regeneration: an in vitro study on bovine and human nucleus pulposus cells. 2019 ORS PSRS (poster)

Hadzhinikolova M, Zderic I, Ciric D, Enchev D, Baltov A, Rusimov L, Richards RG, Rashkov M, Gueorguiev B. Does supplemental dorsal plating increase stability of distal radius fractures after volar plating? 2019 ICORS (oral)

Hadzhinikolova M, Zderic I, Ciric D, Barcik J, Enchev D, Rusimov L, Richards RG, Gueorguiev B, Baltov A, Rashkov M. Does supplemental dorsal locked plating increase stability of complex distal radius fractures after volar locked plating? 2019 BOTTA (oral)

Harris LG, Mageiros L, Post V, Mack D, Rohde H, Moriarty TF, Wilkinson TS. Temporal changes in patient matched *Staphylococcus epidermidis* samples from medical device associated infections. 2019 eCM (poster)

Hatt LP, Thompson K, Müller WEG, Stoddart MJ, Armiento AR. Calcium polyphosphate-nanoparticles act as an effective inorganic phosphate source during the in vitro osteogenic differentiation of human bone marrow-derived MSCs. 2019 SBMS (oral)

Hofmann-Fliri L, Epari D, Schwyn R, Zeiter S, Windolf M. Biphasic Plating – *In vivo* study on a novel fixation concept to enhance mechanobiological fracture healing. 2019 EORS (oral)

Hofstee M, Richards RG, Moriarty TF, Zaat SAJ. A novel 3-dimensional multicellular *in vitro* model for *Staphylococcus aureus* microcolony interaction with neutrophils. 2019 WIRM (poster)

Hofstee M, Riool M, Zaat SAJ, Richards RG, Moriarty TF. A novel 3-dimensional multicellular *in vitro* model for *Staphylococcus aureus* microcolony interaction with neutrophils. 2019 eCM (poster)

Hofstee M, Riool M, Thompson K, Stoddart MJ, Zaat SAJ, Moriarty TF. A novel 3-dimensional *in vitro* model for osteomyelitis associated staphylococcal abscess communities. 2019 EORS (oral)

Jorge-Mora A, Keltz E, Neumann V, Richards RG, Gueorguiev B, Gill H, Whitehouse M, Preatoni E, Fletcher J. The effect of grip configuration on achieved non-locking screw tightness. 2019 EFORT (poster)

Jorge Mora A, Keltz E, Fletcher J, Gueorguiev B, Cabrillo Estévez C, Viana Giorno C. ¿Es la inserción de tornillos con 2 dedos más segura? 2019 SECOT (poster)

Klink J, Ihle C, Ateschrang A, Gueorguiev B, Stöckle U, Schreiner AJ, Schröter S. Präoperatives klinisches Scoring als prädiktiver Faktor für die Überlebensrate nach valgusierender open wedge HTO. 2019 DKOU (oral)

Klos K, Simons P, Gueorguiev B, Richards RG, Krause F, Knobe M, Penev P. Einfluss verschiedener Verletzungen des Lisfranc-Komplexes - Eine CT basierte Kadaverstudie. 2019 DAF (poster)

Knobe M, Link B, Beeres F, Gueorguiev B, Modabber A, Horst K, Lichte P, Klos K. Mikrozirkulation bei der intraartikulären Kalkaneusfraktur: Können wir Wundheilungsstörungen vorhersagen? 2019 DKOU (oral)

Krause F, Zderic I, Gueorguiev B, Schmid T. The effect of subtalar motion on calcaneal osteotomies. 2019 EFORT (oral)

Lackington W, Hildebrand M, Alini M, Zeiter S, Stoddart M, Thompson K. Controlled delivery of IL-1Ra to enhance long bone healing. 2019 TERMIS EU (oral)

Lackington W, Hildebrand M, Alini M, Zeiter S, Thompson K. Local delivery of IL-1Ra as a strategy to enhance long bone healing. 2019 SBMS (oral)

Lang G, Gehlen Y, Heizmann F, Kubosch D, Südkamp N, Alini M, Grad S, Li Z. Pre-clinical testing of anti-inflammatory compounds in an intervertebral disc organ culture model. 2019 BioSpine (oral)

Lang G, Wystrach L, Kubosch D, Südkamp N, Bernstein A, Alini M, Grad S, Li Z. The Tissue-Renin-Angiotensin-System of the Human Intervertebral Disc. 2019 ORS (DGOU best poster)

Lee CC, Muthukrishnan G, Owen JR, Kates SL, Beck CA, Daiss JL, Post V, Moriarty TF, Zeiter S, Schwarz EM. Deriving a dose and regimen for anti-glucosaminidase antibody passive-immunization for patients with *S. aureus* osteomyelitis. 2019 eCM (oral)

Li Z. Annulus fibrosus repair with endogenous cell activation and function inducing cell transplantation. 2019 ICORS (oral)

Li Z, Du J, Long RG, Sakai D, Benneker LM, Iatridis JC, Alini M, Grad S. Functional cell phenotype induction with TGF β 1 and collagen-polyurethane scaffold for annulus fibrosus repair. 2019 ORS PSRS (poster)

Li Z, Gehlen Y, Heizmann F, Kubosch D, Südkamp N, Alini M, Grad S, Lang G. Pre-clinical testing of anti-inflammatory and regenerative drug therapy in a bioreactor-guided intervertebral disc organ culture model. 2019 ORS PSRS (poster)

Lolli A, Sivasubramaniyan K, Vainieri ML, Kops N, Yayon A, van Osch GJVM. AntimiR-221 activated hydrogels enhance cartilage repair by endogenous cells *in vivo*. 2019 TERMIS EU (oral)

Ma J, Stefanoska D, Grad S, Alini M, Peroglio M. Low pH culture of dorsal root ganglion cells as an *in vitro* model to study pathological changes involved in the development of neuropathic pain. 2019 NeuPSIG (poster)

Ma J, Stefanoska D, Grad S, Alini M, Peroglio M. Hypoxic stress enhances extension and branching of sensory neuronal outgrowth: a comparison between *in vitro* and ex vivo model. 2019 NeuPSIG (poster)

Ma J, Stefanoska D, Hildebrand M, Zeiter S, Alini M, Peroglio M. Validation of cell line models to study intervertebral disc neo-innervation associated with discogenic pain. 2019 Swiss 3Rs Day (poster)

Ma J, Stefanoska D, Grad S, Alini M, Peroglio M. Effect of pH and oxygen tension on dorsal root ganglion calcium response to bradykinin and neurite sprouting. 2019 Pain in EU (poster)

Ma J, Stefanoska D, Grad S, Alini M, Peroglio M. Hypoxia and low pH stressed disc conditioned medium promotes hypersensitivity of peripheral sensory neurons. 2019 ORS PSRS (poster)

Makelov B, Silva JD, Apivatthakakul T, Gueorguiev B, Varga P. Externalized locked plating of unstable proximal tibia fractures can provide sufficient stability under partial weightbearing. A finite element study. 2019 EFORT (oral)

Makelov B, Zderic I, Silva JD, Apivatthakakul T, Gueorguiev B, Varga P. Externalized locked plating of unstable proximal tibia fractures can provide sufficient stability under partial weightbearing – a finite element study. 2019 EORS (oral)

Makelov B, Silva JD, Apivatthakakul T, Gueorguiev B, Varga P. External one-staged locked plating of unstable proximal tibia fractures can provide callus formation and sufficient stability under partial weightbearing. A finite element study. 2019 BOTTA (poster)

Milstrey A, Pützler J, Everding J, Richards RG, Moriarty TF, Raschke M. Fokussierte hochenergetische Stosswellentherapie (fhESWT) reduziert *Staph. aureus* Biofilm *in vitro*. 2019 DKOU (oral)

Milstrey A, Pützler J, Everding J, Arens D, Zeiter S, Richards RG, Moriarty TF, Raschke M. Fokussierte hochenergetische Stosswellentherapie (fhESWT) führt nicht zu septischer Streuung bei florider Infektion im Kaninchen Frakturmodell. 2019 DKOU (poster)

Mischler D, Windolf M, Varga P. Computational optimization of the locking screw angles of a proximal humerus plate. 2019 ESBioMech (oral)

Mischler D, Schader J, Windolf M, Varga P. Improving fixation techniques of proximal humerus fractures by means of finite element analysis. 2019 EORS (oral)

Monaco G, Alini M, El Haj A, Stoddart MJ. Hyaluronan supplemented culture media significantly increases early chondrogenesis glycosaminoglycan synthesis and reduces the upregulation of collagen X in a stem cell-based implant. 2019 TERMIS EU (oral)

Mys K, Varga P, Stockmans F, Gueorguiev B, Wyers CE, van den Bergh JPW, van Lenthe GH. Cone-Beam computed tomography as a fast alternative for high-resolution peripheral computed tomography. 2019 QMSKI (oral)

Mys K, Zhang G, Stockmans F, Wyers CE, van den Bergh JPW, van Lenthe GH. X-ray scattering is limited in cone-beam computed tomography of extremities. 2019 QMSKI (oral)

Mys K, Varga P, Stockmans F, Gueorguiev B, Wyers CE, van den Bergh JPW, van Lenthe GH. Influence of the analysis software to calculate direct bone structural parameters. 2019 QMSKI (poster)

Mys K, Varga P, Stockmans F, Gueorguiev B, Neumann V, Vanovermeire O, Wyers CE, van den Bergh JPW, van Lenthe GH. Cone-beam CT as a fast and promising technique to assess the microstructure of distal radii in clinical practice. 2019 ESBioMech (oral)

Neumann V, Fletcher J, Wenzel L, Gueorguiev B, Richards RG, Whitehouse M, Gill H, Preatoni E. The effect of different insertion variables on achieved screw tightness and stripping rates for non-locking screws. 2019 EFORT (oral)

Neumann V, Wenzel L, Gueorguiev B, Richards RG, Gill H, Whitehouse M, Preatoni E, Fletcher J. The effects of different insertion variables on achieved screw tightness. 2019 ICORS (oral)

Nowak T, Wagner D, Kamer L, Noser H, Rommens PM. Anzahl möglicher trans-sakraler Implantate im Becken anhand virtueller Implantatpositionierung. 2019 VSOU (oral)

Otto S, Pautke C, Arens D, Poxleitner P, Eberli U, Nehrbass D, Zeiter S, Stoddart MJ. Investigation into the prevention of BRONJ in the minipig large animal model – is there a role of drug holiday? 2019 ICORS (poster)

Pellicciotta D, Richards RG, Eglin D, Alini M, Serra T. A sound-induced technology for multiscale organization of perfusable micro-vessels networks. 2019 TERMIS EU (oral)

Penev P, Simons P, Qawasmi F, Gueorguiev B, Richards RG, Krause F, Knobe M, Klos K. Ligamentous Lisfranc injuries. CT study with weightbearing on cadavers. 2019 BFAS, Sofia

Penev P, Qawasmi F, Mosheiff R, Knobe M, Krause F, Richards RG, Gueorguiev B, Klos K. Influence of different Lisfranc ligament injuries on CT Findings – A human cadaver study. 2019 EFORT (poster)

Penev P, Klos K, Qawasmi F, Mosheiff R, Knobe M, Krause F, Richards RG, Gueorguiev B. Impact of Lisfranc ligament injuries on CT findings under weightbearing. 2019 ESBioMech (oral)

Penev P, Zderic I, Qawasmi F, Mosheiff R, Knobe M, Krause F, Richards RG, Raykov D, Gueorguiev B, Klos K. Influence of different Lisfranc ligament injuries on CT findings. 2019 EORS (oral)

Penev P, Klos K, Qawasmi F, Mosheiff R, Knobe M, Krause F, Richards RG, Gueorguiev B. Ligamentous Lisfranc injury – analysis of CT findings under weightbearing. 2019 BOTA (oral)

Pereira AR, Gehweiler D, Trivanović D, Kreuzahler T, Herrmann M. A human bone-derived 3D scaffold for studying MSC interactions within the skeletal niche. 2019 TERMIS EU (oral)

Petta D, Grijpma DW, Alini M, Eglin D, D'Este M. 3D Printing of a Hyaluronan Bioink With Double Gelation Mechanism for Independent Tuning of Shear-Thinning and Shape Fixation. 2019 Royan SCBT (oral)

Puetzler J, Milstrey A, Everding J, Raschke M, Arens D, Zeiter S, Richards RG, Moriarty TF. Combination of high-energy focused extracorporeal shockwave therapy with conventional treatment: Results from an *in vivo* rabbit model of fracture related infection. 2019 eCM (oral)

Pukalski Y, Yanev P, Baltov A, Rashkov M, Schmidutz F, Zderic I, Sprecher C, Richards RG, Gueorguiev B, Enchev D. Impact of Titanium Elastic Nail pre-contouring on the fixation of paediatric diaphyseal forearm fractures. 2019 ESBioMech (poster)

Pukalski Y, Yanev P, Rashkov M, Schmidutz F, Zderic I, Sprecher C, Richards RG, Gueorguiev B, Baltov A, Enchev D. Influence of titanium elastic nail pre-contouring on the fixation of paediatric diaphyseal forearm fractures. 2019 Osteosynthese International (oral)

Pukalski Y, Yanev P, Rashkov M, Schmidutz F, Zderic I, Sprecher C, Richards RG, Gueorguiev B, Baltov A, Enchev D. Impact of titanium elastic nail pre-contouring on the fixation of paediatric diaphyseal forearm fractures. 2019 EORS (poster)

Pukalski Y, Yanev P, Rashkov M, Schmidutz F, Zderic I, Sprecher C, Richards RG, Gueorguiev B, Baltov A, Enchev D. Impact of titanium elastic nail prebending in the treatment of AO PCCF 22D/4.1 pediatric forearm fractures. 2019 BOTA (oral)

Rotman SG, Grijpma DW, Richards RG, Moriarty TF, Eglin D, Guillaume O. Surface modification of drug delivery microspheres to enhance affinity to bone. 2019 SSB+RM (poster)

Rotman S, Wang M, Yang S, Grijpma DW, Richards RG, Moriarty TF, Eglin D, Tang TT, Guillaume O. Antibiotic loaded poly(ϵ -caprolactone) microspheres functionalized with poly(aspartic acid) as bone targeting delivery system to treat infection. 2019 TERMIS EU (oral)

Rotman SG, Wang M, Yang S, Grijpma DW, Richards RG, Moriarty TF, Eglin D. Gentamicin-AOT loaded poly(ϵ -caprolactone) microspheres functionalized with poly(aspartic acid) as bone targeting delivery system tested in a rat osteomyelitis model. 2019 eCM (poster)

Rotman S, Wang M, Yang S, Grijpma D, Richards RG, Eglin D, Moriarty TF, Tang TT, Guillaume O. Microparticles with enhanced bone affinity for efficient antibiotic delivery to infected bone fractures. 2019 ESBioMat (oral)

Rusimov L, Zderic I, Ciric D, Barcik J, Enchev D, Rashkov M, Hadzhinikolova M, Richards RG, Baltov A, Gueorguiev B. Does supplemental intramedullary grafting increase stability of plated proximal humerus fractures? 2019 ICORS (poster)

Rusimov L, Zderic I, Ciric D, Barcik J, Rashkov M, Hadzhinikolova M, Richards RG, Gueorguiev B, Enchev D, Baltov A. Unstable proximal humerus fractures: Benefits of using intramedullary graft in locked plate fixation. 2019 BOTA (oral)

Schönweger F, Sprecher CM, Neels A, Dommann A, Meier C, Wahl P. Delamination of the Hydroxyapatite Coating from the Stem 14 Months after Total Hip Arthroplasty. 2019 IMOR (oral)

Schol J, Sakai D, Warita T, Peroglio M, Li Z, Zeiter S, Grad S, Alini M. Locally delivered mesenchymal stem cell homing enables intervertebral disc repair: A proof-of-concept study. 2019 ORS PSRS (oral)

Schopper C, Zderic I, Menze J, Müller D, Rocci M, Knobe M, Shoda E, Richards RG, Gue B. Better Stability and More Predictive Fixation of the Femoral Neck System versus Two Hansson Pins in Pauwels II Femoral Neck Fractures – A Biomechanical Study. 2019 EORS (oral)

Schwab A, Ambrosio L, Alini M, Eglin D, D'Este M. Hyaluronic acid collagen biomaterial ink with anisotropic properties to control cellular organization. 2019 SSB+RM (poster)

Schwab A, Ambrosio L, Alini M, Eglin D, D'Este M. Anisotropic properties of a hyaluronic acid collagen biomaterial ink to control cellular behavior. 2019 TERMIS EU (poster)

Sennett ML, Friedman JM, Ashley BS, Stoeckl BD, Patel JM, Alini M, Cucchiari M, Eglin D, Madry H, Mata A, Semino C, Stoddart M, Moutos FT, Estes BT, Guilak F, Mauck RL, Dodge GR. Long Term Outcomes of Biomaterial-Mediated Repair of Focal Cartilage Defects in a Large Animal Model. 2019 ORS (oral)

Serra T. A sound-induced technology for multiscale organization of perfusable micro-vessels networks. 2019 EMBO/ EMBL symposium (poster)

Serra T, Pellicciotta D, Basoli V, Della Bella E, Armiento AR, Richards RG, Alini M, Eglin D. Spatially orchestrated micro-vessels networks via acoustic waves cell patterning. 2019 SSB+RM

Serra T. A sound-induced technology for multiscale orchestration of functional vessels networks. 2019 ATSM (poster)

Sheehy EJ, von Diemling C, Moriarty TF, O'Brien FJ. Antibiotic-Eluting Collagen-Hydroxyapatite Scaffolds Eradicate Infection and Facilitate Bone Healing in a Rabbit Model of Osteomyelitis. 2019 ORS (oral)

Sheehy EJ, von Diemling C, Moriarty TF, O'Brien FJ. Antibiotic-eluting scaffolds eliminate infection and facilitate bone tissue. 2019 ICORS (oral)

Sheehy EJ, von Diemling C, Moriarty TF, O'Brien FJ. Antibiotic-eluting scaffolds eradicate infection and facilitate bone regeneration in a rabbit model of osteomyelitis. 2019 eCM (oral)

Silva-Henao J, Ovesy M, Fletcher JWA, Gueorguiev B, Zysset PK, Varga P. Nonlinear explicit μ FE models predict axial pull-out force of cortical screws in human tibia. 2019 ESBioMech (oral)

Stadelmann VA, Thompson K, Eberli U, Arens D, Richards RG, Moriarty TF. Impact of osteoporosis and bisphosphonate on *Staphylococcus epidermidis* implant infection and response to antibiotic treatment. 2019 eCM (poster)

Stefanoska D, Ma J, Grad S, Alini M, Peroglio M. Effects of glucose concentration and pH on dorsal root ganglion neurite outgrowth. 2019 Pain (poster)

Stoddart MJ. Physical modulation to divert stem cells to chondrogenic cell fate. 2019 ORS (oral / ICORS symposium)

Stoddart MJ. Role of kinematic load on cell behavior. 2019 TERMIS EU (oral)

Stoddart M, Alini M. How to publish in eCM - a journal founded and run by scientists for the benefit of science rather than profit. 2019 ICORS (oral)

Stoddart MJ. Stem Cells without the hype: What is the real science? 2019 ICRS (oral)

Thompson K, Arens D, Eberli U, Richards RG, Stadelmann VA, Moriarty TF. Impact of NSAID administration on *Staphylococcus epidermidis* implant-related infection and response to antibiotic treatment. 2019 ORS (poster)

Thompson K, Burch M-A, Milstrey A, Eberli U, Arens D, Richards RG, Stadelmann VA, Moriarty TF. Non-steroidal anti-inflammatory drug administration impairs antibiotic treatment of orthopaedic-device related infection in a rat model. 2019 eCM (oral)

Varga P, Gueorguiev B, Richards RG, Windolf M. Smart surgery – translational research and development at the AO Research Institute Davos. 2019 HSS Exp Surg (oral)

Vainieri ML, Lolli A, Sivasubramaniyan K, Eglin D, Yayon A, Alini M, Grad S, van Osch G. Biomimetic hyaluronic-based hydrogel enhances endogenous cell recruitment and healing process of osteochondral lesions. 2019 TERMIS EU (oral)

Vernengo A, Li Z, Grad S, Eglin D, Alini M. Development and characterization of 3D printed scaffolds for annulus fibrosus regeneration. 2019 BioSpine (poster)

Vernengo AJ, Li Z, Grad S, Eglin D, Alini M. Annulus fibrosus (AF) differentiation of human bone marrow stem cells on biofabricated polycaprolactone scaffolds with oriented multi-lamellar architecture. 2019 SSB+RM (poster)

Vernengo A, Li Z, Grad S, Alini M, Eglin D. Annulus fibrosus differentiation of human bone marrow stem cells on polycaprolactone scaffolds with 3D printed oriented ply structure. 2019 ORS PSRS (oral)

Verrier S. Healing of large bone defects. 2019 GTRM (oral)

Wagner D, Kamer L, Noser H, Rommens PM. Bone mass along pedicle screw S1 depends on the correct pathway: The Superior Articular Process Screw is a valuable alternative. 2019 EFORT (poster)

Wagner D, Kamer L, Noser H, Rommens PM. Die Länge und Knochenmasse der Pedikelschraube in S1 in Abhängigkeit des Verlaufes. 2019 VSOU (oral)

Wahl P, Meier C, Dommann A, Neels A, Sprecher CM. Delaminierung der Hydroxylapatit-Beschichtung des Schaftes 14 Monate nach Implantation einer Hüft-Totalendoprothese. 2019 Endoprothetik (poster)

Wahl P, Meier C, Milz S, Dommann A, Neels A, Sprecher CM. Hydroxyapatite coating delamination – A case report 14 months after total hip arthroplasty. 2019 Meet the Expert (poster)

Wallimann A, Thompson K, Moriarty TF, Akdis CA, O'Mahony L. The influence of microbial-derived metabolites on bone health. 2019 WIRM (poster)

Wallimann A, Thompson K, Stanic B, O'Mahony L, Akdis CA, Moriarty TF. The influence of microbial-derived metabolites on bone health. 2019 eCM (poster)

Wallimann A, Thompson K, Stanic B, O'Mahony L, Akdis CA, Moriarty TF. The influence of microbial-derived metabolites on bone health. 2019 SGM – SSM (poster)

Wangler S, Peroglio M, Menzel U, Benneker LM, Haglund L, Sakai D, Alini M, Grad S. MSC homing facilitates IVD cell survival, proliferation and enhances the Tie2 positive IVD progenitor cell subpopulation. 2019 BioSpine (oral)

Wangler S, Peroglio M, Menzel U, Benneker L, Haglund L, Sakai D, Alini M, Grad S. MSC homing into intervertebral discs enhances the Tie2 positive progenitor cell population, prevents cell death and induces a proliferative response. 2019 ISSLS (poster)

Wenzel L, Ciric D, Mischler D, Qawasmi F, Gueorguiev B, Richards RG, Windolf M, Varga P. Biomechanical investigation of the effect of screw length on screw perforation in unstable 3-part osteoporotic proximal humerus fractures. 2019 DKOU (oral)

Yanev P, Zderic I, Pukalski Y, Enchev D, Rashkov M, Richards RG, Gueorguiev B, Baltov A. Biomechanical investigation of three plating techniques for displaced midshaft clavicle fracture fixation. 2019 ESBioMech (oral)

Yanev P, Pukalski Y, Zderic I, Rashkov M, Richards RG, Gueorguiev B, Enchev D, Baltov A. Is double plating of displaced midshaft clavicle fractures advantageous over single plate fixation? 2019 EORS (poster)

Yanev P, Zderic I, Pukalski Y, Rashkov M, Richards RG, Gueorguiev B, Enchev D, Baltov A. Two reconstruction plates provide superior stability of displaced midshaft clavicle fractures in comparison to single plating. 2019 BOTTA (oral)

Zderic I, Yanev P, Pukalski Y, Enchev D, Rashkov M, Richards RG, Gueorguiev B, Baltov A. Biomechanical evaluation of three different plating techniques for fixation of displaced midshaft clavicle fractures. 2019 DKOU (oral)

Ziadlou R, Grad S, Stoddart M, Wang X, Qin L, Barbero A, Martin I, Alini M. Investigation of Traditional Chinese Medicine (TCM) Bioactive Compounds Towards Treatment of Osteoarthritis. 2019 Day of Life Sciences (poster)

Ziadlou R, Grad S, Stoddart M, Wang X, Qin L, Barbero A, Martin I, Alini M. Regulation of inflammatory response by novel herbal small molecules in human osteoarthritic chondrocytes. 2019 TERMIS EU (oral)

14.8 Presentations (not in conference proceedings)





























- 27.05.2019 Richards Geoff: "TERMIS World President's Welcome", TERMIS EU Conference, Rhodes, Greece (Invited Speaker)
- 16.10.2019 Richards Geoff: "Infection: Waiting at the Door for Translation of TERM to the Patient", Tissue Engineering & Regenerative Medicine International Society (TERMIS) – Asia Pacific Chapter, Brisbane, Australia (TERMIS Global President)
- 03.04.2019 Alini Mauro: "MSC homing into degenerated intervertebral disc: A novel approach", 7th International Congress on Biotechnologies for Spinal Surgery, Rome, Italy (Invited Speaker)
- 05.04.2019 Alini Mauro: "MSC in Cartilage Regeneration", Gruppo Italiano Cellule Staminali, Annual Meeting, Genoa, Italy (Invited Speaker)
- 14.-15.04.2019 Alini Mauro: Workshop on Tissue Engineering and Regenerative Medicine, Department of Medical Biotechnology, Guilan University of Medical Science, Rasht, Iran (Invited Speaker)
- 18.05.2019 Alini Mauro: "Present and future biological approaches to human disc degeneration", Global Spine Congress, Toronto, Canada (Invited Speaker)
- 29.05.2019 Alini Mauro: "Hyaluronan hydrogel platform for musculoskeletal regeneration", TERMIS EU Conference, Rhodes, Greece (Invited Speaker)
- 20.06.2019 Alini Mauro: "Ian Macnab Lecture: 25 Years of Spine Basic Research: Nothing New on The Clinical Horizon?", Canadian Orthopaedic Research Society, Montreal, Canada (Invited Speaker)

- 28.09.2019 Alini Mauro: "Hyaluronan hydrogel platform for intervertebral disc regeneration", BioReMed 2019, Craiova, Romania (Invited Speaker)
- 08.-09.10.2019 Alini Mauro: "Hyaluronan hydrogel platform for musculoskeletal regeneration and more", 2nd International Workshop on Advanced Materials for Healthcare Applications, Madeira, Portugal (Invited Speaker)
- 19.-22.06.2019 Gueorguiev Boyko: "From wearables to smart implants: the AO Fracture Monitor to assess bone healing", Workshop EORS/ANZORS - digital mobility parameters from wearable devices - the future of orthopaedic outcome assessment? Why, how, and what do we know, 2nd International Combined Meeting of Orthopaedic Research Societies (ICORS), Montreal, Canada (Invited Speaker)
- 25.-27.09.2019 Gueorguiev Boyko: "AO translational research and development", International Conference of Metals, Ceramics and Composites (ICMCC), Varna, Bulgaria (Invited Speaker)
- 03.-06.10.2019 Gueorguiev Boyko: "AO preclinical research and development", 14th National Congress of the Bulgarian Orthopedic and Traumatology Association (BOTA) Varna, Bulgaria (Invited Speaker)
- 10.09.2019 Moriarty Fintan: "Local antibiotics delivery with hydrogels: from infection prevention to infection eradication in orthopedic trauma", 30th Annual Conference of the Society for Biomaterials, Dresden, Germany (Invited Speaker)
- 14.09.2019 Moriarty Fintan: Session Bacteriophage therapy, "Optimal delivery method", 38th Annual Meeting of the European Bone and Joint Infection Society, Antwerp, Belgium (Invited Speaker)
- 28.05.2019 Eglin David: "Fabrication of stimuli responsive hydrogel microenvironments for cell manipulation", TERMIS EU Conference, Rhodes, Greece (Invited Speaker)
- 13.09.2019 Eglin David: Session Innovation in treatment of biofilm related Infection, "Antibiotic delivery systems", 38th Annual Meeting of the European Bone and Joint Infection Society, Antwerp, Belgium (Invited Speaker)
- 03.04.2019 Grad Sibylle: "Organ culture models of disc degeneration", 7th International Congress on Biotechnologies for Spinal Surgery, Rome, Italy (Invited Speaker)
- 17.05.2019 Grad Sibylle: "Pre-clinical testing of anti-inflammatory compounds using a whole intervertebral disc organ culture model", Global Spine Congress, Toronto, Canada (Invited Speaker)
- 28.05.2019 Stoddart Martin: "Role of kinematic load on cell behavior", TERMIS EU Conference, Rhodes, Greece (Invited Speaker)
- 29.08.2019 D'Este Matteo: "3D Printing of a Hyaluronan Bioink With Double Gelation Mechanism for Independent Tuning of Shear-Thinning and Shape Fixation", 15th Congress on Stem Cell Biology and Technology, Royan International Twin Congress, Tehran, Iran (Invited Speaker)

- 30.08.2019 D'Este Matteo: "Towards Clinical Translation: Patents and Intellectual Property in Biomaterials Science", 15th Congress on Stem Cell Biology and Technology, Royan International Twin Congress, Tehran, Iran (Invited Speaker)
- 19.06.2019 Li Zhen: "Screening of Anti-Inflammatory and Regenerative Drug Therapy in a Bioreactor-Guided Intervertebral Disc Organ Culture Model", Workshop: Chinese ORS – Recent Advances in Intervertebral Disc Research, 2nd International Combined Meeting of Orthopaedic Research Societies (ICORS), Montreal, Canada (Invited Speaker)
- 12.-14.06.2019 Varga Peter: "Smart surgery – translational research and development at the AO Research Institute Davos", 27th Congress of the Hungarian Society of Surgical Research, Szeged, Hungary (Invited Speaker)
- 23.05.2019 Serra Tiziano: "Spatially orchestrated micro-vessels networks via acoustic waves cell patterning", Annual Meeting of the Swiss Society for Biomaterials and Regenerative Medicine SSB+RM, FNHW Campus, Muttensz, Switzerland (Invited Speaker)

60 YEARS | **AO Research Institute Davos**
 Advancing patient care through innovative
 orthopaedic research and development

Research fellowships 2009–2019

 Yves Achilli Pakistan	 Parisa Ahmad Pakistan	 Marc-Daniel Ahmed Germany	 Hayder Al-Raaid Emirates	 Giuseppe Alajmo Columbia	 Charlotte Arand Germany	 Stephan Artt Germany	 André Atroša Brazil	 Balazs Bago Hungary
 Aswix Beck Belgium	 Michael Blankens Canada	 Willemijn Boot The Netherlands	 Tim Buchholz Germany	 Marc-Antoine Burch Switzerland	 Lorenzo Calabro Australia	 Xu Chun China	 Carolina Constant Canada	 Nicolò Cosarelli Italy
 Xiangbin Cui China	 Jan Dancow Belgium	 Rafael Lara De Freitas Brazil	 InkaMiriam Drenning Germany	 Jie Du China	 Koen DeMaert The Netherlands	 Fabian Distenhofer Germany	 Balazs Erdélyi Hungary	 Julian Eggoldt Germany
 Christoph Erichson Germany	 Mariuska Ernst Switzerland	 Igor Escalante Venezuela	 Julian Fischer Germany	 Marlon Fischer Germany	 James Fletcher United Kingdom	 Andrew Foster Australia	 Linda Freitag Germany	 Marc A. Fritzsche Germany
 Ashay Gufekumbho India	 Dominik Gebweiler Germany	 Marilina Glöck Germany	 Michael Götzon Austria	 Maria Gomez Colombia	 Niklas Grönewald Germany	 Leonard Grünwald Germany	 Pasha Gudoshvili Georgia	 Christian Günther Germany
 Simon Hackl Germany	 Sonja Häckel Germany	 Mariya Hachinskikova Bulgaria	 Jennifer Hagen USA	 Kristin Handrick Germany	 Tobias Heßler Germany	 Ming-Hsueh Ho Taiwan	 Stoyan Ivanov Bulgaria	 Jagoda Jaborec Poland
 Amir Kamali Iran	 Aron Kashanian Germany	 Qianxiang Lang Germany	 Mark Leuz Germany	 Markus Lill Austria	 Meritz Ledde Germany	 Claudia Leibel Germany	 Markus Lohl Germany	 Cameron Lutten Australia
 Jiaxuan Ma China	 Andy Mahoney USA	 Willem-Jan Meesters The Netherlands	 Alexander Mitzroy Germany	 Eduardo Moran Venezuela	 Mario Morgenshtern Germany	 Andreas Naros Germany	 Verena Neumann Germany	 Tomas Nicolino Argentina
 Johanna Nilsson Sweden	 Bronisław Nowicki Poland	 Walter Ocampo Costa Rica	 Jolien Orsma Belgium	 Yaeli Panagiotopoulos Greece	 Preslav Penev Bulgaria	 Sarah Peters USA	 Stoyan Pothov Bulgaria	 Marius Pothov Germany
 Tatjana Privi Germany	 Albrecht Popp Germany	 Virginia Post Germany	 Philipp Pesketeur Germany	 Jan Pitzler Germany	 Bruna Pugliese USA	 Yavor Pukalski Bulgaria	 Faraz Qassemi USA	 Tobias Rauber Germany
 Valentinia Rühl Germany	 Justine Roberts USA	 René Rothweiler Germany	 Lyubomir Rusinov Bulgaria	 Julia Kalvarnikova Columbia	 Elifburak Kamara Greece	 Guillermo Sanchez Guatemala	 Jana Kschieder Germany	 Florian Schneider Germany
 Nina Schmitz Germany	 Kerstin Schneider Germany	 Mamud Schmeider Germany	 Clemens Schopper Austria	 Josh Schroeder Israel	 Ahmad F. Saif Eldin Egypt	 An Szymon Belgium	 Guilherme Severa Gomes Brazil	 Claas Soyboth Brazil
 Rikun Aikhanhan Bhutan Japan	 Eamon Sheehy Ireland	 Yanyuqi Shinzaki Japan	 Juan Diego Silva Columbia	 Angharad Simpson United Kingdom	 Theodora Simonow Germany	 Judith Sittardacher Germany	 Aleksandar Stojanov Bulgaria	 Valentina Stunger Germany
 Alkateris Stylianaki Greece	 Igor Terzijas Latvia	 Dimitar Todorov Bulgaria	 Miguel Triana Colombia	 Dostel Vlachov Bulgaria	 Alejandro Vallejo Colombia	 Editra Varga Hungary	 Viktor Vargha Hungary	 Ulf Vukobrat Germany
 Kalan Vidin Brazil	 Christian von Gemling Switzerland	 Jan Voss Germany	 Daniel Wagner Germany	 Ning Wang China	 Robbe van Waeghe Switzerland	 Ferdinand Wessmann Germany	 Lisa Wiesend Germany	 Gaston Camille Wilmotte Argentina
 Sandra Wissing Germany	 Charlotte Wittmann Germany	 Chen Yan China	 Parvan Yavor Bulgaria	 Shinobu Yawashi Japan	 Yichi Xia China	 Philipp Zerbe Switzerland	 Ying Zhang China	 Zhiyi Zhou China